

## OPERATING MANUAL

### World K Series Terminal Box Type Induction Motors and Reversible Motors



#### Before using the motor

##### Introduction

Only qualified personnel should work with the product. Use the product correctly after thoroughly reading the section "Safety precautions". Should you require the inspection or repair of internal parts, contact the Oriental Motor office where you purchased the product. The product described in this manual has been designed and manufactured for use in general industrial machinery, and must not be used for any other purpose. Oriental Motor Co., Ltd. is not responsible for any damage caused through failure to observe this warning.

##### Regulations and standards

Check on the Oriental Motor Website for the regulations and standards.

##### UL Standards, CSA Standards

This product is recognized by UL under the UL and CSA Standards.

##### CE Marking

This product is affixed the CE Marking under the Low Voltage Directive.

##### Low Voltage Directive

Applications for standard

EN 60034-1, EN 60034-5, EN 60664-1, EN 62368-1

Installation conditions

Overvoltage category II, Pollution degree 2, Class I equipment (For EN standards) When the machinery to which the motor is mounted requires overvoltage category III and pollution degree 3 specifications, install the motor in a cabinet that comply with IP54 and connect to power supply via an isolation transformer.

##### Motor temperature rise tests

Temperature rise tests required by the standards are conducted for the round shaft type motors are conducted in a state of attaching a heat radiation plate. The size, thickness and material of the heat radiation plates are as follows.

Motor name	Size [mm (in.)]	Thickness [mm (in.)]	Material
2IK, 2RK	115 × 115 (4.53 × 4.53)	5 (0.20)	Aluminium alloy
5IK, 5RK	200 × 200 (7.87 × 7.87)		

#### Safety precautions

The precautions described below are intended to prevent danger or injury to the user and other personnel through safe, correct use of the product. Use the product only after carefully reading and fully understanding these instructions.

<b>WARNING</b>	Handling the product without observing the instructions that accompany a "WARNING" symbol may result in serious injury or death.
<b>CAUTION</b>	Handling the product without observing the instructions that accompany a "CAUTION" symbol may result in injury or property damage.
<b>Note</b>	The items under this heading contain important handling instructions that the user should observe to ensure safe use of the product.

#### **WARNING**

- Do not use the product in explosive or corrosive environments, in the presence of flammable gases, locations subjected to splashing water, or near combustibles. Doing so may result in fire, electric shock or injury.
- Assign qualified personnel the task of installing, wiring, operating/ controlling, inspecting and troubleshooting the product. Failure to do so may result in fire, electric shock or injury.
- Do not transport, install the product, perform connections or inspections when the power is on. Always turn the power off before carrying out these operations. Failure to do so may result in electric shock.

Thank you for purchasing an Oriental Motor product.

This Operating Manual describes product handling procedures and safety precautions.

- Please read it thoroughly to ensure safe operation.
- Always keep the manual where it is readily available.

- Turn off the power in the event the overheat protection device (thermal protector) is triggered. Failure to do so may result in injury or damage to equipment, since the motor will start abruptly when the overheat protection device (thermal protector) is automatically reset.
- The motor is Class I equipment. Install the motor so as to avoid contact with hands, or ground it to prevent the risk of electric shock. If the motor has a protective ground terminal, be sure to connect the terminal to the ground.
- Install the motor in an enclosure in order to prevent electric shock or injury.
- Keep the input-power voltage within the specification to avoid fire and electric shock.
- Connect the cables securely according to the wiring diagram in order to prevent fire and electric shock.
- Do not forcibly bend, pull or pinch the lead wires. Doing so may result in fire and electric shock.
- Be sure to insulate the connection terminal of the capacitor. Failure to do so may result in electric shock.
- Turn off the power in the event of a power failure, or the motor will suddenly start when the power is restored and may cause injury or damage to equipment.
- Do not touch the connection terminal of the capacitor immediately after the power is turned off (for a period of 30 seconds). The residual voltage may cause electric shock.
- Do not disassemble or modify the motor. This may cause electric shock or injury.

#### **CAUTION**

- Do not use the motor beyond its specifications, or electric shock, injury or damage to equipment may result.
- Do not touch the motor during operation or immediately after stopping. The surface is hot and may cause a burn.
- Do not hold the motor output shaft. This may cause injury.
- Keep the area around the motor free of combustible materials in order to prevent fire or a burn.
- To prevent the risk of damage to equipment, leave nothing around the motor that would obstruct ventilation.
- To prevent bodily injury, do not touch the rotating parts (output shaft, cooling fan) of the motor during operation.
- When an abnormality is noted, turn off the power immediately, or fire, electric shock or injury may occur.
- The motor's surface temperature may exceed 70 °C, even under normal operating conditions. If a motor is accessible during operation, post the warning label shown in the figure in a conspicuous position to prevent the risk of burns.
- Dispose the product correctly in accordance with laws and regulations, or instructions of local governments.



Warning label

#### Preparation

##### Checking the product

Upon opening the package, verify that the items listed below are included. Report any missing or damaged items to the branch or sales office from which you purchased the product.

- Motor ..... 1 unit
- Capacitor ..... 1 piece (only for single-phase motor)
- Capacitor cap. .... 1 piece (only for single-phase motor)
- Operating manual (this manual) ..... 1 copy

## ■ Checking the model name

Check the model number against the number indicated on the product.

### ● Induction motors

Model	Motor model	Capacitor model
21K6GN-AWTJ *	21K6GN-AWT *	CH35FAUL2
21K6GN-AWTU *		CH25FAUL2
21K6GN-CWTJ *	21K6GN-CWT *	CH08BFAUL
21K6GN-CWTE *		CH06BFAUL
51K60GU-AWTJ	51K60GU-AWT	CH200CFAUL2
51K60GU-AWTU		CH180CFAUL
51K60GU-CWTJ	51K60GU-CWT	CH50BFAUL
51K60GU-CWTE		CH40BFAUL
51K90GU-AWTJ	51K90GU-AWT	CH280CFAUL2
51K90GU-AWTU		CH200CFAUL2
51K90GU-CWTJ	51K90GU-CWT	CH70BFAUL
51K90GU-CWTE		CH60BFAUL
21K6GN-SWT	21K6GN-SWT	-
51K60GU-SWT	51K60GU-SWT	-
51K90GU-SWT	51K90GU-SWT	-

### ● Reversible motors

Model	Motor model	Capacitor model
2RK6GN-AWTJ *	2RK6GN-AWT *	CH45FAUL2
2RK6GN-AWTU *		CH35FAUL2
2RK6GN-CWTJ *	2RK6GN-CWT *	CH10BFAUL
2RK6GN-CWTE *		CH08BFAUL
5RK60GU-AWTJ	5RK60GU-AWT	CH250CFAUL2
5RK60GU-AWTU		CH200CFAUL2
5RK60GU-CWTJ	5RK60GU-CWT	CH60BFAUL
5RK60GU-CWTE		CH50BFAUL
5RK90GU-AWTJ	5RK90GU-AWT	CH350CFAUL
5RK90GU-AWTU		CH300CFAUL2
5RK90GU-CWTJ	5RK90GU-CWT	CH80BFAUL
5RK90GU-CWTE		CH70BFAUL

The list above shows pinion shaft motors.

\* For the round shaft motor, "GN" in the model and motor model are replaced by "A."

## Installation

### ■ Location for installation

The motor is designed and manufactured for installation in equipment. Install it in a well-ventilated location that provides easy access for inspection. The location must also satisfy the following conditions:

- Inside an enclosure that is installed indoors (provide vent holes)
- Operating ambient temperature
  - 10 to +40 °C (+14 to +104 °F) (non-freezing)
  - 10 to +50 °C (+14 to +122 °F) for 100/200 V (non-freezing)
- Operating ambient humidity 85%, maximum (non-condensing)
- Area that is free of explosive atmosphere or toxic gas (such as sulfuric gas) or liquid
- Area not exposed to direct sun
- Area free of excessive amount of dust, iron particles or the like
- Area not subject to splashing water (rains, water droplets), oil (oil droplets) or other liquids
- Area free of excessive salt
- Area not subject to continuous vibration or excessive shocks
- Area free of excessive electromagnetic noise (from welders, power machinery, etc.)
- Area free of radioactive materials, magnetic fields or vacuum
- 1000 m or less above sea level

### ■ How to install the motor

#### ● Round shaft type (6 W)

Drill holes on the mounting plate and fix the motor on the plate using screws, nuts, and washers (not supplied). Be careful there is no gap between the motor installation surface and the bracket.

Nominal diameter of screw: M4  
Tightening torque: 2.0 N·m  
(17.7 lb-in)

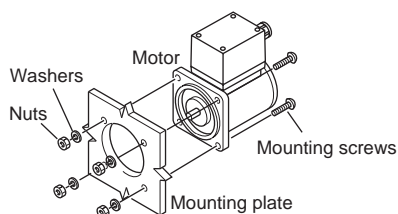

### Note

Do not insert the motor into the mounting hole at an angle or force it in, as this may scratch the flange pilot section and damage the motor.

### ● Pinion shaft type

Drill holes on the mounting plate and fix the motor and gearhead on the plate using screws supplied with the gearhead. Be careful there is no gap between the motor flange and the gearhead.

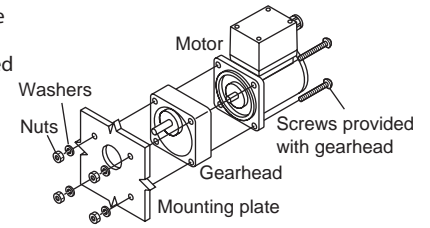

### Note

Use the gearhead with pinion shaft which is identical with one of motor.

### ● Motor with cooling fan

When installing a motor with cooling fan onto a device, leave 10 mm (0.39 in.) or more behind the fan cover or open a ventilation hole so that the cooling inlet on the back of the motor cover is not blocked.

### ■ Mounting the capacitor (Only for single-phase motors)

Before mounting the provided capacitor, check that the capacitor's capacitance matches that stated on the motor's name plate. Mount the capacitor securely by using M4 screws (not provided).

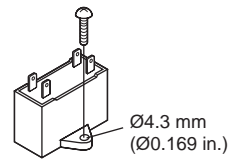

### Note

- Do not let the screw fastening torque exceed 1 N·m (8.8 lb-in) to prevent damage to the mounting foot.
- Mount capacitor at least 10 cm (3.94 in.) away from the motor. If it is located closer, the life of the capacitor will be shortened.

## Connection and operation

Insulate all the wire connections, such as the connection between the motor and the capacitor connection. Use the supplied capacitor cap to insulate the capacitor terminal connection.

### Note

- Insulation class of this motor is B.
  - Make sure that the motor case temperature does not exceed 90 °C (194 °F) during operation of the motor. Operation exceeding case temperature 90 °C (194 °F) may significantly deteriorate the coils and ball bearings of the motor and shorten the motor's life span. Motor case temperature can be measured by fixing a thermometer on the motor surface. It can also be measured using thermo tape or a thermocouple.
- To change rotation direction of the single-phase induction motor, wait until the motor completely stops. Otherwise its direction may not change or may take much time to change.
- Single-phase motors use a capacitor and keep it connected even after rotation of the motor has started.

### ■ Connection method to a terminal box

#### ● 6 W types

Terminal cover screws

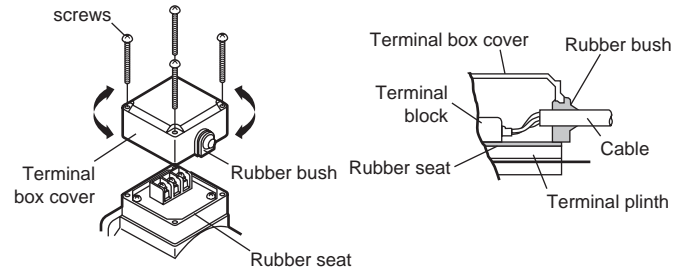

- For wiring, be sure to use cable that meets the following specifications.
  - Cable: Diameter is Ø6.8 to 8.6 mm (Ø0.27 to 0.33 in.)
- When sealing the terminal cover, ensure that no scraps or particles get caught between the contact surfaces.
- In order to maintain a tight seal around the terminal box, the rubber seat use between terminal box cover and terminal plinth. Also this terminal box is constructed to hold a rubber seat. If this rubber comes out of the box, please seat it correctly on the box.

- Also refer to the tightening torque table to determine the appropriate tightening torque to use when fastening the terminal box cover and terminal block.

Terminal box cover	0.3 N·m (42 oz-in.)
Motor connecting terminals	0.8 to 1.0 N·m (113 to 142 oz-in.)

**Note**  
Use a cable of an appropriate diameter.

### Appropriate terminal strip

Ring terminal with insulation

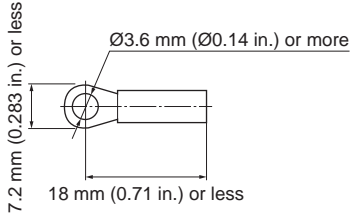

Fork terminal with insulation

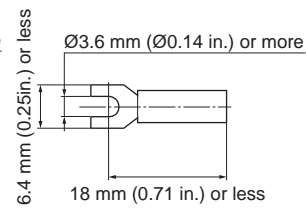

- Cable entry is possible at any of the four sides of the terminal box. Undo the screws which fixed terminal box to the motor case, position the terminal box so that the outlet faces in the desired direction and re fasten the screws.

### 60 to 90 W types

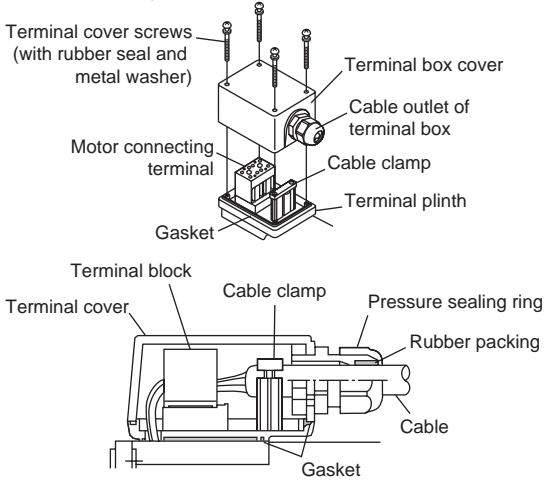

- To ensure safety, ground the motor using the ⊕ inside the terminal box. On the three phase round shaft motor type, refer to the following specification.

Applicable crimp terminal:  
Insulated round crimp terminal  
Terminal screw size: M4  
Tightening torque:  
1.0 to 1.3 N·m (8.8 to 11.5 lb-in)  
Applicable minimum lead wire size:  
AWG18 (0.75 mm<sup>2</sup>) or more

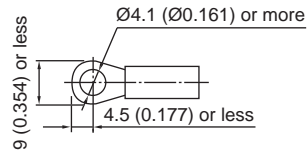

- For wiring, be sure to use cable that meets the following specifications.  
Cable: Diameter is 06.0 to 12.0 mm (0.236 to 0.472 in.)  
Lead Wires: Thickness is AWG24 to 12 (0.2 to 3.5 mm<sup>2</sup>)  
Length of strip is 8 mm (0.31 in.)
- When sealing the terminal cover, ensure that no scraps or particles get caught between the contact surfaces.
- The terminal cover screws are specifically designed for mounting the terminal cover. They are provided with a rubber seal and metal washer that keep the terminal box splashproof. In order to maintain a tight seal around the terminal box, use only the provided screws. Also, this terminal box is constructed to hold a gasket. If this gasket comes out of the box, please reseal it correctly on the box. Also refer to the tightening torque table to determine the appropriate tightening torque to use when fastening the terminal box cover and cable outlet.

### Tightening torque

Terminal Box Cover	0.3 to 0.4 N·m (42 to 56 oz-in.)
Cable Outlet of Terminal Box Cover	2.5 to 3.8 N·m (350 to 530 oz-in.)
Cable Clamp	0.2 to 0.3 N·m (28 to 42 oz-in.)
Motor Connecting Terminals	0.5 to 0.8 N·m (71 to 113 oz-in.)

**Note**

- To make shielding function fully effective, use a cable of an appropriate diameter.
- Securely affix the cable exposed outside the motor so that it does not receive stress.

## Wiring diagram

Connect the motor according to the figure.

Directions of rotation in the diagram are shown as viewed from the flange surface of the motor. "CW" indicates clockwise and "CCW" counterclockwise.

### 6 W type

#### Single-phase motors

Induction motors

The connection method will vary, depending on the direction.

Clockwise

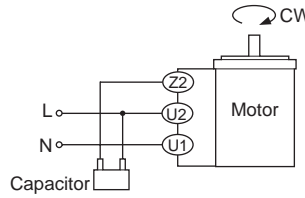

Counterclockwise

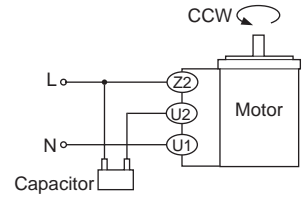

Reversible motors

To rotate the motor in a clockwise (CW) direction, flip switch to CW.  
To rotate it in a counterclockwise (CCW) direction, flip switch to CCW.

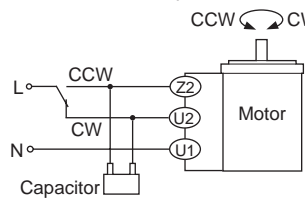

Layout of terminals

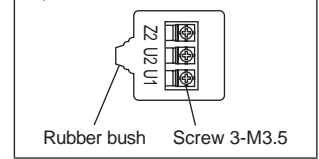

#### Three-phase motors

To change the direction of rotation, change any two connections between U, V and W.

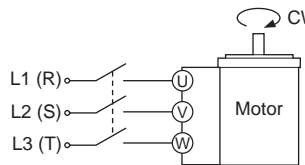

Layout of terminals

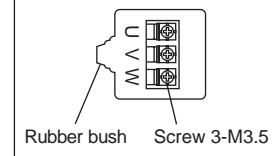

### 60 to 90 W type

#### Single-phase motors

Induction motors

The connection method will vary, depending on the direction.

Clockwise

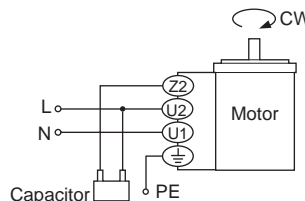

Counterclockwise

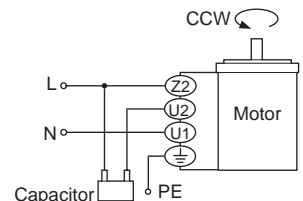

Reversible motors

To rotate the motor in a clockwise (CW) direction, flip switch to CW.  
To rotate it in a counterclockwise (CCW) direction, flip switch to CCW.

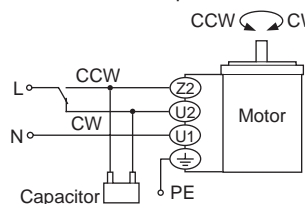

Layout of terminals

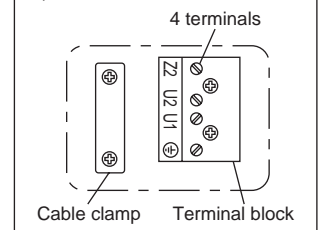

### ● Three-phase motors

To change the direction of rotation, change any two connections between U, V and W.

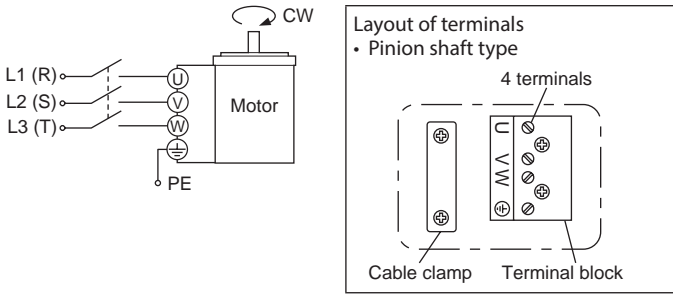

### ■ Capacitor connection (for only single-phase motors)

The capacitor internal wiring as follows:  
Capacitor terminals are internally electrically connection in twos; A-B and C-D for easy connection.  
For easy to install terminals use 187 series FASTON terminals (TE Connectivity).

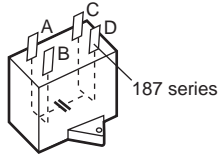

**Note**  
For lead wire connection, use one lead wire for each individual terminal.

### ● Capacitor cap

- ① Pass the lead wires through the capacitor cap as shown in the figure.
- ② Connect the lead wires to the terminals or use terminal ends.
- ③ Cover the capacitor with the capacitor cover.

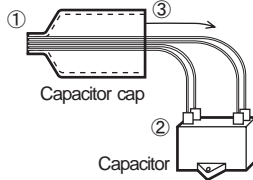

### Time rating

#### ● Induction motors

Induction motors have a continuous rating.

#### ● Reversible motors

Reversible motors have a 30 minutes rating. "30 min" is indicated on the nameplate.

### Locked rotor burnout protection

This motor is equipped with one of two methods to prevent burning the motor as a result of abnormal heating.

#### ■ Thermal protection

"TP" is stamped on the motor nameplate. The motor has an "auto reset" type thermal protector built into its motor coil. When the motor reaches a predetermined temperature, the internal thermal protector is activated and the motor is stopped.

Always turn the power off before performing inspections.

Thermal protector activation range:

Power is turned off at 130±5 °C (266±9 °F)

Power is turned back on at 85±20°C (185±36 °F)

#### ■ Impedance protection

"ZP" is stamped on the motor nameplate. The motor has higher coil impedance. When the motor goes into locked rotor condition due to a malfunction, coil impedance rises, suppressing input power to the motor and protecting the motor coil from burnout.

## Troubleshooting

When the motor cannot be operated correctly, refer to the contents provided in this section and take appropriate action. If the problem persists, contact your nearest office.

Phenomena	Check items
Motor does not rotate or rotates slowly.	<ul style="list-style-type: none"> <li>• Is supplied voltage appropriate?</li> <li>• Is the power source securely connected?</li> <li>• For a single-phase motor is the capacitor properly connected?</li> <li>• Is there a faulty contact on terminal blocks or crimped terminals if the cable is extended?</li> <li>• Is the load on the motor too much?</li> </ul>
Motor sometimes rotates and stops.	<ul style="list-style-type: none"> <li>• Is the power source securely connected?</li> <li>• For a single-phase motor is the capacitor properly connected?</li> <li>• Is there a faulty contact on terminal blocks or crimped terminals if the cable is extended?</li> </ul>
Motor rotates in reverse direction.	<ul style="list-style-type: none"> <li>• If the motor connected differently than the "wiring diagram" shown in this manual. Check wiring by referring to the "wiring diagram".</li> <li>• For a single-phase motor is the capacitor properly connected?</li> <li>• In some gearheads, rotation direction of the gearhead output shaft may differ from rotation direction of the motor. See the operating manual for the gearhead.</li> <li>• Is your understanding of rotation direction different than the manual description? In this manual rotation direction of the motor is defined as viewed at the motor from shaft side.</li> </ul>
Motor temperature abnormally high [Motor case temperature exceeds 90 °C (194 °F)]	<ul style="list-style-type: none"> <li>• Is appropriate voltage applied to the motor?</li> <li>• For a single-phase motor is the capacitor properly connected?</li> <li>• Does ambient temperature exceed the specified range?</li> </ul>
Noisy operation	<ul style="list-style-type: none"> <li>• Are the motor and gearhead appropriately coupled? See the operating manual for the gearhead.</li> <li>• Is the coupled gearhead the same pinion type as the motor shaft?</li> </ul>

- Unauthorized reproduction or copying of all or part of this manual is prohibited.
- Oriental Motor shall not be liable whatsoever for any problems relating to industrial property rights arising from use of any information, circuit, equipment or device provided or referenced in this manual.
- Characteristics, specifications and dimensions are subject to change without notice.
- While we make every effort to offer accurate information in the manual, we welcome your input. Should you find unclear descriptions, errors or omissions, please contact the nearest office.
- **Orientalmotor** is a registered trademark or trademark of Oriental Motor Co., Ltd., in Japan and other countries.

© Copyright ORIENTAL MOTOR CO., LTD. 2006

Published in November 2022

- Please contact your nearest Oriental Motor office for further information.

ORIENTAL MOTOR U.S.A. CORP.  
Technical Support Tel:800-468-3982  
8:30am EST to 5:00pm PST (M-F)  
www.orientalmotor.com

ORIENTAL MOTOR (EUROPA) GmbH  
Schiesstraße 44, 40549 Düsseldorf, Germany  
Technical Support Tel:00 800/22 55 66 22  
www.orientalmotor.de

ORIENTAL MOTOR (UK) LTD.  
Unit 5 Faraday Office Park, Rankine Road,  
Basingstoke, Hampshire RG24 8QB UK  
Tel:+44-1256347090  
www.oriental-motor.co.uk

ORIENTAL MOTOR (FRANCE) SARL  
Tel:+33-1 47 86 97 50  
www.orientalmotor.fr

ORIENTAL MOTOR ITALIA s.r.l.  
Tel:+39-02-93906347  
www.orientalmotor.it

ORIENTAL MOTOR CO., LTD.  
4-8-1 Higashiueno, Taito-ku, Tokyo 110-8536  
Japan  
Tel:+81-3-6744-0361  
www.orientalmotor.co.jp

ORIENTAL MOTOR ASIA PACIFIC PTE. LTD.  
Singapore  
Tel:1800-842-0280  
www.orientalmotor.com.sg

ORIENTAL MOTOR (MALAYSIA) SDN. BHD.  
Tel:1800-806-161  
www.orientalmotor.com.my

ORIENTAL MOTOR (THAILAND) CO., LTD.  
Tel:1800-888-881  
www.orientalmotor.co.th

ORIENTAL MOTOR (INDIA) PVT. LTD.  
Tel:1800-120-1995 (For English)  
1800-121-4149 (For Hindi)  
www.orientalmotor.co.in

TAIWAN ORIENTAL MOTOR CO., LTD.  
Tel:0800-060708  
www.orientalmotor.com.tw

SHANGHAI ORIENTAL MOTOR CO., LTD.  
Tel:400-820-6516  
www.orientalmotor.com.cn

INA ORIENTAL MOTOR CO., LTD.  
Korea  
Tel:080-777-2042  
www.inaom.co.kr