

World K Series Electromagnetic Brake Motors OPERATING MANUAL



Thank you for purchasing ORIENTAL MOTOR products. Please read this operating manual thoroughly before installing and operating the motor, and always keep the manual where it is readily accessible.

<Table of contents>

1. Precautions.....	Page 1	5. Connection and Operation.....	Page 4
2. Checking the package contents	Page 1	6. Time Rating	Page 5
3. Regulations and standards.....	Page 2	7. Locked rotor burnout protection.....	Page 5
4. Installation	Page 2	8. Troubleshooting	Page 6

1. Precautions

1.1 Precautions for Installation

- Do not use in a place where there is flammable gas and/or corrosive gas.
- When installing the motor into your equipment, ensure that the motor lead wires are fixed and do not move. In addition, do not apply any pressure to these lead wires.
- The motor is Class I equipment. Install the motor so as to avoid contact with hands, or ground it to prevent the risk of electric shock.
- The motor housing must be mounted with a screw and spring washer to the ground point of the equipment.
- Installation must be performed by a qualified installer.

1.2 Precautions for Operation

- The Motor case temperature can exceed 70°C (depending on operation conditions). In case motor is accessible during operation, please attach the following warning label so that it is clearly visible.
- Always turn off the power to the motor before conducting checks or performing work on the motor. Thermally protected motors will restart automatically when motor temperature falls below a certain level.
- Do not use the electromagnetic brake of the motor as a safety brake. In the event the overheat protection device (thermal protector) is triggered, the load will not be held in position. A safety device should be provided separately.



Warning label

2. Checking the package contents

2.1 Checking the contents

Make sure that you have received all of the items listed below.

If an accessory is missing or damaged, contact the nearest ORIENTAL MOTOR office.

- Motor..... 1
- Capacitor..... 1 (for only single-phase motors)
- Capacitor cap..... 1 (for only single-phase motors)
- This operating manual 1

2.2 Checking the product name and motor-capacitor combination

This product comes in a combined set consisting of a motor and a capacitor. When the product first arrives, check the name plates to confirm that you have received the correct motor and capacitor combination.

■ 100V/110V/115V type

Model	Motor model	Capacitor Model
5RK60GU-AWMJ	5RK60GU-AWM	CH250CFAUL2
5RK60GU-AWMU		CH200CFAUL2
5RK90GU-AWMJ	5RK90GU-AWM	CH350CFAUL
5RK90GU-AWMU		CH300CFAUL2

■ 200V/220V/230V type

Model	Motor model	Capacitor Model
5RK60GU-CWMJ	5RK60GU-CWM	CH60BFAUL
5RK60GU-CWME		CH50BFAUL
5RK90GU-CWMJ	5RK90GU-CWM	CH80BFAUL
5RK90GU-CWME		CH70BFAUL
5IK60GU-SWM	5IK60GU-SWM	-
5IK90GU-SWM	5IK90GU-SWM	-

3. Regulations and standards

Check on the Oriental Motor Website for the regulations and standards.

■ UL Standards, CSA Standards

This product is recognized by UL under the UL and CSA Standards.

■ CE Marking

This product is affixed the CE Marking under the Low Voltage Directive.

• Low Voltage Directive

Applications standards

EN60034-1, EN60034-5, EN60664-1, EN 62368-1

Installation Conditions

Overvoltage category II , Pollution degree 2, Class I equipment (For EN standards)

When the machinery to which the motor is mounted requires overvoltage III and pollution degree 3 specifications, install the motor in a cabinet that comply with IP54 and connect to power supply via an isolation transformer.

■ Motor temperature rise tests

Temperature rise tests required by the standards are conducted in a state of attaching a heat radiation plate.

The size, thickness and material of the heat radiation plates are as follows.

[Size] 200×200 mm (7.87×7.87 in.) [Thickness] 5 mm (0.20 in.) [Material] Aluminum alloy

4. Installation

Installation conditions

Install the motor and capacitor in a location that meets the following conditions. Using the motor and capacitor in a location that does not satisfy these conditions could damage it.

- Indoors (this product is designed and manufactured to be installed within another device)
- Ambient temperature: -10°C(14°F) ~ +40°C(104°F) (avoid freezing)
(-10°C(14°F) ~+50°C(122°F) for 100V/200V)
- Ambient humidity: 85% max. (avoid condensation)
- Not exposed to explosive, flammable, or corrosive gas
- Not exposed to direct sunlight
- Not exposed to dust
- Not exposed to water or oil
- A place where heat can escape easily
- Not exposed to continuous vibration or excessive impact
- 1,000 meters or less above sea level
- Overvoltage category II , Pollution degree 2, Class I equipment (For EN standards)
When the machinery to which the motor is mounted requires overvoltage category III and pollution degree 3 specifications, install the motor in a cabinet that comply with IP54 and connect to power supply via an isolation transformer.

4.1 Mounting the motor

1) Pinion shaft motor

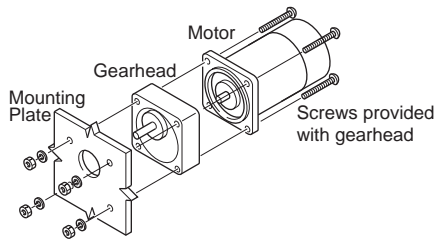

Drill holes in the mounting plate that match the screws and the motor's dimensions.

Attach the motor and gearhead using the screws supplied with the gearhead (gearhead sold separately).

Fasten the screws supplied with the gearhead to the mounting plate. Attach so that no gaps are left between the motor flange surface and the gearhead pilot section end surface.

Refer to the gearhead operation manual for further details concerning mounting (gearhead sold separately).

Note: Use the gearhead of the same type of pinion shaft as the motor.

2) Motor with cooling fan

When mounting a motor with a cooling fan onto a device, open a ventilation hole or leave 10 millimeters (0.4 inches) or more behind the fan cover so that the cooling inlet on the back of the motor cover is not blocked.

4.2 Mounting the capacitor (For only single-phase motors)

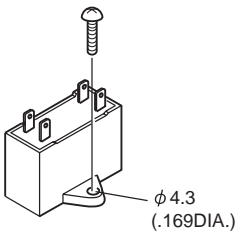

Before mounting the provided capacitor, check that the capacitor's capacitance matches that stated on the motor's name plate.

Use M4 screws to mount the capacitor (screws not provided).

Note -Do not let the screw fastening torque exceed 1 N·m (10 kgfcm) to prevent damage to the mounting feet.
-Mount capacitor at least 10 cm (3.94 inches) away from the motor. If it is located closer, the life of the capacitor will be shortened.

* Dimensions in millimeters (inches).

4.3 Changing Direction of the Cable Outlet

The direction of the cable outlet is the output shaft side of the motor when shipping.

The direction of outlet can be changed by 180° if desired.

Change the direction of the cable outlet according to following steps.

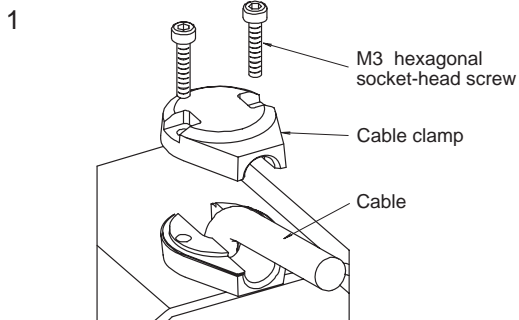

1. Remove screws and upper unit of cable clamp.
Put the cable toward the opposite direction.

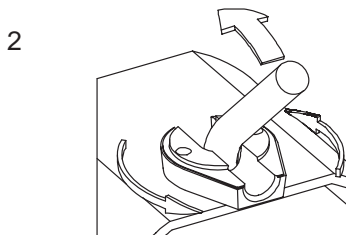

2. Turn the cable clamp to change the direction of cable outlet.

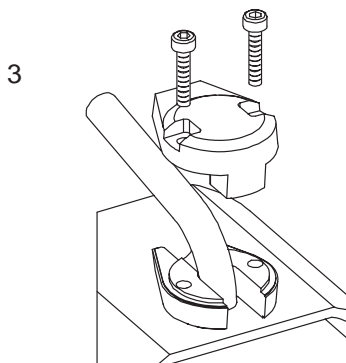

3. Refasten upper unit of cable clamp with screws.

Note: Keep the tightening torque within the limits shown below to prevent the cable from coming loose or to damage caused by excessive tightening torque.

Screw tightening torque 0.5 N·m (5 kgfcm) ~ 0.7 N·m (7 kgfcm)

5. Connection and Operation

5.1 Connection

- Connect the motor according to the "wiring diagram" shown below.
- Insulate all the wire connections, such as the connection between the motor and the capacitor connection.
Capacitor caps are available to insulate capacitor connection.

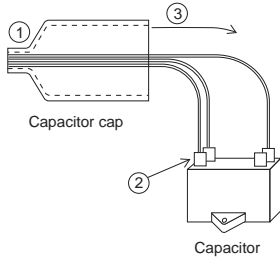

Capacitor caps

1. Pass the lead wires through the capacitor cover as shown in the figure.
2. Connect the lead wires to the terminals or use terminal ends.
3. Cap the capacitor with the capacitor cover.

■ Wiring diagram

The motor rotates in a clockwise (CW) and counterclockwise (CCW) direction (viewing the motor from the side with the output shaft).

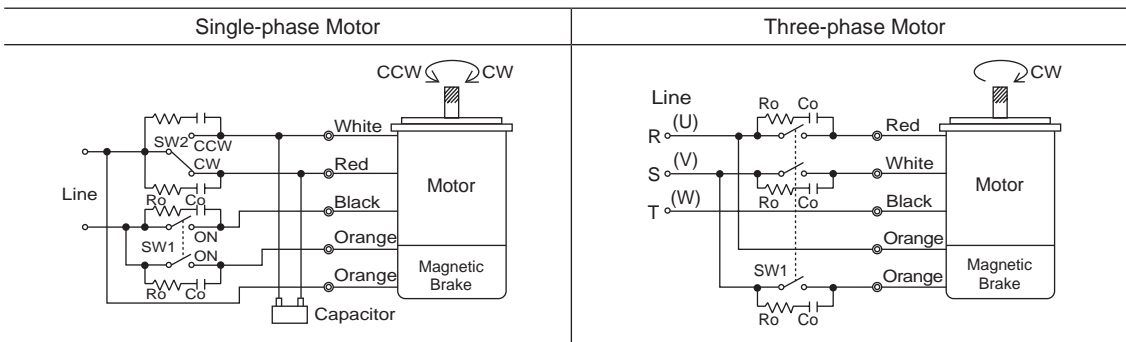

SW1 emits sparks when turned on and off. In order to protect the relay contacts, CR circuit (—|—) must be connected.

$R_o=5\sim 200\Omega$

$C_o=0.1\sim 0.2\mu F$ 250WV

Option of the ORIENTAL MOTOR's surge absorber is available.

Optional product name **EPCR1201-2** (sold separately)

No. of Switch	Specification			Note
	Single-phase 100V/110V/115V	Single-phase 200V/220V/230V	Three-phase 200V/220V/230V	
SW1	AC125V 5A or more Inductive load	AC250V 5A or more Inductive load	AC250V 5A or more Inductive load	Switched Simultaneously
SW2			-	-

Note: When removing the sheath of the cable, be careful not to damage the inside lead wire.

■ Capacitor Connection (For only single-phase motors)

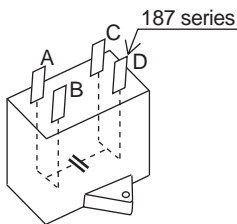

The capacitor internal wiring is as follows:

Capacitor terminals are internally electrically connected in twos; A-B and C-D for easy connection.

For easy to install terminals use 187 series FASTON Terminals (TE Connectivity).

For lead wire connection, use one lead wire for each individual terminal.

■ Simplified Connection

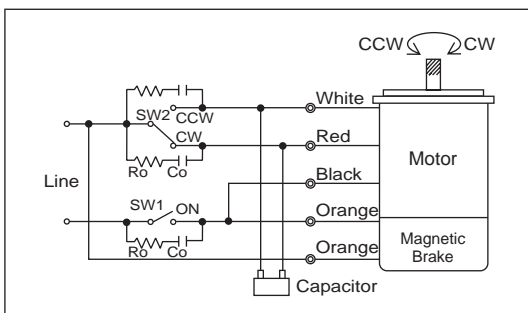

Note: Wiring cannot be simplified for vertical drive applications or three-phase motors.

Connection can be simplified by using the connecting diagrams shown below when changing the switch RUN/STOP of the motor and the electromagnetic brake by one switch. Using the connection shown below, however, results in a 50msec. increase in braking time over that of the basic connection with a corresponding increase in overrun. The reason for this is that an electromagnetic energy of motor electromagnetic brake, so that the electromagnetic continues to operate for about 50msec. even though the switch SW1 has been turned off. The brake thus takes longer to engage.

5.2 Operation

- Note:** -Make sure that the motor case temperature does not exceed 90°C (194°F) during motor operation. Operating the motor above 90°C (194°F) will shorten the life of the coil and the ball bearings. Motor case temperature can be measured by fastening a thermometer to the motor's surface, or with thermo-tape. Thermal Class: 130 (B)
- Be sure to use the capacitor that comes standard with your motor.
Keep the capacitor connected all the time even after the motor has been started.

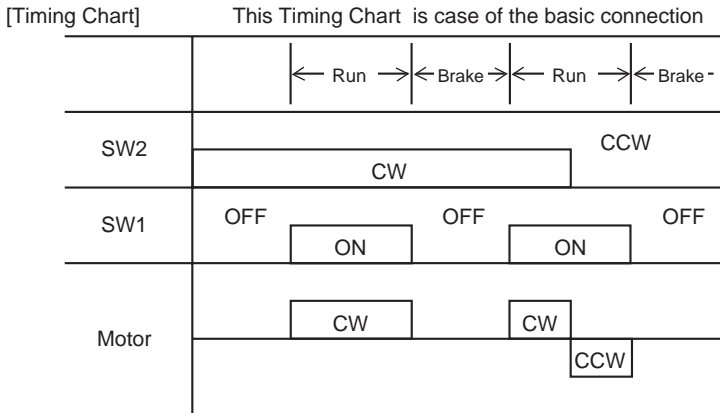

■ Starting and Stopping

SW1 operates motor and electromagnetic brake action.

Motor will rotate when SW1 is switched simultaneously to ON (short circuit). When SW1 is switched simultaneously to OFF (open), the motor stops immediately by electromagnetic brake and holds the load.

Note: When operating the electromagnetic brake, this may make a friction noise because this is the braking system by friction, but this is not a problem.

■ Direction of Rotation

[Single-phase motor] To rotate the motor in a clockwise (CW) direction, switch SW2 to CW.

To rotate it in a counter-clockwise (CCW) direction, switch SW2 to CCW.

[Three-phase motor] To change the direction of rotation, change any two connections between U, V and W.

■ Other ways of operating

Note: When driving a vertical load, this method cannot be applied because this may cause the load to fall.

• Hastening the motor's starting time

If the electromagnetic brake is left release, the motor can be started much faster.

Optimum timing for release of the brake is at least 10msec. before starting up the motor.

• Releasing Electromagnetic brake

If you wish to release the brake while the motor is stopped, apply voltage between only two orange lead wires.

The electromagnetic brake is released and the motor shaft can be rotated easily by hand.

6. Time Rating

Induction motors have a continuous rating.

Reversible motors have a 30 minutes rating. "30 min" is indicated on the nameplate.

7. Locked rotor burnout protection

This motor is equipped with one of two methods to prevent burning the motor as a result of abnormal heating.

■ Thermal protection ("TP" is stamped on the motor name plate)

The motor has an "auto reset" type thermal protector built into its motor coil. When the motor reaches a predetermined temperature, the internal thermal protector is activated and the motor is stopped.

In this stage, the electromagnetic brake is left released so that the motor does not keep hold of the load. Adopt another safety measure.

Always turn the power off before performing inspections.

Thermal protector activation range:

Power is turned off at 130°C (266°F) ±5°C (9°F)

Power is turned back on at 85°C (185°F) ±20°C (36°F)

8. Troubleshooting

When the motor is not functioning normally, perform an inspection covering the points listed in the table below.

If the inspection shows that everything is normal but the motor and control unit still are not functioning correctly, contact the nearest ORIENTAL MOTOR office.

Problem	Things to check
The motor does not rotate or motor rotates at low speed	<ol style="list-style-type: none"> 1. Is the correct voltage being supplied to the Motor? 2. Are lead wires properly and firmly connected? 3. Is the load too large? 4. If lead wires have been extended by using a terminal strip or terminal block, are the lead wires properly and firmly connected at all points? 5. For a single-phase motor is the provided capacitor connected as shown in the wiring diagram of page 4? 6. Is voltage applied to the brake lead wires?
The motor rotate correctly or properly	<ol style="list-style-type: none"> 1. Are lead wires properly and firmly connected? 2. If lead wires have been extended by using a terminal strip or terminal block, are the lead wires properly and firmly connected at all points? 3. For a single-phase motor is the provided capacitor connected as shown in the wiring diagram of page 4?
The motor rotates in the wrong direction	<ol style="list-style-type: none"> 1. Is the connection as shown in the wiring diagram? Check the wiring diagram of page 4 again. 2. The gearhead output shaft's rotation direction differs depending on the gearhead's deceleration ratio. Refer to the gearhead operation manual . 3. For a single-phase motor is the provided capacitor connected as shown in the wiring diagram of page 4? 4. Are you looking at the motor from the wrong side? Rotation is defined as viewed from the output shaftside.
The motor becomes extraordinarily hot (motor case temperature exceeds 90°C (194°F))	<ol style="list-style-type: none"> 1. Is the correct voltage being supplied to the motor? 2. Does the ambient temperature exceed the permissible range? 3. For a single-phase motor is the provided capacitor connected as shown in the wiring diagram of page 4?
The motor makes a strange noise	<ol style="list-style-type: none"> 1. Are the motor and gearhead correctly fastened? Refer to the gearhead operation manual. 2. Is the coupled gearhead the same pinion type as the motor shaft?

- Characteristics, specifications and dimensions are subject to change without notice.
- **Orientalmotor** is a trademark of Oriental Motor Co., Ltd.

© Copyright ORIENTAL MOTOR CO., LTD. 2008

Published in November 2022

- Please contact your nearest Oriental Motor office for further information.

ORIENTAL MOTOR U.S.A. CORP.
Technical Support Tel:800-468-3982
8:30am EST to 5:00pm PST (M-F)
www.orientalmotor.com

ORIENTAL MOTOR (EUROPA) GmbH
Schiesstraße 44, 40549 Düsseldorf, Germany
Technical Support Tel:00 800/22 55 66 22
www.orientalmotor.de

ORIENTAL MOTOR (UK) LTD.
Unit 5 Faraday Office Park, Rankine Road,
Basingstoke, Hampshire RG24 8QB UK
Tel:+44-1256347090
www.oriental-motor.co.uk

ORIENTAL MOTOR (FRANCE) SARL
Tel:+33-1 47 86 97 50
www.orientalmotor.fr

ORIENTAL MOTOR ITALIA s.r.l.
Tel:+39-02-93906347
www.orientalmotor.it

ORIENTAL MOTOR ASIA PACIFIC PTE. LTD.
Singapore
Tel:1800-842-0280
www.orientalmotor.com.sg

ORIENTAL MOTOR (MALAYSIA) SDN. BHD.
Tel:1800-806-161
www.orientalmotor.com.my

ORIENTAL MOTOR (THAILAND) CO., LTD.
Tel:1800-888-881
www.orientalmotor.co.th

ORIENTAL MOTOR (INDIA) PVT. LTD.
Tel:1800-120-1995 (For English)
1800-121-4149 (For Hindi)
www.orientalmotor.co.in

TAIWAN ORIENTAL MOTOR CO., LTD.
Tel:0800-060708
www.orientalmotor.com.tw

SHANGHAI ORIENTAL MOTOR CO., LTD.
Tel:400-820-6516
www.orientalmotor.com.cn

INA ORIENTAL MOTOR CO., LTD.
Korea
Tel:080-777-2042
www.inaom.co.kr

ORIENTAL MOTOR CO., LTD.
4-8-1 Higashiueno, Taito-ku, Tokyo
110-8536 Japan
Tel:+81-3-6744-0361
www.orientalmotor.co.jp