

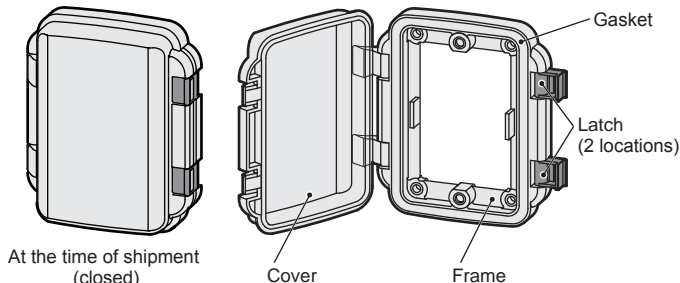

OPERATING MANUAL

Dust-proof, Splash-proof Type Front Cover

Product overview



At the time of shipment (closed)

[Accessory (supplied)] Driver mounting screws 2 pcs  
Material: Stainless steel
Size: M4 [nominal length 10 mm (0.39 in.)]

Applicable product

PCF12	BMU Series : 30 W, 60 W, 120 W
PCF12-B	US2 Series, US Series, BLU Series
PCF15-B	BMU Series : 200 W, 300 W, 400 W

Specifications of front cover

Degree of protection	IP64 (classification stated in IEC 60529)	
Material	Cover	Polycarbonate
	Gasket	Polyethylene (foam)
	Frame	Polybutylene terephthalate + Acrylonitrile-butadiene-styrene
	Latch	Polyacetal

• Hazardous substances: The products do not contain the substances exceeding the restriction values of RoHS Directive (2011/65/EU).

Safety precautions

The precautions described below are intended to prevent danger or injury to the user and other personnel through safe, correct use of the product. Use the product only after carefully reading and fully understanding these instructions.

 **Caution** Handling the product without observing the instructions that accompany a "Caution" symbol may result in injury or property damage.

Install the front cover to the flat and smooth mounting surface. Install it according to the tightening torque. The performance of ingress protection cannot be ensured, resulting in electric shock or damage to equipment.

Installation

Install the front cover to a flat metal plate.

Installation conditions

- Indoors
- Operating ambient temperature 0 to +50 °C (+32 to +122 °F)
- Operating ambient humidity 85% or less
- Area that is free of explosive atmosphere or free of atmosphere which contains strong acids, strong alkali or organic solvents (ethyl chloride, methyl chloride, cresol, etc.)
- Area free of radioactive materials
- Area free of damp or ozonic atmosphere
- Area not exposed to direct sun
- Area not subject to continuous vibration or excessive shocks

Panel cut-out [Unit: mm (in.)]

• PCF12, PCF12-B

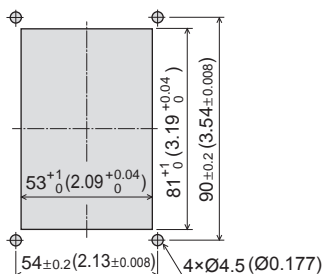

• PCF15-B

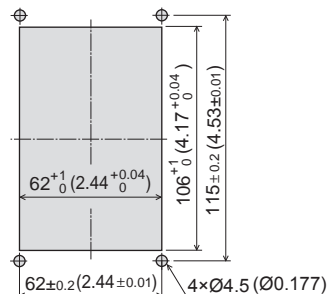

Thank you for purchasing an Oriental Motor product. This operating manual describes how to install the front cover.

- Use the product correctly after thoroughly reading this operating manual.
 - Be sure to read the operating manual of the applicable product before use.
- Only qualified and educated personnel should work with the product.

Precautions for use

- The waterproof performance of the front cover is designed assuming fresh water and tap water at normal temperature [+5 to +35 °C (+41 to +95 °F)]. Do not splash hot water or blow hot air.
- After close the cover, be sure to secure with two latches before use.
- Do not apply an excessive force when opening or closing the cover and latches.
- Wipe off moisture to prevent infiltration of water into the cover when opening it.
- Clean up the cover with water or ethyl alcohol.
- Check aged deterioration of the gasket or loosening of screws periodically in order to ensure the waterproof performance.

Installing the front cover

Install the front cover as shown below. The figures below show the **PCF12** and **PCF12-B**. The front cover is bilaterally symmetrical and it can also install in right-opening.

- 1 Install the front cover to the mounting plate.
Provide screws to install the front cover (screws are not included).

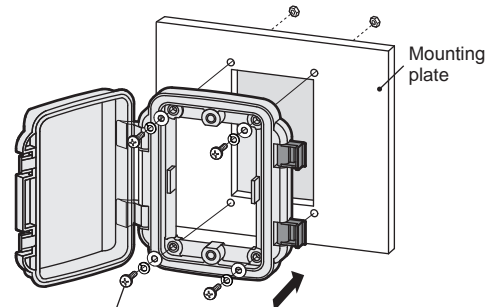

Frame thickness of screw hole 5 mm (0.20 in.)
Tightening torque: 0.5 to 0.7 N·m (4.4 to 6.1 lb-in)

- 2 Install the driver using the supplied screws.
For the **PCF15-B**, the position of the mounting holes is different.

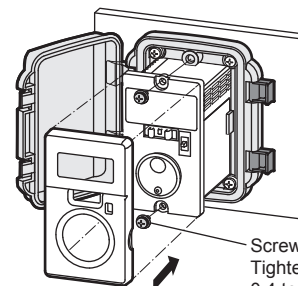

* 0.5 to 0.7 N·m (4.4 to 6.1 lb-in) for **PCB15-B**

Caution Be sure to use the supplied screws. Using screws of longer nominal length may cause insufficient mounting.

- 3 Close the cover and secure with the latches.

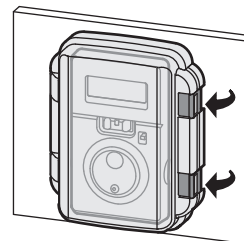

Characteristics, specifications and dimensions are subject to change without notice.

© Copyright ORIENTAL MOTOR CO., LTD. 2015

ORIENTALMOTOR CO., LTD.