

OPERATING MANUAL

KII Series Induction Motor

200 W



Introduction

Before using the product

Only qualified personnel of electrical and mechanical engineering should work with the product. Use the product correctly after thoroughly reading the section "Safety precautions." In addition, be sure to observe the contents described in warning, caution, and note in this manual.

The product described in this manual is designed and manufactured to be incorporated in general industrial equipment. Do not use for any other purpose. Oriental Motor Co., Ltd. is not responsible for any compensation for damage caused through failure to observe this warning.

Safety precautions

The precautions described below are intended to ensure the safe and correct use of the product, and to prevent the user and other personnel from exposure to the risk of injury. Use the product only after carefully reading and fully understanding these instructions.

WARNING

Handling the product without observing the instructions that accompany a "WARNING" symbol may result in serious injury or death.

CAUTION

Handling the product without observing the instructions that accompany a "CAUTION" symbol may result in injury or property damage.

Note

The items under this heading contain important handling instructions that the user should observe to ensure safe use of the product.

WARNING

- Do not use the product in explosive or corrosive environments, in the presence of flammable gases or near combustibles. Doing so may result in fire, electric shock, or injury.
- Only qualified and educated personnel should be allowed to perform installation, connection, operation and inspection/troubleshooting of the product. Handling by unqualified and uneducated personnel may result in fire, electric shock or injury.
- Do not transport, install, connect, or inspect the product while the power is supplied. Always turn off the power before carrying out these operations. Accidental contact may result in electric shock.
- The motor is Class I equipment. Install the motor so that it is out of the direct reach of users, or ground if users can touch it. Failure to do so may result in electric shock.
- Always keep the power supply voltage within the specified range. Failure to do so may result in fire or electric shock.
- Securely connect and ground in accordance with the connection diagram. Failure to do so may result in fire or electric shock.
- Do not forcibly bend, pull, or pinch the cable or lead wires. Doing so may result in fire or electric shock.
- Turn off the power in the event of a power failure. Otherwise, the motor may suddenly start when the power is restored, causing injury or damage to equipment.
- Do not disassemble or modify the motor. Doing so may result in electric shock or injury.

CAUTION

- Do not use the motor beyond the specifications. Doing so may result in electric shock, injury, or damage to equipment.
- Do not touch the motor while operating or immediately after stopping. The surface of the motor is hot and it may cause a skin burn(s).
- Do not lift up the product by holding the output shaft, the cable, or the lead wires. Doing so may result in injury.
- Do not touch the motor output shaft (shaft end or pinion) with bare hands. Doing so may result in injury.
- Keep the area around the motor free of combustible materials. Failure to do so may result in fire or a skin burn(s).
- Do not leave anything around the motor that would obstruct ventilation. Doing so may result in damage to equipment.
- The motor does not have a built-in overheat protection device. Provide a protection device externally.
- When installing the motor in equipment, exercise caution not to pinch your fingers or other parts of your body between the product and equipment. Injury may result.
- Do not touch the rotating part (output shaft) while operating the motor. Doing so may result in injury.
- Securely install a load to the output shaft. Inappropriate installation may result in injury.
- When an abnormality is generated, turn off the power immediately. Failure to do so may result in fire, electric shock, or injury.
- The motor surface temperature may exceed 70 °C (158 °F) even under normal operating conditions. If the operator is allowed to approach the operating motor, attach a warning label on a conspicuous position as shown in the figure. Failure to do so may result in a skin burn(s).



Warning label

Thank you for purchasing an Oriental Motor product.

This Operating Manual describes product handling procedures and safety precautions.

- Please read it thoroughly to ensure safe operation.
- Always keep the manual where it is readily available.

Preparation

Checking the product

Verify that the items listed below are included. Report any missing or damaged items to the branch or sales office from which you purchased the product.

- Motor 1 unit
(the combination type comes with the motor and gearhead pre-assembled)
- Parallel key 1 piece (only for the combination type)
- Mounting screw 1 set
(only for the combination type-parallel shaft gearhead)
Hexagonal socket head screw, plain washer, spring washer: each 4 pieces
- OPERATING MANUAL (this document) 1 copy

Checking the model name

Check the motor model and the gearhead model against the model name shown on their nameplates, respectively.

Tell us the model name, product serial number, and manufacturing date when you contact us. The figure shows a product assembled a right-angle gearhead.

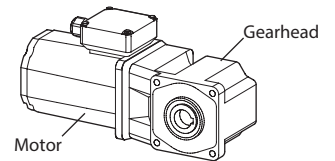

- The box (■) in the model name indicates a code representing the power supply voltage.

JS: Three-phase 200 VAC 50/60 Hz

ES: Three-phase 220/230/240 VAC 50/60 Hz

EU: Three-phase 380/400/415 VAC 50/60 Hz

- The box (□) in the model name indicates a number representing the gear ratio.

Combination type-parallel shaft gearhead

| Model | Motor model | Gearhead model |
|----------------|----------------|----------------|
| 71K200V■3T2-□S | 71K200VGV-■3T2 | 7GV□BS |

Combination type-right angle hollow shaft hypoid gear GV gearhead

| Model | Motor model | Gearhead model |
|------------------|----------------|----------------|
| 71K200V■3T2-□RHS | 71K200VGV-■3T2 | 7GV□RHS |

Round shaft type

| Model |
|----------------|
| 71K200VAS-■3T2 |

Information about nameplate

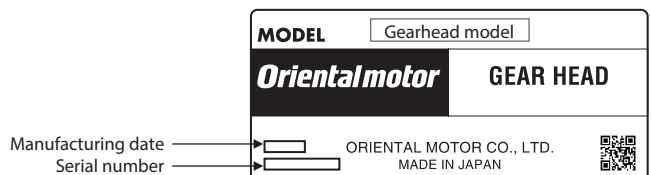
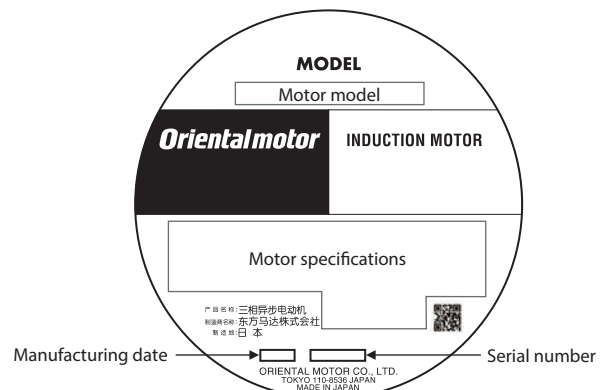

Installation

Location for installation

Install the product in a well-ventilated location that provides easy access for inspection.

- Indoors
 - Operating ambient temperature: -10 to +40 °C [+14 to +104 °F] (non-freezing)
 - Operating ambient humidity: 85% or less (non-condensing)
 - Area free of explosive atmosphere, toxic gas (such as sulfuric gas), or liquid
 - Area not exposed to direct sun
 - Area free of excessive amount of dust, iron particles or the like
 - Area not subject to oil (oil droplets) or chemicals
- This product can be used in an environment where it is splashed with water (excluding the mounting surface of the round shaft type). However, do not use it under water or in high water pressure.
- Area free of excessive salt
 - Area not subject to continuous vibrations or excessive shocks
 - Area free of excessive electromagnetic noise (from welders, power machinery, etc.)
 - Area free of radioactive materials, magnetic fields or vacuum
 - Altitude: Up to 1000 m (3300 ft.) above sea level

Note

On rare occasions, grease may ooze out from the gearhead. If there is concern over possible environmental contamination resulting from the leakage of grease, provide an oil tray or similar oil catching mechanism in order not to cause a secondary damage. Grease leakage may lead to problems in the user's equipment or products.

Installation methods

Note

Do not install the motor to the mounting hole diagonally or assemble the motor forcibly. Doing so may damage the motor.

Combination type-parallel shaft gearhead

Secure the product through four mounting holes using the included mounting screw set. Install so that there is no gap between the product and the mounting plate.

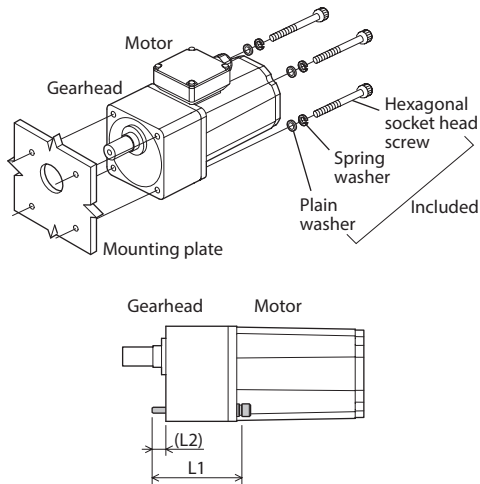

Mounting screw set (included)

| Gear ratio | Hexagonal socket head screw | | L2 | Tightening torque |
|------------|-----------------------------|-------------------|------------------|----------------------|
| | Screw size | L1 | | |
| 5 to 20 | M8 | 85 mm (3.35 in.) | 11 mm (0.43 in.) | 12.0 N-m (106 lb-in) |
| 30, 50 | | 100 mm (3.94 in.) | 14 mm (0.55 in.) | |
| 100 | | 110 mm (4.33 in.) | 10 mm (0.39 in.) | |

Removing and assembling the gearhead

This is the procedure to replace the gearhead or to change the position of the terminal box.

Removing the gearhead from the motor

Remove the hexagonal socket head screws (2 places) assembling the motor and gearhead, and detach the gearhead from the motor.

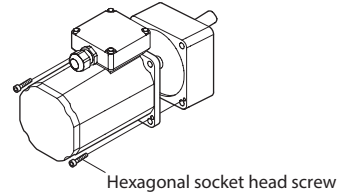

Assembling the gearhead to the motor

1. Keep the pilot sections of the motor and gearhead in parallel, and assemble the gearhead with the motor while slowly rotating it clockwise/counterclockwise. At this time, note so that the pinion of the motor output shaft does not hit the gearhead or gears strongly.
2. Check that there is no gap between the motor and the gearhead, and tighten them with hexagonal socket head screws (2 places).

Screw size: M3
Tightening torque: 0.6 N-m (5.3 lb-in)

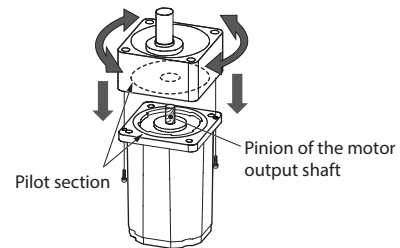

Assemble the gearhead to the motor in a condition where the motor output shaft is in an upward direction.

Note

- Do not forcibly assemble the motor and gearhead. Also, prevent metal objects or foreign substances from entering in the gearhead. The pinion of the motor output shaft or gear may be damaged, resulting in noise or shorter service life.
- An O-ring is attached to the motor pilot section. Assemble the motor and gearhead carefully by not pinching the O-ring. Pinching the O-ring may cause grease to leak from the gearhead.

Combination type-right angle hollow shaft hypoid gear GV gearhead

Secure the product using screws (not included) through the four mounting holes. Install so that there is no gap between the product and the mounting plate.

Screw size: M8
Tightening torque: 15.5 N-m (137 lb-in)

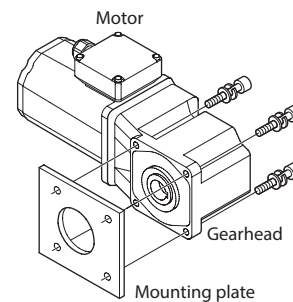

Note

- When using the gearhead flange to mount the product to equipment, proper alignment between the hollow output shaft inner diameter section and the load shaft is necessary. Insufficient alignment may result in damage to the gearhead internal bearings.
- The mounting boss of the output shaft is finished to be $\varnothing 58\text{h}8$, so use it as a guide when centering.

Removing and assembling the gearhead

This is the procedure to replace the gearhead or to change the position of the terminal box.

Removing the gearhead from the motor

Remove the hexagonal socket head screws (4 places) assembling the motor and gearhead, and detach the gearhead from the motor.

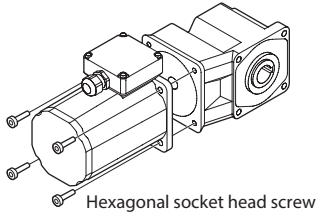

Assembling the gearhead to the motor

1. Keep the pilot sections of the motor and gearhead in parallel, and assemble the gearhead with the motor while slowly rotating it clockwise/counterclockwise. At this time, note so that the pinion of the motor output shaft does not hit the gearhead or gears strongly.
2. Check that there is no gap between the motor and the gearhead, and tighten them with hexagonal socket head screws (4 places).

Screw size: M8
Tightening torque: 15.5 N-m (137 lb-in)

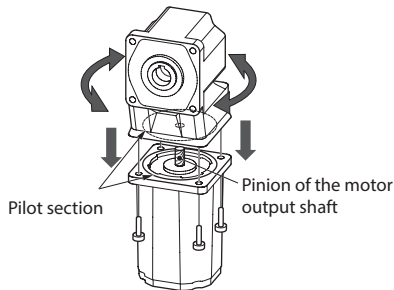

Assemble the gearhead to the motor in a condition where the motor output shaft is in an upward direction.

Note

- Do not forcibly assemble the motor and gearhead. Also, prevent metal objects or foreign substances from entering in the gearhead. The pinion of the motor output shaft or gear may be damaged, resulting in noise or shorter service life.
- Do not allow dust to attach to the pilot sections of the motor and gearhead. Also, assemble the motor and gearhead carefully by not pinching the O-ring at the motor pilot section. If the O-ring is crushed or severed, grease may leak from the gearhead.

• Round shaft type

Secure the product using hexagonal socket head screws (not included) through the four mounting holes. Install so that there is no gap between the product and the mounting plate.

Screw size: M8
Tightening torque: 12.0 N-m (106 lb-in)

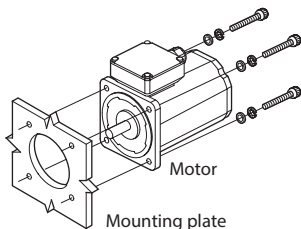

■ Installing a load

• Combination type-parallel shaft gearhead

The gearhead output shaft is finished to an outer diameter tolerance of h7 and is provided with a key slot for installing the transmission parts. Be sure to fit the output shaft and the transmission parts by a clearance fit when installing. In addition, always fix the parallel key to the output shaft with a screw to prevent the transmission parts from rattling or spinning.

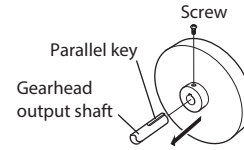

Note

Do not apply excessive force onto the gearhead output shaft using a hammer or other tools. Doing so may cause damage to the output shaft or bearings.

• When using the output shaft end tapped hole of a gearhead

Use a tapped hole provided at the end of the output shaft as an auxiliary means for preventing the transfer mechanism from disengaging.

Output shaft end tapped hole: M6, effective depth 12 mm (0.47 in)

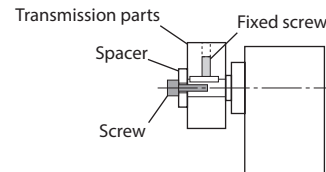

• Combination type-right angle hollow shaft hypoid gear GV gearhead

The installation method of a load varies depending on the shape of a load shaft. Refer to the figures below.

The output shaft is finished to an inner diameter tolerance of H8, and is provided a key slot for installing a load shaft. A load shaft tolerance of h7 is recommended. Apply molybdenum disulfide grease on the surface of the load shaft and the inner walls of the hollow output shaft to prevent seizure.

After installing the load, attach the safety cover.

[Tightening torque: 0.35 to 0.45 N-m (3.0 to 3.9 lb-in)]

• Recommended load shaft dimensions

| Hollow output shaft inner diameter (H8) | Recommended load shaft dimensions (h7) |
|--|--|
| $\varnothing 25^{+0.033}_0$ mm ($\varnothing 0.9843^{+0.0013}_0$ in.) | $\varnothing 25_{-0.021}^0$ mm ($\varnothing 0.9843_{-0.0008}^0$ in.) |

• Stepped load shaft

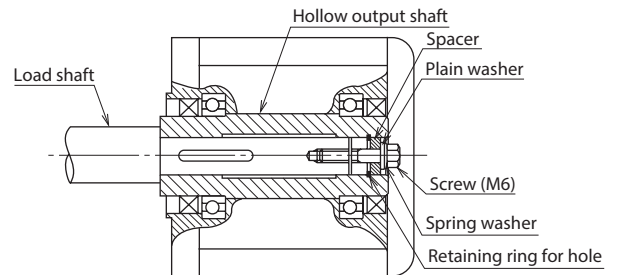

• Non-stepped load shaft

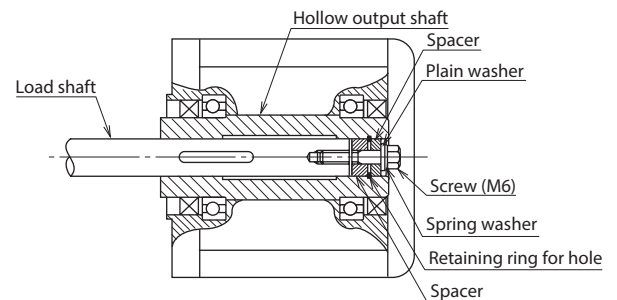

Note

Do not apply excessive or abrupt force to the hollow output shaft when inserting a load shaft into the hollow output shaft. Excessive or abrupt force may damage the gearhead internal bearings.

■ Permissible radial load and permissible axial load

The radial load and axial load have a great influence on the life of the bearings and strength of the shaft.

Do not exceed the permissible radial load and permissible axial load. Refer to Oriental Motor Website for details.

Connection

Insulate the connection part of the power supply.
Be sure to ground using the Protective Earth Terminal (⊕) inside the terminal box.

Note Be sure to use the screw for protective earth terminal attached on the product.

Connection diagram

CAUTION

The motor does not have a built-in overheat protection device.
Use an electromagnetic switch to prevent the motor from burning when an overload is applied or the output shaft is locked. (Refer to p.5 for details.)

The figure shows a connection diagram when the motor is directly connected to a power supply.
The symbols U, V, and W represent the terminal symbols inside the terminal box.

[Electromagnetic switch]

MC: Electromagnetic contactor
THR: Thermal relay

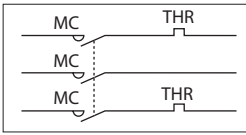

[Measures for surge voltage]

Connect the CR circuit for surge suppression to protect contacts as shown in the figure.

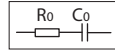

- When the motor rated voltage is 200 to 240 VAC
Ro = 5 to 200 Ω
Co = 0.1 to 0.2 μF 250 VAC
This is provided as a peripheral equipment (sold separately).
Model: **EPCR1201-2**
- When the motor rated voltage is 380 to 415 VAC
Ro = 5 to 200 Ω
Co = 0.1 to 0.2 μF 450 VAC

Combination type-parallel shaft gearhead, round shaft type

The output shaft rotates in the following direction if connected as shown in the figure.
Gear ratio **5, 10, 15, 20, 100**, and round shaft type: CW (clockwise direction)
Gear ratio **30** and **50**: CCW (counterclockwise direction)
Check the motor model name and gear ratio before connecting.

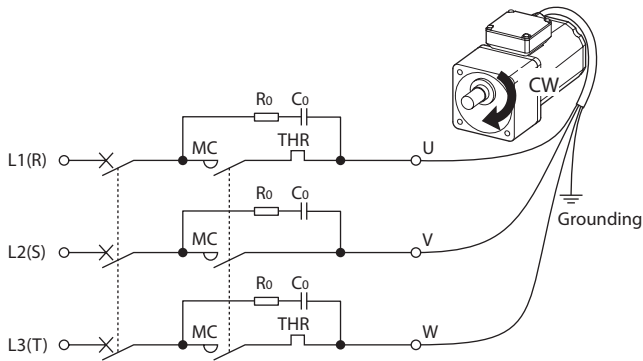

To change the direction of rotation, change any two connections between R, S and T.

Combination type-right angle hollow shaft hypoid gear GV gearhead

The output shaft rotates in the counterclockwise direction (CCW) if connected as shown in the figure.

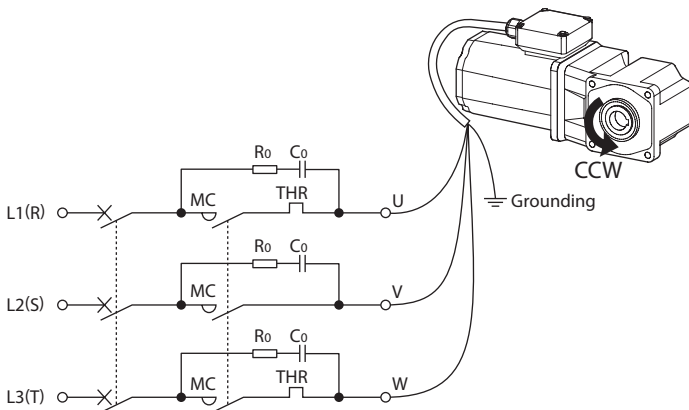

To change the direction of rotation, change any two connections between R, S and T.

Connecting to the terminal block

Remove the terminal box cover to connect a cable.
Cables for connection are available as peripheral equipments (sold separately).

- If the O-ring having set on the matching surface of the terminal box cover was detached, install it firmly in the groove of the terminal box cover.
- After connecting the cable, securely tighten with the tightening torque shown in the table below.

Note

- To maintain the sealing performance of the terminal box, keep the applicable cable diameter and the tightening torque for screws.
- Secure the cable exposed to the outside of the motor so that no stress is applied.

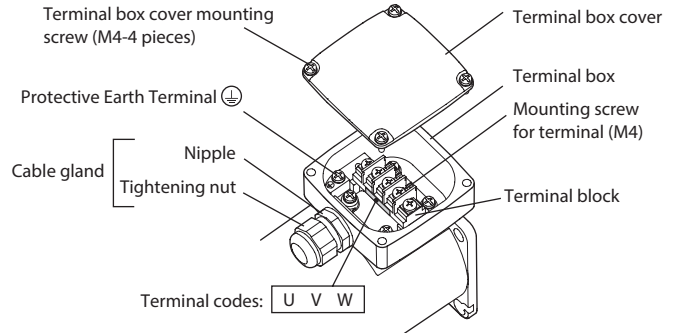

Tightening torque

| | |
|-----------------------------------|------------------------------------|
| Terminal box cover mounting screw | 1.0 to 1.5 N·m (8.8 to 13.2 lb-in) |
| Mounting screw for terminal | 1.0 to 1.2 N·m (8.8 to 10.6 lb-in) |
| Tightening nut | 2.0 to 2.5 N·m (17.7 to 22 lb-in) |
| Nipple | 2.0 to 2.5 N·m (17.7 to 22 lb-in) |
| Protective Earth Terminal | 1.0 to 1.5 N·m (8.8 to 13.2 lb-in) |

- Use the following cable and crimp terminal when connecting the cable on the terminal block.

Applicable crimp terminal: Round crimp terminal with insulation cover
Applicable cable diameter: Ø7 to Ø13 mm (Ø0.28 to Ø0.51 in.)*
Applicable lead wire: AWG18 (0.75 mm²) or thicker
* Round shaft type: Ø8 to Ø13 mm (Ø0.31 to Ø0.51 in.)

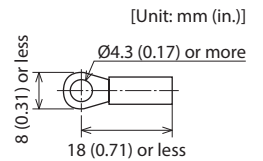

Changing the cable outlet position

The cable outlet position can be changed to the left or right 90-degree direction or the 180-degree direction.
When changing the cable outlet position, loosen the terminal box cover mounting screw, rotate the terminal box to change the mounting direction.

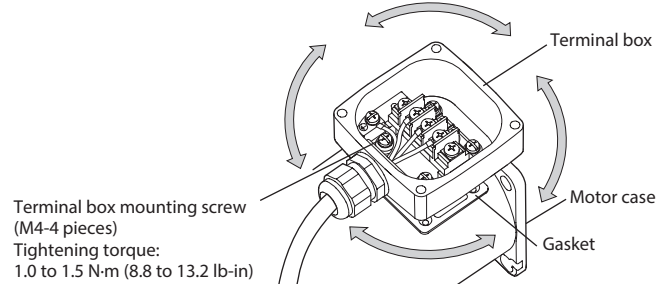

Note

- Be sure to use the gasket attached.
- Assemble so that foreign objects are not entered between the terminal box and the motor case.

Operation

The motor rotates when the power supply is turned on.
For protection against electric shock, do not turn on the power supply until the wiring is completed.

Note

- Make sure that the motor case temperature does not exceed 90°C (194 °F) when operating the motor. Operating the motor in a state where the case temperature exceeds 90°C (194 °F) causes the lives of windings and ball bearings of the motor to shorten. Measure to check the motor case temperature using a thermometer, thermo tape or thermocouple.
- When an ambient temperature is low, since the load torque may increase by the viscosity increment of the oil seal or grease, the motor may take time to start rotating or may fall the rotation speed. However, if the operation is continued for a while, the oil seal or grease will be warmed up, and the motor can be driven at the normal rotation speed.
- Do not perform instantaneous bidirectional operation of the motor. Doing so may damage the motor or gearhead.
- Do not stop the shaft rotation of motor/gearhead forcibly by hitting an object. Stopping in such a way may cause impact, leading to damage to the gearhead.

Burning protection at overload/locked condition

When connecting to a power supply

- Always connect an electromagnetic switch.
Connect the electromagnetic switch according to the operating manual of the electromagnetic switch.
- Set the motor rated current for the setting current of the thermal relay.
The motor rated current is listed on the nameplate.
- For an electromagnetic switch, use any of the following products or equivalent.

[Fuji Electric FA Components & Systems Co., Ltd.]

| Motor output power | Part number |
|-------------------------------------|---------------|
| 200 W, rated voltage 200 to 240 VAC | SC11AAN-□10TK |
| 200 W, rated voltage 380 to 415 VAC | SC11AAN-□10TH |

- The box (□) in the part number indicates a code representing the coil voltage code. Use the product having the coil voltage code which satisfies the motor rated voltage.

| Rated voltage | | Coil voltage code |
|----------------|----------------|-------------------|
| 50 Hz | 60 Hz | |
| 200 VAC | 200 to 220 VAC | 2 |
| 200 to 220 VAC | 220 to 240 VAC | M |
| 220 to 240 VAC | 240 to 260 VAC | P |
| 346 to 380 VAC | 380 to 420 VAC | S |
| 380 to 400 VAC | 400 to 440 VAC | 4 |
| 415 to 440 VAC | 440 to 480 VAC | T |

[Mitsubishi Electric Corporation]

| Motor output power | Part number |
|-------------------------------------|--------------------------|
| 200 W, rated voltage 200 to 240 VAC | MSO-T10 0.9A 200V AC200V |
| 200 W, rated voltage 380 to 415 VAC | MSO-T10 0.5A 400V AC400V |

When connecting to an inverter

Be sure to set the electronic thermal relay according to the operating manual of the inverter. Unless the electronic thermal relay is set, a burnout may result.

When using the motor with an inverter

When the motor is used with connecting an inverter, perform the following settings to the inverter.

When driving the inverter, use it at the setting frequency 120 Hz or lower.

Setting for motor

| | |
|-----------------------------------|---|
| Electronic thermal relay function | Set the rated current listed on the motor nameplate based on the base frequency and the voltage applied to the motor. |
| Setting the applicable motor | Constant-torque motor or inverter motor |
| Motor capacity | Motor rated output power If the setting value in the inverter does not exist, set the nearest value. |
| Number of motor poles | 4 poles |

Operating ambient temperature of motor: 0 to +40°C (+32 to +104 °F)
(Only for motors with a right-angle gearhead)

Note on using the motor with an inverter

Use the input voltage to the inverter at or below 240 VAC. Use **7IK200VEU** at or below 415 VAC. Using the motor in excess of these voltages may cause the insulation of the motor windings to deteriorate, resulting in damage to the motor.

Time rating

Continuous operation can be performed (continuous rating).

Maintenance and inspection

Inspection

It is recommended that periodic inspections would be conducted for the items listed below after each operation of the motor.
When an abnormality is generated, discontinue any use and contact your nearest Oriental Motor sales office.

Inspection item

- Check if any of the mounting screws of the motor is loose.
- Check if the bearing part (ball bearings) of the motor generates unusual noises.
- Check if the bearing part (ball bearings) or gear meshing part of the gearhead generates unusual noises.
- Check if the output shaft and the load shaft are out of alignment.

Warranty

Check on the Oriental Motor Website for the product warranty.

Disposal

Dispose the product correctly in accordance with laws and regulations, or instructions of local governments.

Troubleshooting and remedial actions

When the motor cannot be operated properly, refer to the contents described in this section and take an appropriate remedial action. If the problem persists, contact your nearest Oriental Motor sales office.

| Phenomenon | Check items |
|--|---|
| The motor does not rotate. | <ul style="list-style-type: none"> Check the power supply voltage. Connect the power supply properly. |
| The motor sometimes rotates and stops. | <ul style="list-style-type: none"> If terminal blocks or crimping terminals are used, check if poor connection is occurred. Keep a load at or below the permissible value. |
| The motor rotates in the direction opposite to the specified direction. | <ul style="list-style-type: none"> Check the connection. The rotation direction represents that when viewed from the output shaft side. Check the direction from which the product is viewed. |
| The motor temperature is extraordinarily high. [The motor case temperature exceeds 90 °C (194 °F).] | <ul style="list-style-type: none"> Check the power supply voltage. Reconsider the ventilation condition. |
| Noise is generated. | <ul style="list-style-type: none"> Assemble the motor and gearhead properly. |

Peripheral equipment (sold separately)

Torque arm

Model: **SOT6**

The mounting holes of the torque arm should be machined according to the dimensions shown in the figure below.

[Unit: mm (in.)]

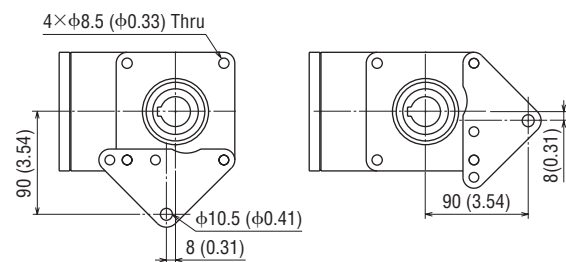

Specifications

Check on the Oriental Motor Website for the product specifications.

Regulations and standards

■ UL Standards, CSA Standards

This product is recognized by UL under the UL and CSA Standards.
The motor model name represents the model that conforms to the standards.

| Applicable standards | Certification body | Standards File No. |
|----------------------|--------------------|--------------------|
| UL 1004-1 | UL | E62327 |
| CSA C22.2 No.100 | | |

- Thermal class: 130 (B)

■ China Compulsory Certification System (CCC System)

This product is affixed with the CCC Marking under the China Compulsory Certification System.

It is also certified by CQC.

Applicable standards: GB/T 12350

■ CE Marking

This product is affixed with the CE Marking under the Low Voltage Directive.

● Low Voltage Directive

- Applicable standards

EN 60034-1, EN 60034-5, EN 60664-1

- Installation conditions (EN Standards)

Overvoltage category: II

Pollution degree: 3

Class I equipment

If the overvoltage category III is required according to the equipment, supply a rated voltage to the motor via the insulation transformer.

- Motor temperature rise tests

The temperature rise tests stipulated in the standards are conducted in a state where a motor is mounted on a heat radiation plate instead of attaching a gearhead. The size, thickness and material of the heat radiation plates are as follows.

| Size | Thickness | Material |
|----------------------------|-----------------|----------------|
| 250x250 mm (9.84x9.84 in.) | 6 mm (0.24 in.) | Aluminum alloy |

● Ecodesign Directive

This product does not apply to the energy efficiency standards because it is a totally enclosed non-ventilated (TENV) motor that falls under the requirements of Article 2-(2)-(I) of Commission Regulation (EU) 2019/1781.

■ RoHS Directive

The products do not contain the substances exceeding the restriction values of RoHS Directive (2011/65/EU).

■ Electrical Appliance and Material Safety Law

200/220/230/240 VAC types : The round shaft motor type bears a  mark.

- Unauthorized reproduction or copying of all or part of this manual is prohibited.
- Oriental Motor shall not be liable whatsoever for any problems relating to industrial property rights arising from use of any information, circuit, equipment or device provided or referenced in this manual.
- Characteristics, specifications and dimensions are subject to change without notice.
- While we make every effort to offer accurate information in the manual, we welcome your input. Should you find unclear descriptions, errors or omissions, please contact the nearest office.
- **Orientalmotor** is a registered trademark or trademark of Oriental Motor Co., Ltd., in Japan and other countries.

© Copyright ORIENTAL MOTOR CO., LTD. 2020

Published in April 2021

- Please contact your nearest Oriental Motor office for further information.

ORIENTAL MOTOR U.S.A. CORP.
Technical Support Tel:800-468-3982
8:30am EST to 5:00pm PST (M-F)
www.orientalmotor.com

ORIENTAL MOTOR (EUROPA) GmbH
Schiebsstraße 44, 40549 Düsseldorf, Germany
Technical Support Tel:00 800/22 55 66 22
www.orientalmotor.de

ORIENTAL MOTOR (UK) LTD.
Tel:+44-1256347090
www.oriental-motor.co.uk

ORIENTAL MOTOR (FRANCE) SARL
Tel:+33-1 47 86 97 50
www.orientalmotor.fr

ORIENTAL MOTOR ITALIA s.r.l.
Tel:+39-02-93906347
www.orientalmotor.it

ORIENTAL MOTOR CO., LTD.
4-8-1Higashiueno, Taito-ku, Tokyo 110-8536
Japan
Tel:+81-3-6744-0361
www.orientalmotor.co.jp

ORIENTAL MOTOR ASIA PACIFIC PTE. LTD.
Singapore
Tel:1800-842-0280
www.orientalmotor.com.sg

ORIENTAL MOTOR (MALAYSIA) SDN. BHD.
Tel:1800-806-161
www.orientalmotor.com.my

ORIENTAL MOTOR (THAILAND) CO., LTD.
Tel:1800-888-881
www.orientalmotor.co.th

ORIENTAL MOTOR (INDIA) PVT. LTD.
Tel:1800-120-1995 (For English)
1800-121-4149 (For Hindi)
www.orientalmotor.co.in

TAIWAN ORIENTAL MOTOR CO., LTD.
Tel:0800-060708
www.orientalmotor.com.tw

SHANGHAI ORIENTAL MOTOR CO., LTD.
Tel:400-820-6516
www.orientalmotor.com.cn

INA ORIENTAL MOTOR CO., LTD.
Korea
Tel:080-777-2042
www.inaom.co.kr