

Motorized Actuator

Electric Gripper

- **EH Series**
-

Function Setting Edition

Thank you for purchasing an Oriental Motor product.
This Manual describes product handling procedures and safety precautions.

- Please read it thoroughly to ensure safe operation.
- Always keep the manual where it is readily available.

Table of contents



1	Introduction	3
1-1	Before use.....	3
1-2	How to use this manual.....	3
1-3	Related operating manuals.....	3
1-4	Setting procedure.....	4
2	When using the EH Series 2-finger type	5
2-1	Traveling direction of the moving part.....	5
2-2	Setting of travel amount.....	6
2-3	Parameter lists	7
	■ How to read the table.....	7
	■ Mechanism limit	8
	■ EH3-AZAKH	9
	■ EH4-AZAKH	11
2-4	Operation	13
	■ Push-motion return-to-home operation	13
	■ Push-motion operation.....	14
3	When using the EH Series 3-finger type	15
3-1	Traveling direction of the moving part... ..	15
3-2	Setting of travel amount.....	15
	■ Setting example.....	16
3-3	Setting of gripping force.....	17
3-4	Parameter list	18
	■ How to read the table.....	18
	■ EH4T-AZAK, EH4T-AZAKH.....	18
3-5	Operation	20
	■ Push-motion return-to-home operation	20
	■ Push-motion operation.....	21

1 Introduction

1-1 Before use

Only qualified personnel of electrical and mechanical engineering should work with the product. Use the product correctly after thoroughly reading the section "Safety precautions" on the OPERATING MANUAL Actuator. In addition, be sure to observe the contents described in caution and note in this manual. The motorized actuators described in this manual have been designed and manufactured to be incorporated in general industrial equipment. Do not use for any other purpose. Oriental Motor Co., Ltd. is not responsible for any damage caused through failure to observe this warning.

Notation on this manual

 CAUTION	Handling the product without observing the instructions that accompany a "CAUTION" symbol may result in injury or property damage.
 Note	The items under this heading contain important handling instructions that the user should observe to ensure the safe use of the product.
 memo	The items under this heading contain related information and contents to gain a further understanding of the text in this manual.

1-2 How to use this manual

This manual explains about parameters required for operation of motorized actuators. Use it in the following cases.

- To check the factory setting for parameters.
- To check the upper limit values for parameters.
- To change the traveling direction of the moving part.
- To perform push-motion return-to-home operation.
- To perform push-motion operation.

1-3 Related operating manuals

For operating manuals, download from Oriental Motor Website Download Page or contact your nearest Oriental Motor sales office.

- **EH** Series OPERATING MANUAL Actuator
- Motorized Actuator Electric Gripper
Function Setting Edition (this document)
- **AZ** Series/Motorized actuator equipped with **AZ** Series
OPERATING MANUAL Function Edition

Refer to the operating manual of the driver for contents not described in these manuals.

1-4 Setting procedure

The motorized actuator equipped with the **AZ Series** can be used with the parameters at the time of shipment.

1	Install and connect a motorized actuator and a driver.
2	Connect and start the support software MEXE02.
3	<p>Copy the ABZO information (fixed value) to the driver.</p> <p>Parameters such as the traveling direction and minimum travel amount have been set in the ABZO sensor at the time of shipment. Using the MEXE02 software, match the ABZO information (fixed value) and the setting value of the driver parameter.</p>
4	Set the software limit when no sensor is used.
5	Write the set data to the driver.
6	Check the movement of the motorized actuator.
7	Save the set data.

2 When using the EH Series 2-finger type

2-1 Traveling direction of the moving part

The traveling direction of the moving part varies depending on the setting of the travel amount or the input method of the pulse signal. Check in the table.

The table describes examples when an actuator is used with the factory setting.

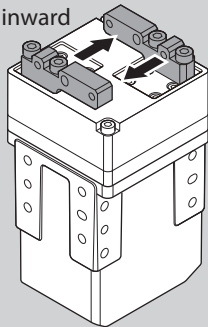
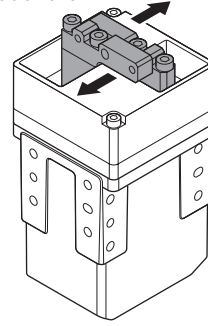
Setting	Traveling direction
<p>Operation by setting of parameter Set the travel amount to the positive (+) direction.</p>	<p>Moves inward</p> 
<p>Operation by pulse signal</p> <ul style="list-style-type: none"> • 2-pulse input mode Input the pulse signal to the CW input. • 1-pulse input mode Input the pulse signal to the PLS input when the DIR input is ON. 	
<p>Operation by setting of parameter Set the travel amount to the negative (-) direction.</p>	<p>Moves outward</p> 
<p>Operation by pulse signal</p> <ul style="list-style-type: none"> • 2-pulse input mode Input the pulse signal to the CCW input. • 1-pulse input mode Input the pulse signal to the PLS input when the DIR input is OFF. 	

2-2 Setting of travel amount



The operation data and parameters are set for one side of the moving parts (fingers).

- **Setting with the absolute position**

Set the travel amount of the moving part (finger) with reference to the home position.

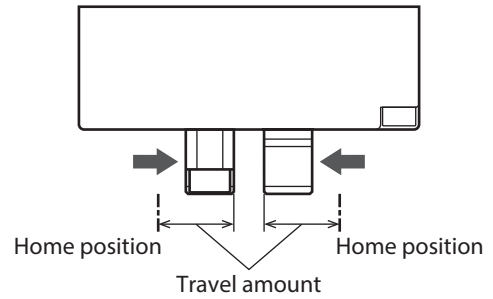

- **Setting with the relative position**

Set the travel amount of the moving part (finger) with reference to the present position.

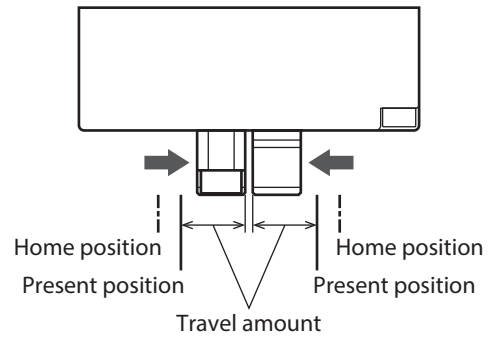

- **Setting example: When the travel amount is set to 5 mm**

The moving parts move by 5 mm each even if they start moving from any position.

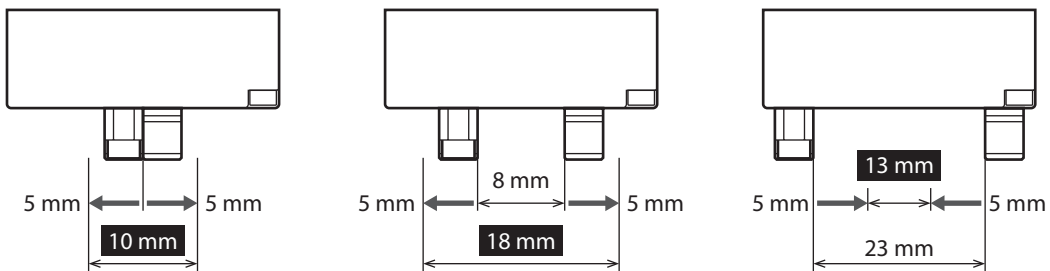

2-3 Parameter lists

The motorized actuator equipped with the AZ Series can be used with the parameters at the time of shipment.



- Set the operating speed by checking the specification of the maximum speed.
- The maximum speed may decrease depending on the ambient temperature or the length of the cable for motor.
- When using in combination with the pulse input type driver:
Use the function setting switch No.1 (resolution setting) with the factory setting as it is. If it is changed, the ABZO information does not apply and the actuator will operate at a certain resolution.

■ How to read the table

Parameters that have set a value dedicated for the motorized actuator are described on p.9 and later. Setting the specified values enables operation that satisfies the specifications of the motorized actuator.

The minimum travel amount is set to "0.01 mm" at the time of shipment. It makes easier to calculate the travel amount and others since the actuator moves 0.01 mm per one step.

Item	Factory setting	
	Unit of travel amount: mm	Unit of travel amount: step
(JOG) Operating speed	2.04 [mm/s]	204 [Hz]
(JOG) Acceleration/deceleration	0.70500 [m/s ²]	70.500 [kHz/s]
(JOG) Starting speed	0.63 [mm/s]	63 [Hz]

These values are set in the motorized actuator at the time of shipment.

Set the values in this column when setting in unit of step.

■ Mechanism limit

The home position is set at the time of shipment for the **EH** Series. This is called "factory home position."

The mechanism limit (mechanical end) is stored in the ABZO sensor (fixed value) for products that the factory home position is set. If the moving part reaches the mechanism limit during operation, an alarm of mechanical overtravel is generated. The position of the mechanism limit does not change even if the home position is set by the customer side.

To disable the mechanism limit, change the "Mechanism limit parameter setting" parameter to "Disable."

However, if the mechanism limit is disabled, the moving parts may hit the stoppers inside the product, causing damage to the product. Operate with enough care.

The figure shows the factory home position and the mechanism limit with reference to the moving part (finger) on the left.

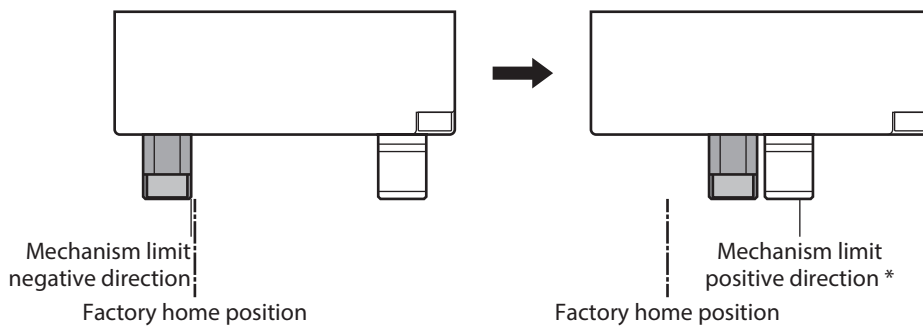

* The mechanism limit on the positive side is set outside the moving range.

CAUTION

When disabling the mechanism limit, be careful not to damage the product or equipment by thoroughly examining the operation data such as the travel amount (position) and the operating speed.



If the moving part reaches the mechanism limit on the negative direction and a state of generating the alarm of mechanical overtravel is continued, an alarm of overload may also be generated.

■ EH3-AZAKH



The operation data and parameters are set for one side of the moving parts (fingers).

● Product specifications

Item	Factory setting
Lead	9.425 [mm]
Minimum travel amount *1	0.01 [mm]
Mechanism limit positive direction *2	12.5 [mm] (1,250 step)
Mechanism limit negative direction *2	-0.5 [mm] (-50 step)

*1 The minimum travel amount is determined by the "Electronic gear" parameter and the lead.

*2 Distance from the factory home position.

● Upper limit value of setting



If a value exceeding the upper limit value is set to start operation, an alarm of operation data error is generated. The upper limit value can also be checked using the unit information monitor (mechanism protection parameter) of the **MEXE02** software.

Item	Factory setting	
	Unit of travel amount: mm	Unit of travel amount: step
Maximum starting speed	6.13 [mm/s]	613 [Hz]
Maximum operating speed	78.07 [mm/s]	7,807 [Hz]
Maximum pushing speed	10.05 [mm/s]	1,005 [Hz]
Maximum pushing return-to-home speed	10.05 [mm/s]	1,005 [Hz]
Maximum push current	100 [%] *	

* It is the upper limit value when push-motion return-to-home operation is performed. When push-motion operation is performed, check the upper limit value with the graph on p.14.

● Motor & mechanism parameters

Item	Factory setting	
	Unit of travel amount: mm	Unit of travel amount: step
Mechanism settings	Prioritize ABZO setting	Prioritize ABZO setting
Electronic gear A	400	400
Electronic gear B	377	377
Motor rotation direction	Positive side=Clockwise	Positive side=Clockwise
Mechanism lead	9,425	9,425
Mechanism lead decimal digit setting	×0.001 [mm]	×0.001 [mm]
JOG/HOME/ZHOME operation setting	Prioritize ABZO setting	Prioritize ABZO setting
(JOG) Operating speed	2.04 [mm/s]	204 [Hz]
(JOG) Acceleration/deceleration	0.70500 [m/s ²]	70.500 [kHz/s]
(JOG) Starting speed	0.63 [mm/s]	63 [Hz]
(JOG) Operating speed (high)	10.05 [mm/s]	1,005 [Hz]
(ZHOME) Operating speed	10.05 [mm/s]	1,005 [Hz]
(ZHOME) Acceleration/deceleration	0.52333 [m/s ²]	52.333 [kHz/s]
(ZHOME) Starting speed	0.63 [mm/s]	63 [Hz]
(HOME) Home-seeking mode	Push	Push
(HOME) Starting direction	Positive side	Positive side
(HOME) Acceleration/deceleration	0.50200 [m/s ²]	50.200 [kHz/s]
(HOME) Starting speed	5.03 [mm/s]	503 [Hz]
(HOME) Operating speed	10.05 [mm/s]	1,005 [Hz]

Item	Factory setting	
	Unit of travel amount: mm	Unit of travel amount: step
(HOME) Last speed	0.63 [mm/s]	63 [Hz]
(HOME) Backward steps in 2 sensor home-seeking	0.50 [mm]	50 [step]
(HOME) Operating amount in uni-directional home-seeking	0.50 [mm]	50 [step]
(HOME) Operating current for push-home-seeking	100 [%] *	100 [%] *
(HOME) Backward steps in push-home-seeking	7.6 [mm]	760 [step]

* When performing push-motion return-to-home operation, use the actuator with the operating current of the factory setting as much as possible. If the operating current smaller than the factory setting is set, the TLC output may be turned ON before push motion is complete, causing push-motion return-to-home operation to end at an unexpected position.

■ EH4-AZAKH



The operation data and parameters are set for one side of the moving parts (fingers).

● Product specifications

Item	Factory setting
Lead	9.425 [mm]
Minimum travel amount *1	0.01 [mm]
Mechanism limit positive direction *2	17.5 [mm] (1,750 step)
Mechanism limit negative direction *2	-0.5 [mm] (-50 step)

*1 The minimum travel amount is determined by the "Electronic gear" parameter and the lead.

*2 Distance from the factory home position.

● Upper limit value of setting



If a value exceeding the upper limit value is set to start operation, an alarm of operation data error is generated. The upper limit value can also be checked using the unit information monitor (mechanism protection parameter) of the **MEXE02** software.

Item	Factory setting	
	Unit of travel amount: mm	Unit of travel amount: step
Maximum starting speed	6.13 [mm/s]	613 [Hz]
Maximum operating speed	78.07 [mm/s]	7,807 [Hz]
Maximum pushing speed	10.05 [mm/s]	1,005 [Hz]
Maximum pushing return-to-home speed	10.05 [mm/s]	1,005 [Hz]
Maximum push current	100 [%] *	

* It is the upper limit value when push-motion return-to-home operation is performed. When push-motion operation is performed, check the upper limit value with the graph on p.14.

● Motor & mechanism parameters

Item	Factory setting	
	Unit of travel amount: mm	Unit of travel amount: step
Mechanism settings	Prioritize ABZO setting	Prioritize ABZO setting
Electronic gear A	400	400
Electronic gear B	377	377
Motor rotation direction	Positive side=Clockwise	Positive side=Clockwise
Mechanism lead	9,425	9,425
Mechanism lead decimal digit setting	×0.001 [mm]	×0.001 [mm]
JOG/HOME/ZHOME operation setting	Prioritize ABZO setting	Prioritize ABZO setting
(JOG) Operating speed	2.04 [mm/s]	204 [Hz]
(JOG) Acceleration/deceleration	0.70500 [m/s ²]	70.500 [kHz/s]
(JOG) Starting speed	0.63 [mm/s]	63 [Hz]
(JOG) Operating speed (high)	10.05 [mm/s]	1,005 [Hz]
(ZHOME) Operating speed	10.05 [mm/s]	1,005 [Hz]
(ZHOME) Acceleration/deceleration	0.52333 [m/s ²]	52.333 [kHz/s]
(ZHOME) Starting speed	0.63 [mm/s]	63 [Hz]
(HOME) Home-seeking mode	Push	Push
(HOME) Starting direction	Positive side	Positive side
(HOME) Acceleration/deceleration	0.50200 [m/s ²]	50.200 [kHz/s]
(HOME) Starting speed	5.03 [mm/s]	503 [Hz]
(HOME) Operating speed	10.05 [mm/s]	1,005 [Hz]

Item	Factory setting	
	Unit of travel amount: mm	Unit of travel amount: step
(HOME) Last speed	0.63 [mm/s]	63 [Hz]
(HOME) Backward steps in 2 sensor home-seeking	0.50 [mm]	50 [step]
(HOME) Operating amount in uni-directional home-seeking	0.50 [mm]	50 [step]
(HOME) Operating current for push-home-seeking	100 [%] *	100 [%] *
(HOME) Backward steps in push-home-seeking	12.55 [mm]	1,255 [step]

* When performing push-motion return-to-home operation, use the actuator with the operating current of the factory setting as much as possible. If the operating current smaller than the factory setting is set, the TLC output may be turned ON before push motion is complete, causing push-motion return-to-home operation to end at an unexpected position.

2-4 Operation

This chapter describes precautions when an actuator equipped with the **AZ** Series is operated. Refer to the **AZ** Series OPERATING MANUAL Function Edition for descriptions about operations.

■ Push-motion return-to-home operation

⚠ CAUTION

- Perform push-motion return-to-home operation within the specifications of the product. Failure to do so may result in injury or damage to equipment. Check on the Oriental Motor Website for the product specifications.
- When push-motion return-to-home operation is performed outward, provide a mechanism that the moving part press against within the stroke. Pressing against exceeding the range of the stroke may result in injury or damage to equipment.

● Actuator movement

Push-motion return-to-home operation is started, and when the moving parts (fingers) press against to turn the TLC output ON, they move in the reverse direction and then stop after moving according to the value set in the "(HOME) Backward steps after first entry in push-home-seeking" parameter. (factory setting: 0)

The moving parts (fingers) move in the reverse direction again, and when they press against to turn the TLC output ON, they move in the reverse direction once again and then stop after moving according to the value set in the "(HOME) Backward steps in push-home-seeking" parameter.

After that, they move according to the value set in the "(HOME) Position offset" parameter and stop. (factory setting: 0)

The figure next describes examples when an actuator is used with the factory setting.

1. Push-motion return-to-home operation starts.

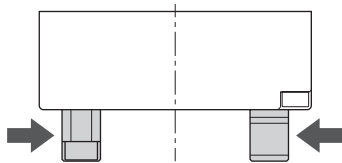

2. The moving parts (fingers) press against and the TLC output is turned ON.

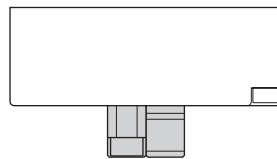

3. They move in the reverse direction and move according to the value set in the "(HOME) Backward steps after first entry in push-home-seeking" and stop.

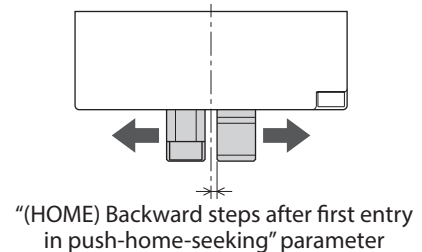

4. The moving parts (fingers) move in the reverse direction again to press against, and the TLC output is turned ON.

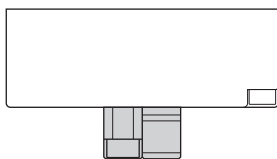

5. They reverse and stop after moving according to the value set in the "(HOME) Backward steps in push-home-seeking" parameter.

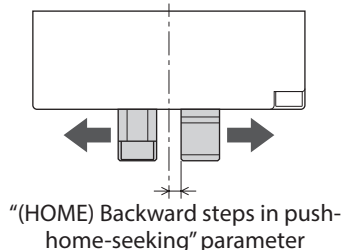

6. Again, they move according to the value set in the "(HOME) Position offset" and stop. (factory setting: 0)

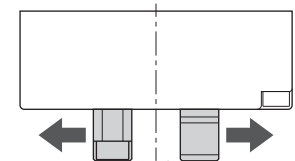

● Push force

The push force of push-motion return-to-home operation is proportional to the current value. An appropriate current value is set for each actuator at the time of shipment. When changing the push force, set a value with the "(HOME) Operating current for push-home-seeking" parameter.



The upper limit value can also be checked using the unit information monitor (mechanism protection parameter) of the **MEXE02** software.

● **Operating speed**

Set the operating speed of push-motion return-to-home operation to 10 mm/s or less.

■ **Push-motion operation**

The gripping movement of the **EH** Series is performed with push-motion operation.
Set the gripping force with the operating current.

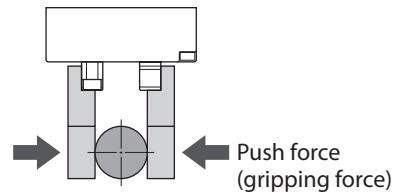

● **Specifications of push-motion operation**

Perform push-motion operation within the specifications shown below.

Model	Maximum push force (gripping force)	Maximum pushing speed
EH3	7 N	10 mm/s
EH4	25 N	

● **Relationship between the push force (gripping force) and current**

Reference values of the push force (gripping force) and current are shown next. Check the actual push force (gripping force) using the product.

Push force (gripping force) actual value [reference value]

● **EH3**

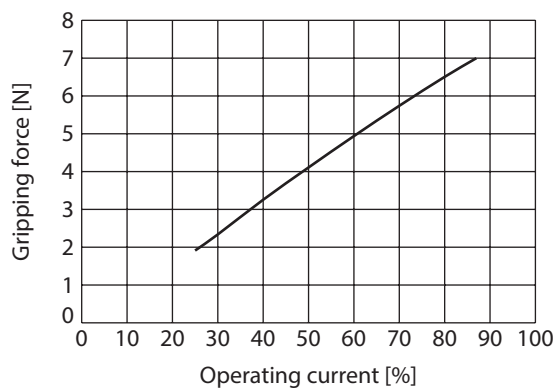

● **EH4**

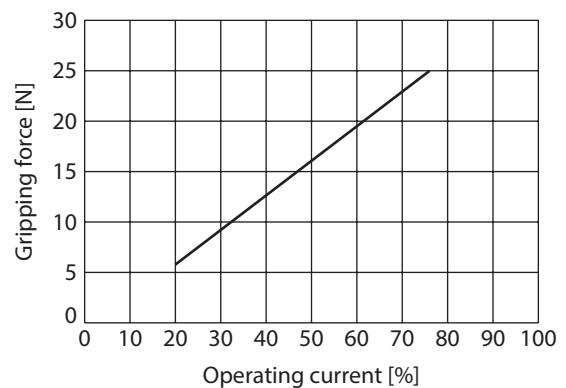

- The operation data and parameters are set for one side of the moving parts (fingers).
- The relationship between the push force (gripping force) and current varies depending on the following conditions. Check the actual push force (gripping force) using the product.
 - Installation condition of the actuator (horizontal direction installation, vertical direction installation)
 - Customer's load condition such as jig
 - Cable length
 - Ambient temperature

3 When using the EH Series 3-finger type

3-1 Traveling direction of the moving part

The travel direction of the moving part varies depending on the setting of the travel amount or the input method of pulse signals. Check on the following table.

The table below describes examples when an actuator is used with the factory setting.

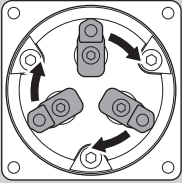
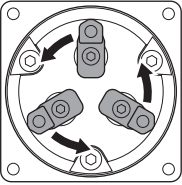
Setting	Traveling direction
When setting parameters to operate Set the travel amount to the positive (+) side.	Rotates in clockwise direction (CW) 
When operating using pulse signals <ul style="list-style-type: none"> • 2-pulse input mode Input the pulse signals to the CW input • 1-pulse input mode Input the pulse signal to the PLS input when the DIR input is ON 	
When setting parameters to operate Set the travel amount to the negative (-) side.	Rotates in counterclockwise direction (CCW) 
When operating using pulse signals <ul style="list-style-type: none"> • 2-pulse input mode Input the pulse signals to the CCW input • 1-pulse input mode Input the pulse signal to the PLS input when the DIR input is OFF 	

3-2 Setting of travel amount

memo Operation data and parameters are set for a single moving part (finger).

- **Setting with the absolute position**

Set the travel amount of the moving part (finger) with reference to the home.

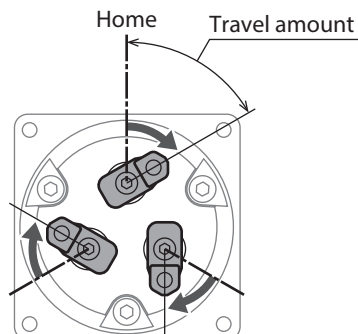

- **Setting with the relative position**

Set the travel amount of the moving part (finger) with reference to the present position.

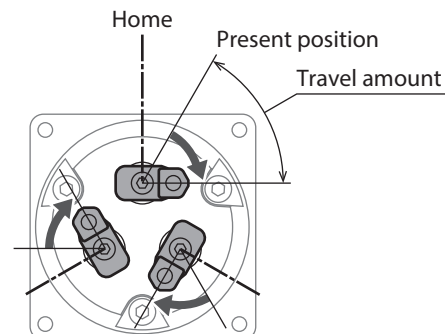

■ Setting example

The rotation angle of the fingers is not proportional to the pitch circle diameter. The travel amount varies depending on the position of the finger.



The attachment is not installed in this setting example. When installing the attachment, take into account the dimensions of the attachment and calculate the position in accordance with the formula.

● Setting Example 1: When changing the pitch circle diameter from 30 mm to 20 mm

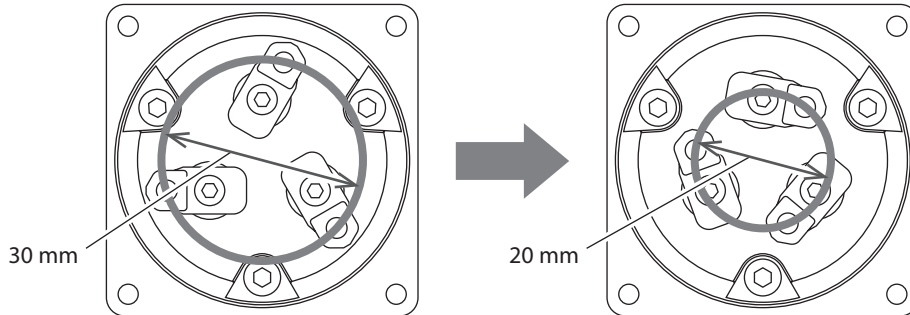

Setting of pitch circle diameter 30 mm

- Operation type: Absolute positioning
- Position: 391 step
- Others: Factory setting

Setting of pitch circle diameter 20 mm

- Operation type: Absolute positioning
- Position: 1,408 step
- Others: Factory setting

● Setting Example 2: When changing the pitch circle diameter from 20 mm to 10 mm

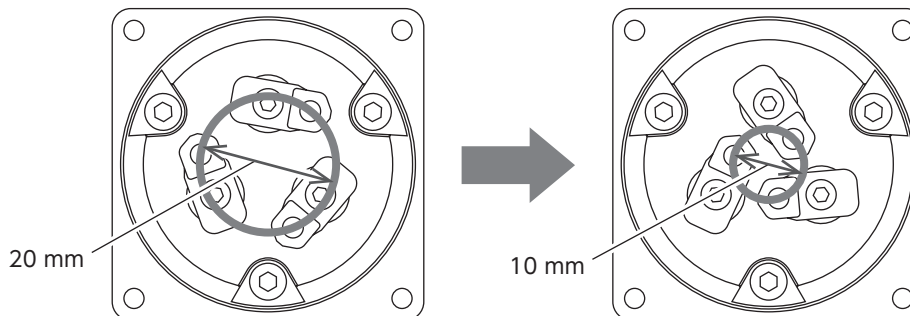

Setting of pitch circle diameter 20 mm

- Operation type: Absolute positioning
- Position: 1,408 step
- Others: Factory setting

Setting of pitch circle diameter 10 mm

- Operation type: Absolute positioning
- Position: 2,051 step
- Others: Factory setting

3-3 Setting of gripping force

Gripping force refers to the load that is generated in the direction of the center of the gripped object on the contact point between the attachment and the gripped object.

The gripping force can be adjusted with the operating current.

The gripping force of the 3-finger type gripper varies according to the diameter of the gripped object. Therefore, adjust the gripping force based on the size, mass, and strength of the gripped object. The gripping force can be calculated using the formula below.

$$F = \frac{0.174}{r \times 10^{-3}} \div \sin \left\{ \theta - \tan^{-1} \left(\frac{r \times \sin \theta}{9.05 + r \times \cos \theta} \right) \right\}$$

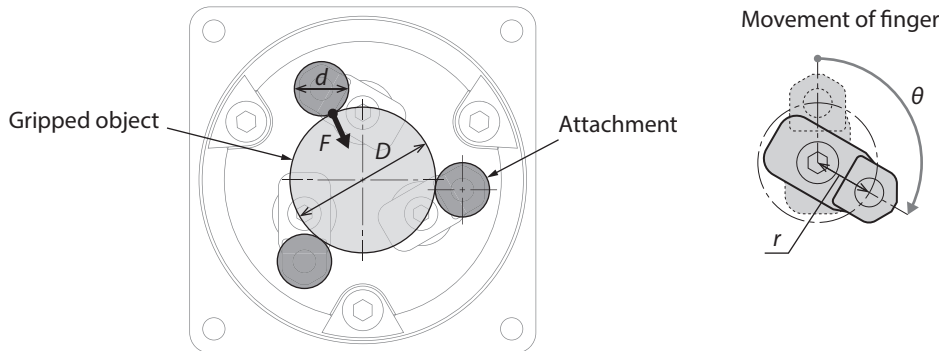

d : Diameter of attachment [mm]

D : Outer diameter (or inner diameter) of gripped object [mm]

F : Gripping force [N]

r : Rotation radius of attachment [mm] (=6.4)

θ : Rotation angle of finger [°]

- memo**
- The mass of a load that can actually be transported varies greatly depending on the attachment, the friction coefficient of a load, the acceleration rate and others. Use the gripper with one tenth of the gripping force as the upper limit and with a sufficient margin.
 - The gripping force may exceed the maximum gripping force depending on the design of the gripped object and the attachment. Use in a state of exceeding the maximum gripping force may damage the product. Adjust the operating current so that the actual gripping force is less than the maximum gripping force if it is exceeded. Check with the actual equipment by reference to the graph on p.21.

The relationship among D , d , r , and θ is as follows.

- When gripping the outer diameter of the object
- When gripping the inner diameter of the object

$$D = 2 \times \sqrt{(9.05 + r \times \cos \theta)^2 + (r \times \sin \theta)^2} - d$$

$$D = 2 \times \sqrt{(9.05 + r \times \cos \theta)^2 + (r \times \sin \theta)^2} + d$$

- memo**
- The travel amount and gripping force required to grip the object can also be calculated with the **MEXE02** software. It can be calculated by inputting information such as the attachment and gripped object with the "3-finger type target position calculation" function of the **MEXE02** software. If the "3-finger type target position calculation" tab is not shown, start it from the "Support" menu. Use the **MEXE02** software with a version number of 4.13.1.0 or higher.

3-4 Parameter list

The motorized actuator equipped with the AZ Series can be used with the parameters at the time of shipment.



- Check the specifications of the maximum speed to set the operating speed.
- The operating speed may not reach the maximum speed depending on the ambient temperature, the travel amount of the finger, or the length of the cable for motor.
- When using in combination with the pulse input type driver:
Use the function setting switch No.1 (resolution setting) with the factory setting as it is. If it is changed, the ABZO information does not apply and the actuator will operate at a certain resolution.

■ How to read the table

This section describes parameters that have set a value specific to the motorized actuator. Setting the specified values allows operation that satisfies the specifications of the motorized actuator.

■ EH4T-AZAK, EH4T-AZAKH



Operation data and parameters are set for a single moving part (finger).

● Upper limit value of setting



If a value exceeding the upper limit value is set to start operation, an alarm of operation data error is generated. The upper limit value can also be checked using the unit information monitor (mechanism protection parameter) of the **MEXE02** software.

Item	Factory setting
Maximum starting speed	100,000 [Hz]
Maximum operating speed	100,000 [Hz]
Maximum pushing speed	1,000 [Hz]
Maximum pushing return-to-home speed	1,000 [Hz]
Maximum push current	100 [%]*

* It is the upper limit value when push-motion return-to-home operation is performed. When push-motion operation is performed, check the upper limit value with the graph on p.21.

● Motor & mechanism parameter

Item	Factory setting
Mechanism settings	Prioritize ABZO setting
Electronic gear A	1
Electronic gear B	1
Motor rotation direction *1	Positive direction=CCW
Mechanism type	Step
JOG/HOME/ZHOME operation setting	Prioritize ABZO setting
(JOG) Operating speed	500 [Hz]
(JOG) Acceleration/deceleration	50 [kHz/s]
(JOG) Starting speed	250 [Hz]
(JOG) Operating speed (high)	1,000 [Hz]
(ZHOME) Operating speed	1,000 [Hz]
(ZHOME) Acceleration/deceleration	50 [kHz/s]
(ZHOME) Starting speed	500 [Hz]

Item	Factory setting
(HOME) Home-seeking mode	Push-motion
(HOME) Starting direction	Positive side*2
(HOME) Acceleration/deceleration	50 [kHz/s]
(HOME) Starting speed	500 [Hz]
(HOME) Operating speed	1,000 [Hz]
(HOME) Last speed	500 [Hz]
(HOME) Operating current for push-home-seeking	100 [%]*3
(HOME) Backward steps in push-home-seeking	2,260 [step]*4

*1 A value different from the initial value of the motor by itself is written to the ABZO sensor.

*2 The fingers start return-to-home operation to the positive side (CW).

*3 When performing push-motion return-to-home operation, use the product at the operating current of the factory setting as much as possible. If the operating current smaller than the factory setting is set, the TLC output may be turned ON before pushing is completed, causing push-motion return-to-home operation to end at an unexpected position.

*4 It returns to the position where the pitch circle diameter is largest (P.C.D. $\phi 30.9$ mm).

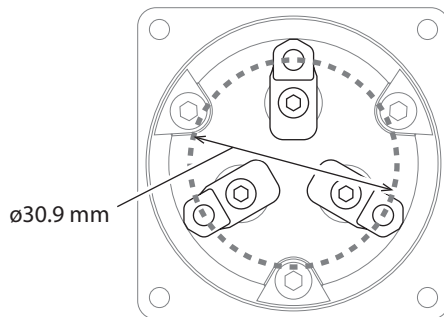

3-5 Operation

CAUTION

Perform push-motion return-to-home operation within the specifications of the product. Failure to do so may result in injury or damage to equipment. Check on the Oriental Motor Website for the product specifications.

■ Push-motion return-to-home operation

● Operation

Push-motion return-to-home operation is started, and when the moving parts (fingers) press against to turn the TLC output ON, they move in the reverse direction. And they stop after moving according to the value set in the "(HOME) Backward steps after first entry in push-home-seeking" parameter. (Factory setting: 0)

The moving parts (fingers) move in the reverse direction again, and when they press against to turn the TLC output ON, they move in the reverse direction once again. And they stop after moving according to the value set in the "(HOME) Backward steps in push-home-seeking" parameter. (Factory setting: 2,260 steps)

The figures describe examples when an actuator is used with the factory setting.

1. Push-motion return-to-home operation is started. (Rotates in the positive direction)

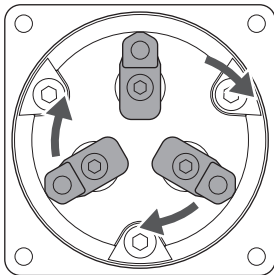

2. The moving parts (fingers) press against to turn the TLC output ON.

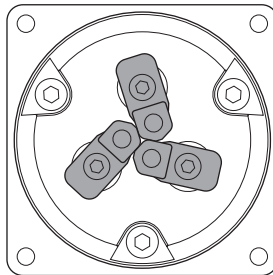

3. The moving parts (fingers) reverse, and stop after moving according to the value set in the "(HOME) Backward steps after first entry in push-home-seeking." (Factory setting: 0)

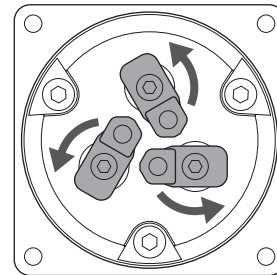

4. The moving parts (fingers) reverse again, and press against to turn the TLC output ON.

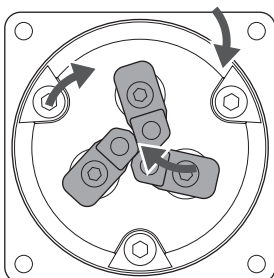

5. The moving parts (fingers) reverse, and stop after moving according to the value set in the "(HOME) Backward steps in push-home-seeking." (Factory setting: 2,260 steps)

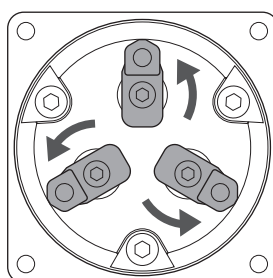

6. And the moving parts (fingers) move according to the value set in the "(HOME) Position offset" and stop. (Factory setting: 0)

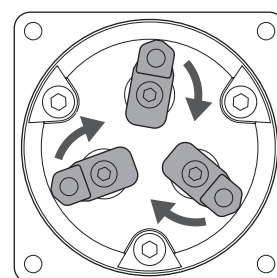

● Push force

The push force of push-motion return-to-home operation is proportional to the current value. An appropriate current value is set for each actuator at the time of shipment. When changing the push force, set a value with the "(HOME) Operating current for push-home-seeking" parameter.



The upper limit value can also be checked using the unit information monitor (mechanism protection parameter) of the **MEXE02** software.

● **Operating speed**

Set the operating speed of push-motion return-to-home operation to 1,000 Hz or less.



If an electronic gear is changed, the rotation speed of the finger is changed. When changing an electronic gear from the factory setting, set the rotation speed of the finger to 12 r/min or less.

■ **Push-motion operation**

The gripping movement of the EH Series is performed with push-motion operation.
Set the push force (gripping force) with the operating current.

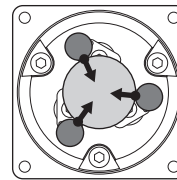

↑ Push force (gripping force)

● **Specifications of push-motion operation**

Perform push-motion operation within the specifications shown below.

Maximum push force (gripping force)	50 N
Maximum pushing speed	1,000 Hz



If an electronic gear is changed, the rotation speed of the finger is changed. When changing an electronic gear from the factory setting, set the rotation speed of the finger to 12 r/min or less.

● **Relationship between diameters of gripped object /attachment and push force (gripping force) [reference value]**

The reference value between the sum of the diameters of the gripped object and attachment and the push force (grasping force) is shown below. Check the actual push force (gripping force) with the actual equipment.

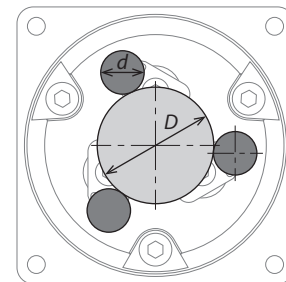
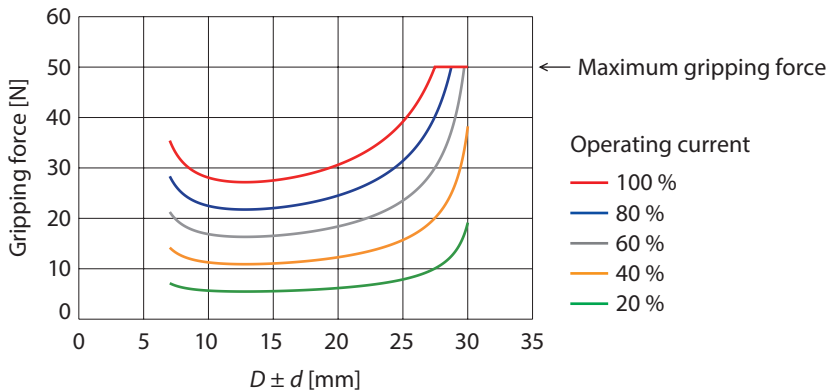

D : Outer diameter (or inner diameter) of the gripped object [mm]
 d : Diameter of attachment [mm]

$D + d$: Grasp the outer diameter of the object

$D - d$: Grasp the inner diameter of the object



- Operation data and parameters are set for a single moving part (finger).
- The gripping force may exceed the maximum gripping force depending on the design of the gripped object and the attachment. Use in a state of exceeding the maximum gripping force may damage the product. If the maximum gripping force is exceeded, adjust the operating current so that the actual gripping force is less than the maximum gripping force. Check with the actual equipment by reference to the graph.
- The relationship between the push force (gripping force) and the current varies depending on the following conditions. Check the actual push force (gripping force) with the actual equipment.
 - Mounting direction of actuator (horizontal direction, vertical direction)
 - Load such as customer's jig
 - Cable length
 - Ambient temperature

- Unauthorized reproduction or copying of all or part of this Manual is prohibited.
If a new copy is required to replace an original manual that has been damaged or lost, please contact your nearest Oriental Motor sales office.
- Oriental Motor shall not be liable whatsoever for any problems relating to industrial property rights arising from use of any information, circuit, equipment or device provided or referenced in this manual.
- Characteristics, specifications and dimensions are subject to change without notice.
- While we make every effort to offer accurate information in the manual, we welcome your input. Should you find unclear descriptions, errors or omissions, please contact your nearest Oriental Motor sales office.
- **Orientalmotor** and ABZO sensor are registered trademarks or trademarks of Oriental Motor Co., Ltd., in Japan and other countries.

Other product names and company names mentioned in this manual may be registered trademarks or trademarks of their respective companies and are hereby acknowledged. The third-party products mentioned in this manual are recommended products, and references to their names shall not be construed as any form of performance guarantee. Oriental Motor is not liable whatsoever for the performance of these third-party products.

© Copyright ORIENTAL MOTOR CO., LTD. 2019

Published in March 2023

- Please contact your nearest Oriental Motor office for further information.

ORIENTAL MOTOR U.S.A. CORP.
Technical Support Tel:800-468-3982
8:30am EST to 5:00pm PST (M-F)
www.orientalmotor.com

ORIENTAL MOTOR (EUROPA) GmbH
Schiesstraße 44, 40549 Düsseldorf, Germany
Technical Support Tel:00 800/22 55 66 22
www.orientalmotor.de

ORIENTAL MOTOR (UK) LTD.
Unit 5 Faraday Office Park, Rankine Road,
Basingstoke, Hampshire RG24 8QB UK
Tel:+44-1256347090
www.oriental-motor.co.uk

ORIENTAL MOTOR (FRANCE) SARL
Tel:+33-1 47 86 97 50
www.orientalmotor.fr

ORIENTAL MOTOR ITALIA s.r.l.
Tel:+39-02-93906347
www.orientalmotor.it

ORIENTAL MOTOR ASIA PACIFIC PTE. LTD.
Singapore
Tel:1800-842-0280
www.orientalmotor.com.sg

ORIENTAL MOTOR (MALAYSIA) SDN. BHD.
Tel:1800-806-161
www.orientalmotor.com.my

ORIENTAL MOTOR (THAILAND) CO., LTD.
Tel:1800-888-881
www.orientalmotor.co.th

ORIENTAL MOTOR (INDIA) PVT. LTD.
Tel:1800-120-1995 (For English)
1800-121-4149 (For Hindi)
www.orientalmotor.co.in

TAIWAN ORIENTAL MOTOR CO., LTD.
Tel:0800-060708
www.orientalmotor.com.tw

SHANGHAI ORIENTAL MOTOR CO., LTD.
Tel:400-820-6516
www.orientalmotor.com.cn

INA ORIENTAL MOTOR CO., LTD.
Korea
Tel:080-777-2042
www.inaom.co.kr

ORIENTAL MOTOR CO., LTD.
4-8-1 Higashiueno, Taito-ku, Tokyo
110-8536 Japan
Tel:+81-3-6744-0361
www.orientalmotor.co.jp