

Compact Motorized Cylinder

DR Series Rod type

OPERATING MANUAL Actuator Edition

Table of contents

1	Introduction	2	7	Inspection and maintenance ...	44
2	Safety precautions	4	8	Troubleshooting	47
3	Precautions for use.....	7	9	Specifications	48
4	Preparation	12	10	Regulations and standards.....	51
5	Installation	16			
6	Connection	42			

Thank you for purchasing an Oriental Motor product.
This Manual describes product handling procedures and safety precautions.

- Please read it thoroughly to ensure safe operation.
- Always keep the manual where it is readily available.

1 Introduction

1-1 Before use

Only qualified personnel of electrical and mechanical engineering should work with the product.

Use the product correctly after thoroughly reading the section "2 Safety precautions" on p.4. In addition, be sure to observe the contents described in warning, caution, and note in this manual.

The product described in this manual is designed and manufactured to be incorporated in general industrial equipment. Do not use for any other purpose. Oriental Motor Co., Ltd. is not responsible for any compensation for damage caused through failure to observe this warning.

1-2 Overview of the product

The compact motorized cylinder **DR Series** (hereinafter described as cylinder) is an actuator of a linear motion mechanism that a stepping motor is integrated with a ball screw.

The following two types of motors are provided.

- 2-Phase Stepping Motor **PKP Series**
- Stepping Motor **αSTEP AZ Series**

1-3 Related operating manuals

For operating manuals, download from Oriental Motor Website Download Page or contact your nearest Oriental Motor sales office.

■ Cylinder equipped with the PKP Series

- **DR Series OPERATING MANUAL Actuator Edition**
(this document)
- Motorized actuator Compact Motorized Cylinder
Function Setting Edition *

* Be sure to read the operating manual "Function Setting Edition" which is exclusively for compact motorized cylinders.

Refer to the operating manual of the driver for contents not described in these manuals.

■ Cylinder equipped with the **AZ** Series

- **DR** Series OPERATING MANUAL Actuator Edition (this document)
- **AZ** Series/Motorized actuator equipped with **AZ** Series OPERATING MANUAL Function Edition
- Motorized actuator Compact Motorized Cylinder Function Setting Edition *

* Be sure to read the operating manual "Function Setting Edition" which is exclusively for compact motorized cylinders.

Refer to the operating manual of the driver for contents not described in these manuals.



2 Safety precautions

The precautions described below are intended to ensure the safe and correct use of the product, and to prevent the customer and others from exposure to the risk of injury. Use the product only after carefully reading and fully understanding these instructions.



You must not operate the cylinder (operate the equipment for the specified purpose) if the machine in which the cylinder is installed does not satisfy the related safety standards. The factory safety manager or safety personnel in charge of the applicable machine must ensure that the machine is operated only by qualified personnel who are familiar with the operation of electronic equipment, and thereby prevent injury or damage to the equipment.

The term "qualified personnel" refers to persons who have received the necessary training or education and have pertinent experience; who are familiar with the relevant standards, regulations, accident-prevention rules and inspection conditions; who are authorized by the factory safety manager to engage in the necessary activities; and who have the ability to discern and prevent potential dangers.

Description of signs

 WARNING	Handling the product without observing the instructions that accompany a "WARNING" symbol may result in serious injury or death.
 CAUTION	Handling the product without observing the instructions that accompany a "CAUTION" symbol may result in injury or property damage.
 Note	The items under this heading contain important handling instructions that the user should observe to ensure the safe use of the product.

Description of graphic symbols

	Indicates "prohibited" actions that must not be performed.
	Indicates "compulsory" actions that must be performed.

WARNING





- Do not use the cylinder in explosive or corrosive environments, in the presence of flammable gases, in places subjected to splashing water, or near combustibles. Doing so may result in fire or injury.
- Do not transport, install, connect or inspect the cylinder while the power is supplied. Doing so may result in electric shock.
- Do not forcibly bend, pull or pinch the cable. Doing so may result in fire.
- Do not disassemble or modify the cylinder. Doing so may result in injury or damage to equipment.
- Never use the cylinder in a medical device used in connection with the maintenance or management of human life or health, or in a transportation system whose purpose is to move or carry people.
- Be sure to provide a safety cage conforming to EN ISO 13857 to prevent persons from entering the moving range of the cylinder while power is supplied to the cylinder. Turn off the main power to the driver before performing adjustment or inspection in which the moving part is moved manually. Failure to do so may result in injury.
- Do not hit the ball screw with the mechanical stopper in operations other than push-motion operation. Doing so may result in injury or damage to equipment.



- Assign qualified personnel to the task of installing, wiring, operating/controlling, inspecting and troubleshooting the cylinder. Handling by unqualified personnel may result in fire, injury, or damage to equipment.
- When setting the data, do so outside the safety cage. Failure to do so may result in injury.
- Take measures to keep the moving part in position if the cylinder is used in vertical operations such as elevating equipment. Failure to do so may result in injury or damage to equipment.
- When an alarm is generated in the driver (any of the driver's protective functions is triggered), take measures to hold the moving part in a specific position since the cylinder stops and loses its holding torque. Failure to do so may result in injury or damage to equipment.
- Install the cylinder inside an enclosure. Failure to do so may result in injury.
- Operate the cylinder after setting the home. Operating the cylinder without setting the home may cause unexpected movements, leading to injury or damage to equipment.
- Provide an emergency stop device or emergency stop circuit external to the equipment so that the entire equipment will operate safely in the event of a system failure or malfunction. Failure to do so may result in injury.
- After replacing the driver, set the resolution, traveling direction or other parameters before operating the cylinder. If the cylinder is operated without setting parameters, the ball screw may move to unexpected directions or run at unexpected speeds, causing injury or damage to equipment.

CAUTION

	<ul style="list-style-type: none">• Do not use the cylinder beyond its specifications. Doing so may result in injury or damage to equipment.• Keep your fingers and objects out of the openings in the cylinder. Failure to do so may result in fire or injury.• Do not touch the cylinder during operation or immediately after stopping. Doing so may result in a skin burn(s).• Do not carry the cylinder by holding the moving part or cable. Doing so may cause injury.• Keep the area around the cylinder free of combustible materials. Failure to do so may result in fire or a skin burn(s).• Do not leave anything around the cylinder that would obstruct ventilation. Doing so may result in damage to equipment.• Do not touch the moving part during operation. Doing so may result in injury.• Do not touch the terminals while conducting the insulation resistance measurement or dielectric strength test. Doing so may result in electric shock.• While the cylinder is operated, do not make the cable contact with the moving part. Doing so may result in disconnection in the cable, leading to damage.
	<ul style="list-style-type: none">• Use the cylinder and driver only in the specified combination. Failure to do so may result in fire.• Wear a helmet, safety shoes, gloves or other protective gear when transporting or installing the cylinder. Failure to do so may result in injury.• The motor surface temperature may exceed 70 °C (158 °F) even under normal operating conditions. If the operator is allowed to approach the cylinder in operation, affix a warning label shown in the figure on a conspicuous position. Failure to do so may result in a skin burn(s).  <p>Warning label</p>

3 Precautions for use

This chapter covers restrictions and requirements the user should consider when using the product.

■ General

- **Be sure to use our cable to connect the cylinder and driver.**

Check on the Oriental Motor Website for the model name of cables.

- **Be sure to provide an anti-spin mechanism.**

The cylinder cannot be operated without an anti-spin mechanism because the ball screw rotates idly.

- **Do not remove the stopper attached to the ball screw.**

Doing so may result in damage to the ball screw.

- **When conducting the insulation resistance measurement or the dielectric strength test, be sure to separate the connection between the cylinder and the driver.**

Conducting the insulation resistance measurement or dielectric strength test with the cylinder and driver connected may result in damage to the product.

- **Do not make an impact on the cylinder.**

Do not drop the cylinder. Also, do not hit or strike the cylinder. Making an impact on the cylinder may cause the positioning accuracy to decrease, the cylinder to damage, or the lifetime to decrease.

- **Be sure to perform the center alignment for the shaft center of the ball screw and the traveling direction of a load.**

Failure to perform the center alignment may cause the positioning accuracy to decrease, the cylinder to damage, or the product life to shorten.

- **For cylinder with adjusting knob**

Use the adjusting knob to adjust the position manually while the power is turned off. Rotating the adjusting knob by one revolution moves by a lead amount of the ball screw. Adjust the position within the effective stroke range of the cylinder. Do not touch the adjusting knob during operation. Doing so may cause the cylinder to malfunction or damage.

■ Temperature

- **Use the cylinder equipped with the PKP Series in conditions where the motor surface temperature does not exceed 90 °C (194 °F).**

The motor does not have a function to protect from overheating. The motor surface temperature may exceed 90 °C (194 °F) under certain conditions (ambient temperature, operating speed, duty cycle, etc.). In order to prevent the bearings (ball bearings) of the motor from reaching its usable life quickly, use the cylinder in conditions where the motor surface temperature does not exceed 90 °C (194 °F).

- **Use the cylinder equipped with the AZ Series in conditions where the motor surface temperature does not exceed 80 °C (176 °F).**

The motor surface temperature may exceed 80 °C (176 °F) under certain conditions (ambient temperature, operating speed, duty cycle, etc.). In order to protect the encoder (ABZO sensor), use the cylinder in conditions where the motor surface temperature does not exceed 80 °C (176 °F).

If the encoder (ABZO sensor) temperature reaches the upper limit, the motor overheat protection alarm will generate.

- **Operate the cylinder in the range of the operating ambient temperature.**

If the cylinder is used outside of the operating ambient temperature, it may not operate properly.

■ Operation

- **Set the wiring distance between the cylinder and driver to less than the specification value.**

Set to 10 m (32.8 ft.) or less for the cylinder equipped with the **PKP** Series and to 20 m (65.6 ft.) or less for the cylinder equipped with the **AZ** Series. Exceeding the specification value may cause the thrust to decrease.

- **Holding torque at standstill**

The holding force at standstill for the cylinder is a value when the current cutback function (stop current 50 %) is enabled. Note the holding force is reduced in the current cutback state. In addition, turning off the power supply causes the holding force of the cylinder to lose. Make sure a load does not fall.

- **With the cylinder equipped with the AZ Series, do not perform push-motion operation at the speed exceeding the maximum push speed or the maximum push-motion return-to-home speed.**

The mechanical impact may cause damage to the cylinder. If the ball screw was pressed at high speed, take measures by referring to "8 Troubleshooting" on p.47.

- **Push-motion operation can be performed with the DR28 cylinder of ball screw lead 2.5 mm equipped with the AZ Series**

Do not perform push-motion operation with the cylinder of ball screw lead 1 mm equipped with the **AZ** Series. The TLC output may be turned ON before push-motion operation is complete. (Push-motion return-to-home operation can be performed.)

■ Inspection

● Grease

Grease on the ball screw may darken during the initial operation (one to three weeks). Refer to p.45, and wipe off the dirty grease to apply new grease.

● Abnormal noise

If an abnormal noise (i.e., from deflection or interference) is generated while operating cylinder, the installation accuracy may have dropped. Stop the operation and check the installation accuracy of the ball screw.

3-1 Note about using the cylinder equipped with the AZ Series

● Make sure not to hit or apply a strong impact on the encoder (ABZO sensor).

- Making a strong impact on an encoder (ABZO sensor) may cause the cylinder malfunction or damage to the encoder (ABZO sensor).
- When transporting the cylinder or installing a load, handle the cylinder carefully not to make a strong impact on the moving part.
- The warning label shown in the figure is indicated on the cylinder.

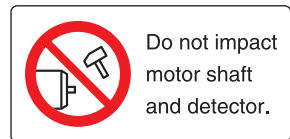

Warning label

● Do not move the encoder (ABZO sensor) toward a strong magnetic field.

A magnetic sensor is built into the encoder (ABZO sensor). If the cylinder is installed close to equipment which generates a strong magnetic field, the encoder (ABZO sensor) may break or malfunction. Make sure the environment at transportation and storage as well as the installation location in use. Keep the magnetic flux density on the surface of the encoder (ABZO sensor) so as not to exceed the values in the table.

	When transporting and storing	When operating
Magnetic flux density	5 mT	2 mT *

* When the magnetic flux density is exceeding 1 mT and 2 mT or less, use in an environment where the operating ambient temperature is exceeding 20 °C (68 °F) and 40 °C (104 °F) or less.

● Meshing noise of mechanical sensor

A gear type mechanical sensor is built into the encoder (ABZO sensor). Although the meshing noise of gears may generate, it is not malfunction.

Note the following points when our cable is used.

■ Cylinder equipped with the PKP Series

● When inserting the connector

Hold the connector main body, and insert it in straight securely. Inserting the connector in an inclined state may result in damage to connector or a connection failure.

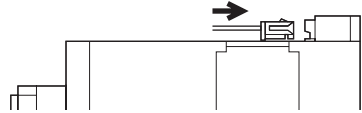

● When pulling out the connector

Pull out the connector in straight. Pulling out the connector with holding the lead wire may result in damage to the connector.

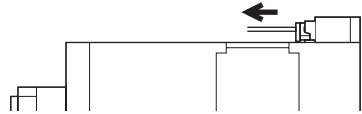

Fix the lead wires at the connection part of the connector to prevent the connector or terminals from receiving stress due to the bending or self-weight of the lead wires. Also, do not excessively bend the lead wires near the connection part of the connector. Applying stress on the lead wires may cause poor contact or disconnection, leading to malfunction or heat generation.

■ Cylinder equipped with the AZ Series

● When inserting the connector

Hold the connector main body, and insert it in straight securely. Inserting the connector in an inclined state may result in damage to terminals or a connection failure.

● When pulling out the connector

Pull out the connector in straight while releasing the lock part of the connector. Pulling out the connector with holding the cable may result in damage to the connector.

● Bending radius of cable

Use the cable in a state where the bending radius of the cable is more than six times of the cable diameter. Do not bend the lead wires part or fix it with a clamp. Doing so may cause damage to the connector.

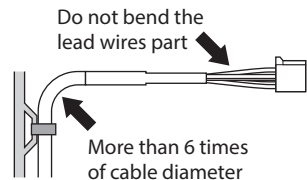

- **How to fix the cable**

Fix the cable near the connectors at two places as shown in the figure or fix it with a wide clamp to take measures to prevent stress from being applied to the connectors.

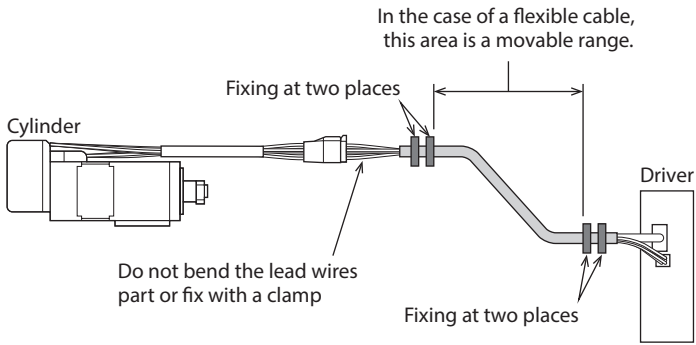

4 Preparation

4-1 Checking the product

Verify that the items listed below are included. Report any missing or damaged items to the Oriental Motor sales office from which you purchased the product.

- Compact motorized cylinder 1 unit
- Instructions and Precautions for Safe Use..... 1 copy

4-2 How to identify the product model

Verify the model name of the purchased against the number shown on the nameplate.

DR **28** **R** **2.5** **BC** **03** - **P2** **A** **K** **R** **-P**
 1 2 3 4 5 6 7 8 9 10 11

1	Series	DR: DR Series
2	Frame size	20: 20 mm 28: 28 mm
3	Type	R: Rod type
4	Ball screw lead	1: 1 mm 2.5: 2.5 mm
5	Ball screw type	A: Rolled ball screw AC: Rolled ball screw with cover B: Precision ball screw BC: Precision ball screw with cover
6	Stroke	02: 25 mm 03: 30 mm
7	Equipped motor	P2: PKP Series AZ: AZ Series
8	Additional function	A: None N: With adjusting knob
9	Motor power supply type	K: DC power supply input
10	Cable outlet direction *	U: Upward direction D: Downward direction R: Right direction L: Left direction
11	Foot	Blank: Without foot -P: With foot

* The cable outlet direction represents the direction as viewed from the opposite side of the ball screw in a state of placing the side face mounting sections downward.

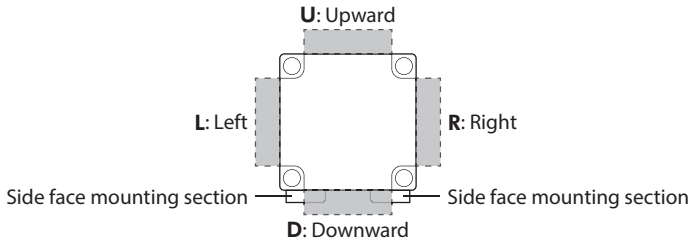

4-3 Information about nameplate

The figure shows an example.



4-4 Names of parts

The areas indicated in gray color represent a moving part.

■ Cylinder equipped with the PKP Series

The figure shows the DR28 with adjusting knob.

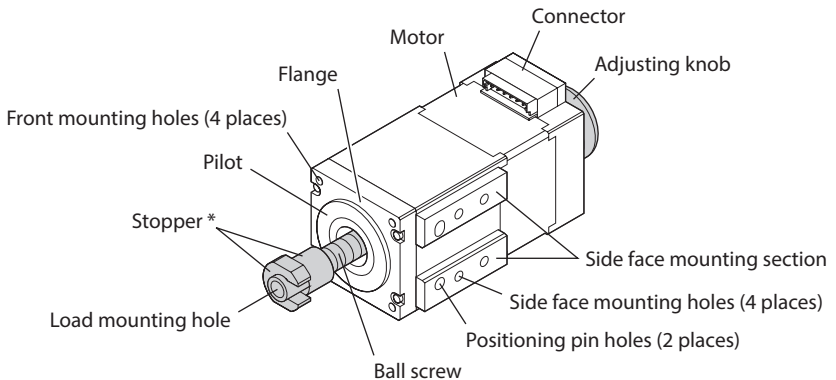

* This prevents the ball screw from retracting completely into the motor.

■ Cylinder equipped with the AZ Series

The figure shows the **DR20**.

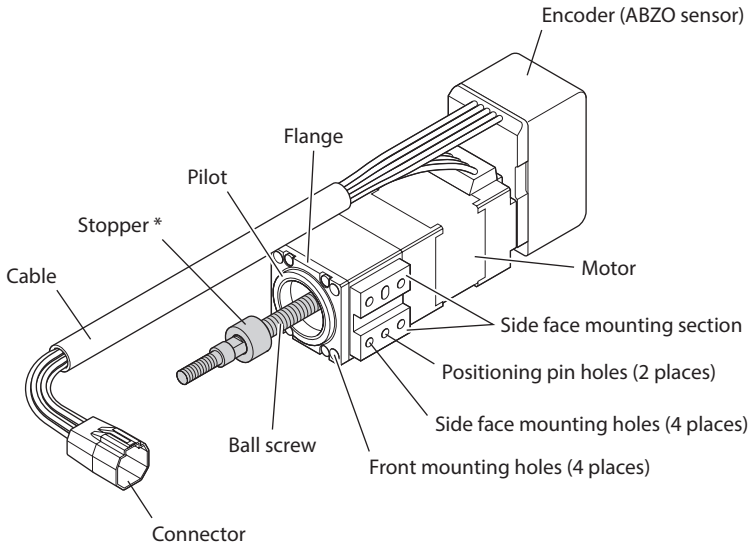

* This prevents the ball screw from retracting completely into the motor.

The figure shows the **DR28** with ball screw cover.

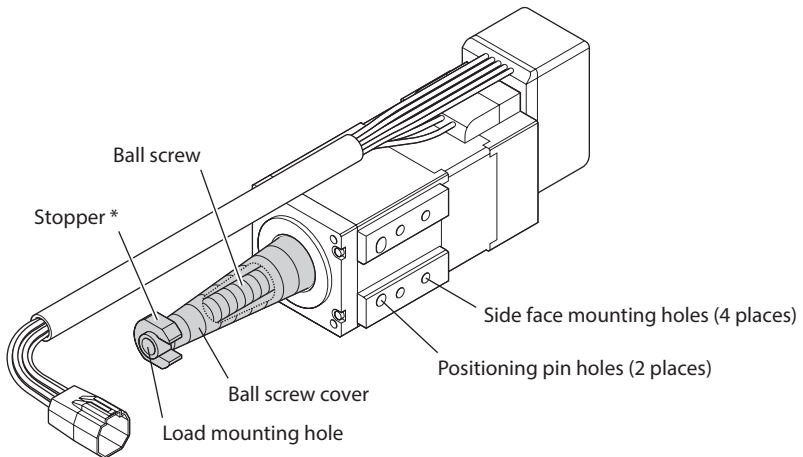

* This prevents the ball screw from retracting completely into the motor.

■ With foot

The figure shows the **DR28** equipped with the **PKP** Series.

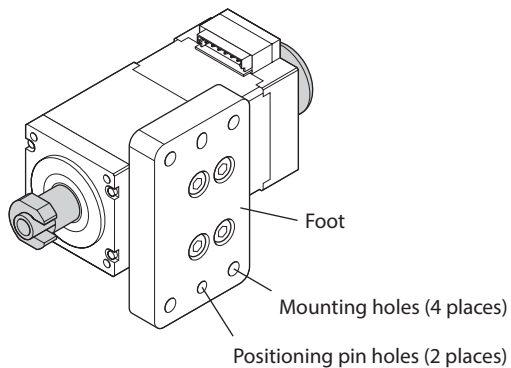

4-5 Driver for possible combinations

Use the **DR** Series in combination with the drivers shown in the table.

Equipped motor	Driver combination
PKP Series	CVD215BR-K, CVD215B-K, CVD215-K
AZ Series	DC power input driver

5 Installation

5-1 Installation location

The cylinder is designed and manufactured to be incorporated in equipment. Install it in a well-ventilated location that provides easy access for inspection. The location must also satisfy the following conditions:

- Inside an enclosure that is installed indoors (provide vent holes)
- Operating ambient temperature: 0 to +40 °C [+32 to +104 °F] (non-freezing)
- Operating ambient humidity: 85 % or less (non-condensing)
- Area free of explosive atmosphere or toxic gas (such as sulfuric gas) or liquid
- Area not exposed to direct sun
- Area free of excessive amount of dust, iron particles or the like
- Area not subject to splashing water (rain, water droplets), oil (oil droplets) or other liquids
- Area free of excessive salt
- Area not subject to continuous vibrations or excessive shocks
- Area free of excessive electromagnetic noise (from welders, power machinery, etc.)
- Area free of radioactive materials, magnetic fields or vacuum
- Up to 1,000 m (3,300 ft.) above sea level

5-2 Note when the cylinder equipped with the AZ Series is installed

■ If the cylinder is installed in an environment where a magnetic field is generated

A magnetic sensor is built into the encoder (ABZO sensor). If the cylinder is installed close to equipment which generates a strong magnetic field, the encoder (ABZO sensor) may break or malfunction. Keep the magnetic flux density on the surface of the encoder (ABZO sensor) so as not to exceed 2 mT*.

* When the magnetic flux density is exceeding 1 mT and 2 mT or less, use in an environment where the operating ambient temperature is exceeding 20 °C (68 °F) and 40 °C (104 °F) or less.



Do not install the cylinder close to equipment which generates a strong magnetic field.

■ Installing the cylinder equipped with the AZ Series

The encoder (ABZO sensor) of the cylinder equipped with the **AZ** Series is easily affected by a magnetic field, so make sure the installation location.

When cylinders are installed side by side, ensure the distance among cylinders of more than the frame size in horizontal and vertical directions.

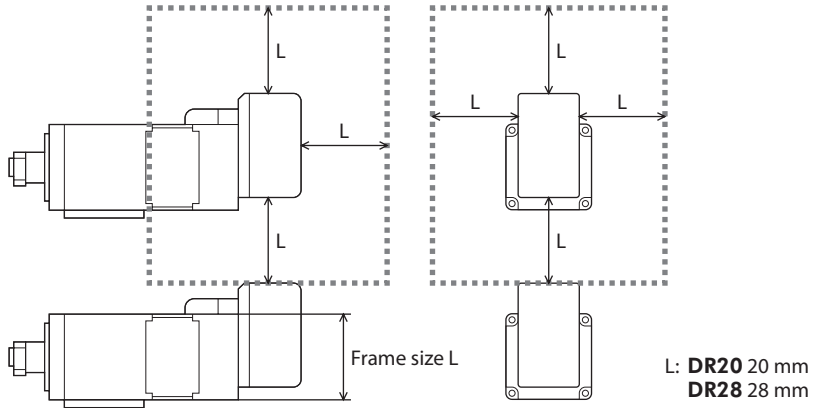

5-3 Installation overview

The cylinder cannot be operated without an anti-spin mechanism for the ball screw because the ball screw rotates idly. Be sure to provide the anti-spin mechanism such as a guide rail or movable plate by the customer.

Values of the tightening torque are recommended. Tighten with an appropriate torque according to the design conditions of the mounting plate, base plate, and load.

There are three installation methods, front mounting, side face mounting, and mounting using the foot.

■ Front mounting

Secure the cylinder to a mounting plate. The figure shows the **DR28**.

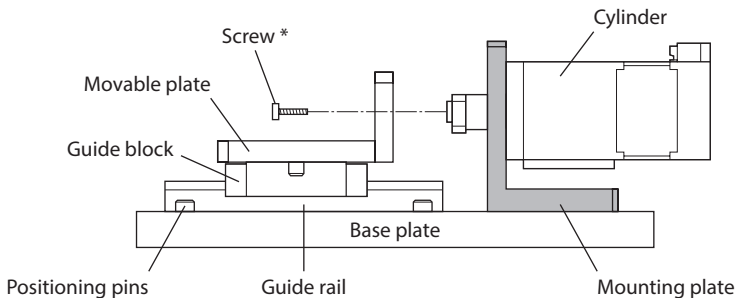

* Nut for **DR20**

■ Side face mounting

Secure the cylinder to a base plate using the side face mounting sections. The figure shows the **DR28**.

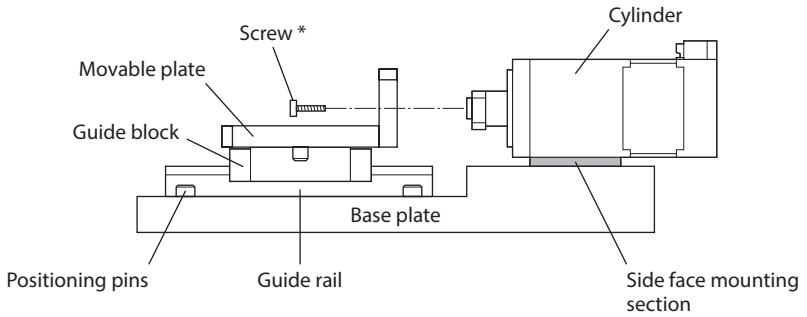

* Nut for **DR20**

■ Mounting using foot

Secure the cylinder to a base plate using the foot. The figure shows the **DR28**.

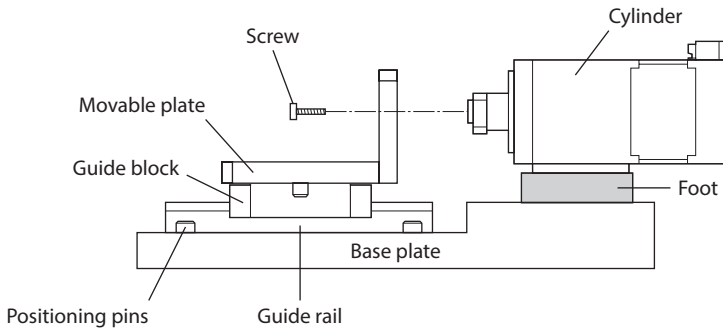

5-4 Process of installation

Install the cylinder according to the following process.

■ For front mounting

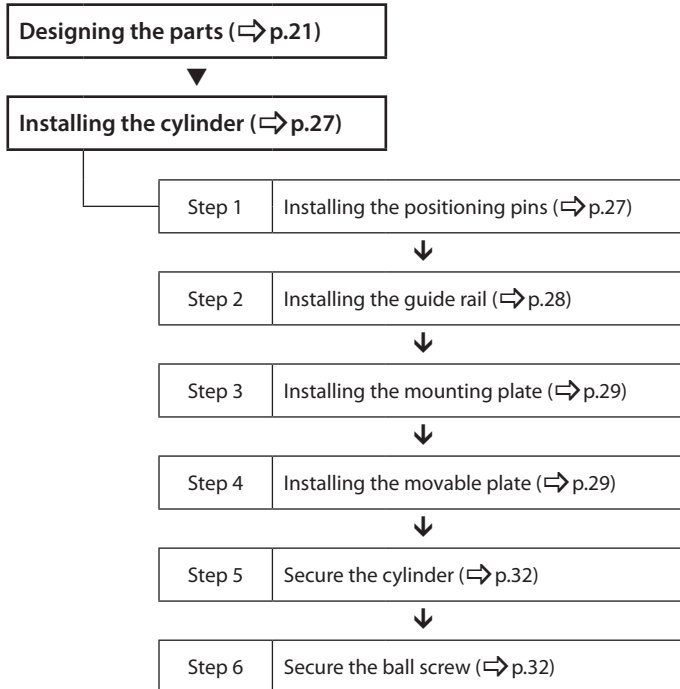

■ For side face mounting

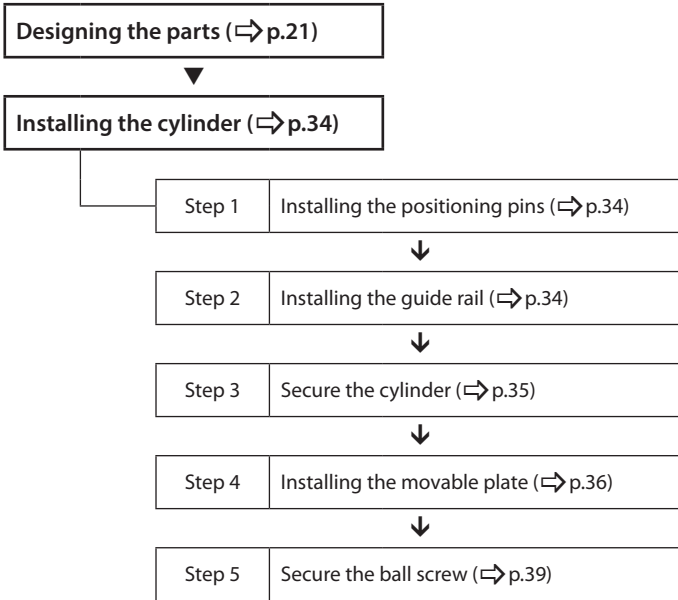

■ For mounting using the foot

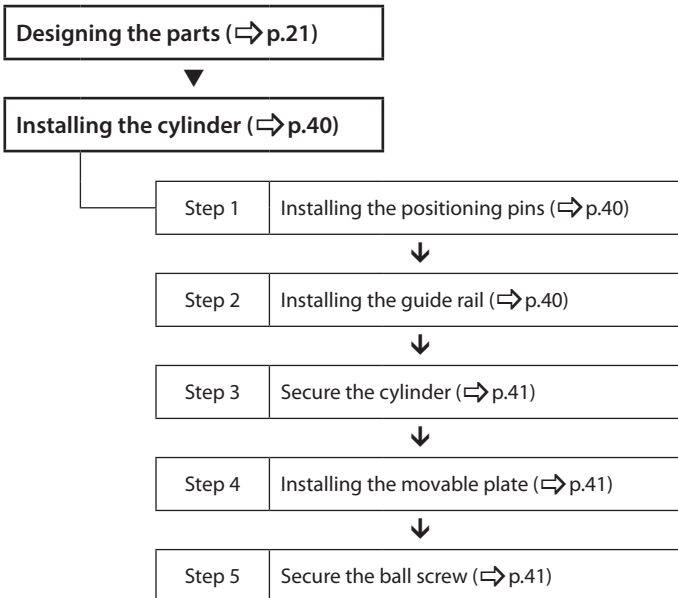

5-5 Component parts design (unit: mm)

The following shows the recommended design dimension of component parts and jigs required when the cylinder is installed.

■ Base plate

When the cylinder is installed with the side face mounting or the mounting using the foot, design a base plate with reference to the size of the positioning pin hole.

● Size of positioning pin holes (For side face mounting)

● DR20

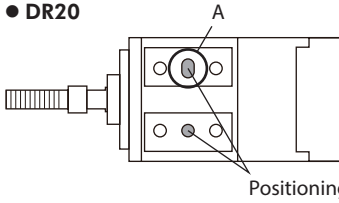

● DR28

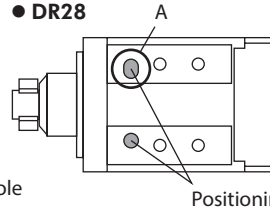

Details of section A



Model	Recommended size of positioning pin	Positioning pin hole (round hole)		Positioning pin hole (elongated hole)		
		Diameter	Depth	E	F	Depth
DR20	$\phi 2 \begin{smallmatrix} 0 \\ -0.01 \end{smallmatrix}$	$\phi 2 \begin{smallmatrix} +0.02 \\ 0 \end{smallmatrix}$	3	$2 \begin{smallmatrix} +0.02 \\ 0 \end{smallmatrix}$	1	3
DR28	$\phi 3 \begin{smallmatrix} 0 \\ -0.01 \end{smallmatrix}$	$\phi 3 \begin{smallmatrix} +0.01 \\ 0 \end{smallmatrix}$	2.5	$3 \begin{smallmatrix} +0.01 \\ 0 \end{smallmatrix}$	1	2.5

When the positioning pins for cylinder are installed on the base plate, design so that the height of the positioning pins are below the specified value in the figure from the top surface of the base plate.

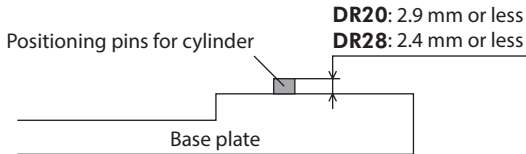

Make sure that the height of the positioning pins are below the specified value in the figure from the top surface of the base plate. Exceeding the specified value may cause the cylinder to break, leading to injury or mechanical damage.

● **Size of positioning pin holes (When mounting using the foot)**

The figure shows the **DR28**.

Recommended size of positioning pin: $\varnothing 3 \begin{smallmatrix} 0 \\ -0.01 \end{smallmatrix}$

Thickness of foot: 8.5

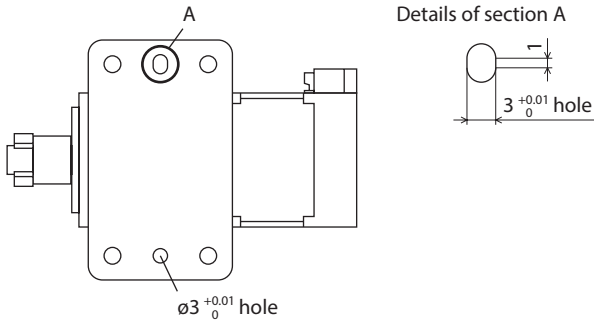

■ **Movable plate**

Combining two pieces of plates, design L-shaped movable plate.

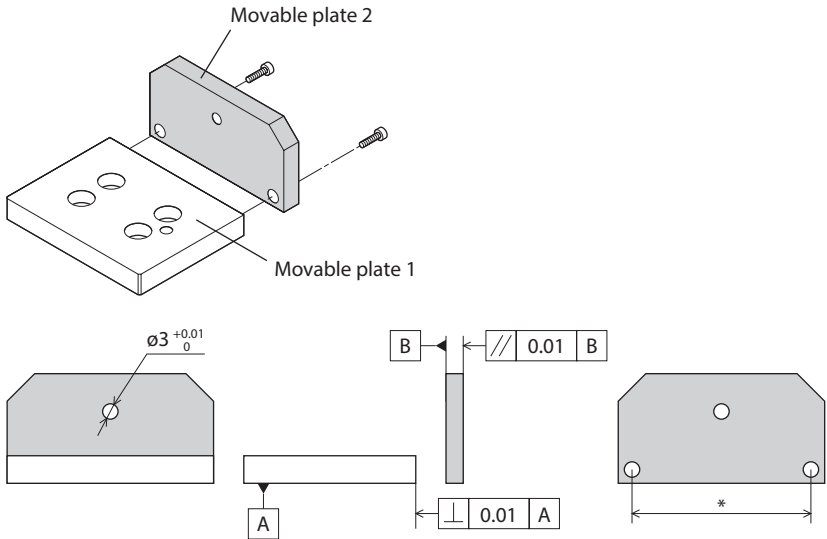

* For front mounting: Design dimensions with the procedure 5 of the Step 4 (p.30) taken into consideration.

For side face mounting: Design dimensions with the procedure 6 of the Step 4 (p.37) taken into consideration.

Note

Chamfer the movable plate as shown in the figure to prevent the ball screw or screw to secure the ball screw from contacting the movable plate. If the ball screw or screw contacts the movable plate, the contact part may deform, and the centering shaft cannot be inserted when centering is performed for maintenance. Besides chamfering the movable plate, there is a way to prevent the screw from contacting the movable plate using a washer.

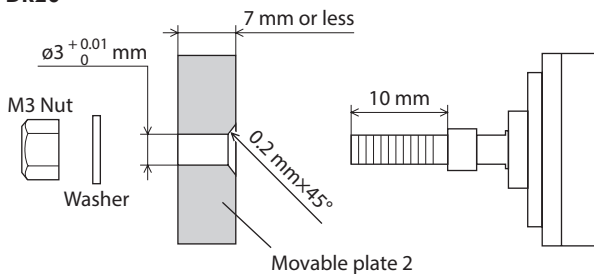
● DR20**● DR28**

Chamfer so that the round part under the screw neck does not contact the movable plate.

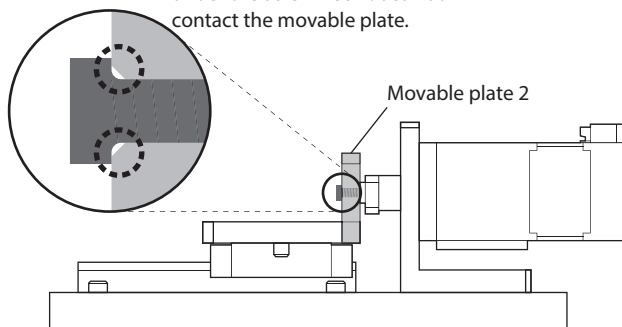

■ Mounting plate (front mounting only)

Make the mounting plate (thickness about 5 mm or more) using a metal plate having excellent vibration resistance and heat conductivity. If a high accuracy is required, design the thickness of the mounting plate in consideration of installation conditions such as load condition, rigidity, vibration, and others.

Perform machining of a flange pilot (counterbore or through hole) on the mounting plate. The figure shows an example for a through hole.

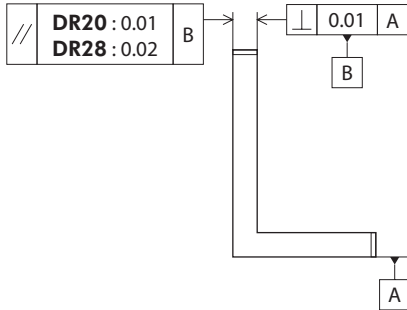

● Flange pilot section

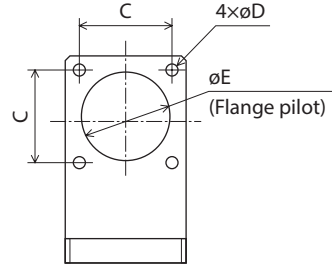

Model	C	øD	øE
DR20	16±0.1	ø2.3	ø16 ^{+0.018} ₀
DR28	23±0.1	ø3	ø22 ^{+0.021} ₀

■ Centering shaft

The centering shaft is a jig that the cylinder and the movable plate are performed the center alignment.

A centering shaft for **DR28** is provided as our product. However, our centering shaft cannot be used depending on the centering conditions. If our centering shaft cannot be used, make the centering shaft by the customer.

● Conditions where our centering shaft PACS-DR28 can be used

For front mounting:

When the center alignment is performed at the position of 15 mm from the mounting surface of the centering shaft

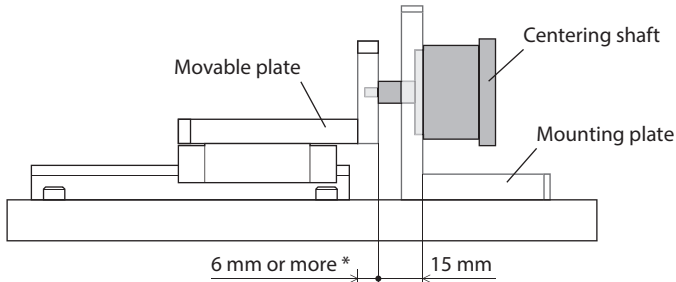

* This is the distance needed for adjusting the center alignment.

For side face mounting or mounting using the foot:

When the center alignment is performed at the position of 32 mm from the mounting surface of the cylinder

The figure shows the side face mounting.

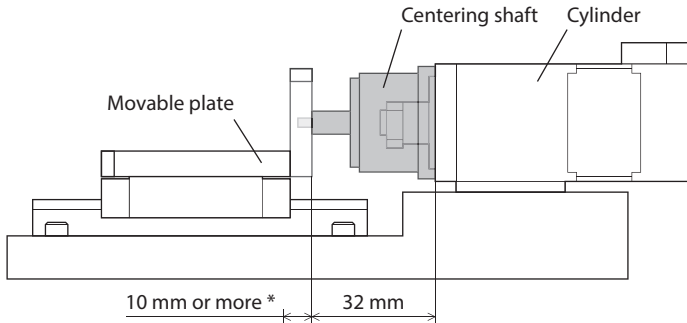

* This is the distance needed for adjusting the center alignment and attaching/detaching of the centering shaft.

● When our centering shaft PACS-DR28 cannot be used

When our centering shaft cannot be used, make a centering shaft according to an installation method.

For front mounting

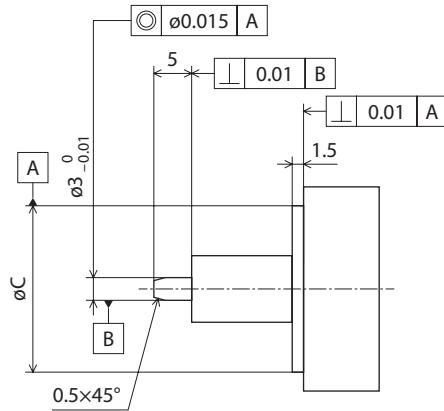

Model	$\varnothing C$
DR20	$\varnothing 16_{-0.018}^0$
DR28	$\varnothing 22_{-0.021}^0$

For side face mounting or mounting using the foot

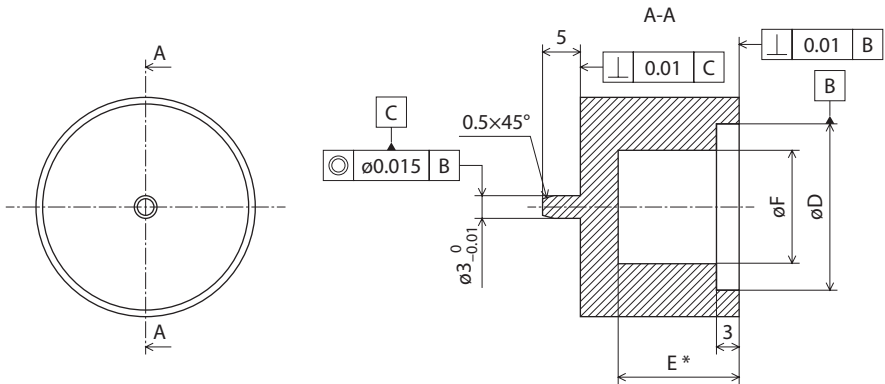

* In order to prevent from contacting the centering shaft and the cylinder, make sure to keep the specification values or more in the table.

Model	$\varnothing D$	E	$\varnothing F$
DR20	$\varnothing 16_{0}^{+0.018}$	21	$\varnothing 15$
DR28	$\varnothing 22_{0}^{+0.021}$	16	$\varnothing 15$

■ Parallelism correction jig (For side face mounting or mounting using the foot)

If a block gauge cannot be used when parallelism between the movable plate and the cylinder is to be obtained, make a parallelism correction jig.

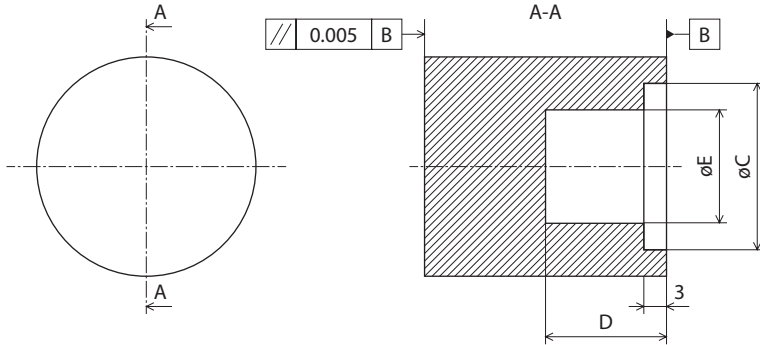

Model	ϕC	D	ϕE
DR20	$\phi 16^{+0.2}_{+0.1}$	21	$\phi 15$
DR28	$\phi 22^{+0.2}_{+0.1}$	16	$\phi 15$

5-6 Installation method

■ For front mounting

The cylinder can be installed in any direction.

Step 1 Installing the positioning pins

Install positioning pins (each two pieces), which are used to set the position of the guide rail and mounting plate, on the base plate.

Positioning pins for mounting plate

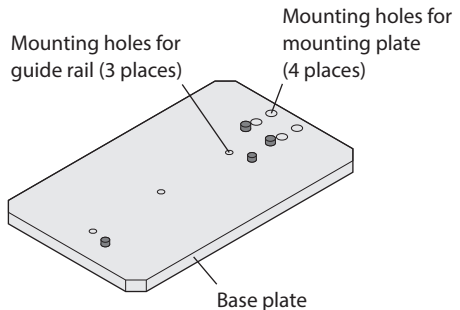
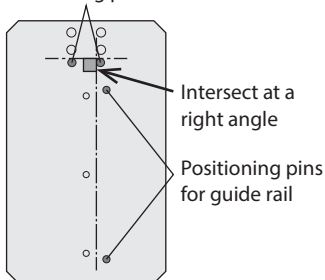

Step 2 Installing the guide rail

1. Secure a guide rail to the base plate with screws while pressing the reference surface of the guide rail to the positioning pins.
Check with a manufacturer of linear guides for the reference surface of the guide rail, screw size, and tightening torque.

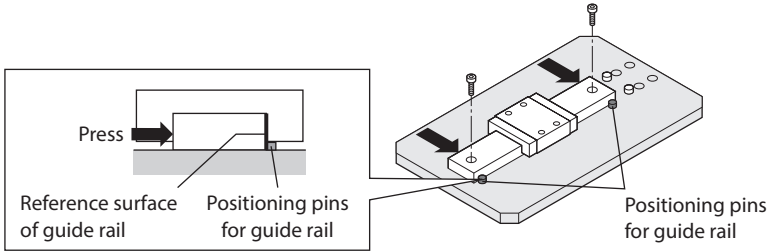

2. Check the traveling parallelism.

Model	Traveling parallelism
DR20	0.02 mm or less (per 25 mm)
DR28	0.03 mm or less (per 30 mm)

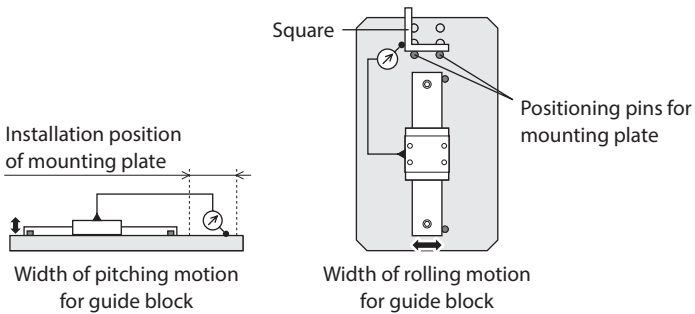

Step 3 Installing the mounting plate

Insert the mounting plate on the positioning pins, and secure the mounting plate to the base plate with screws.

Use screws according to the material and board thickness of the base plate, and tighten with a suitable torque.

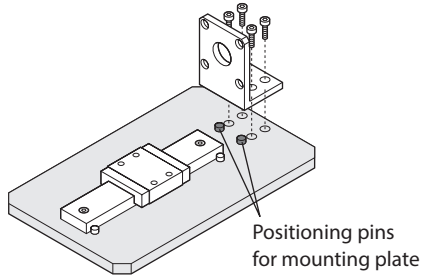

Step 4 Installing the movable plate

1. Secure the movable plate 1 and 2 with screws. Use screws according to the material and board thickness of the movable plate, and tighten with a suitable torque.

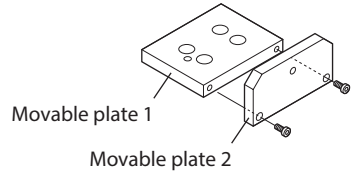

2. Install the positioning pin on the movable plate.

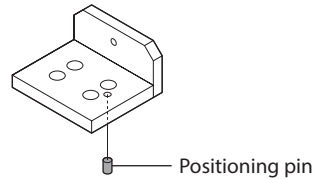

3. Press the movable plate to the mounting plate, and press the positioning pin of the movable plate to the reference surface of the guide block. Check with a manufacturer of linear guides for the reference surface of the guide block.

Press the movable plate to the mounting plate.

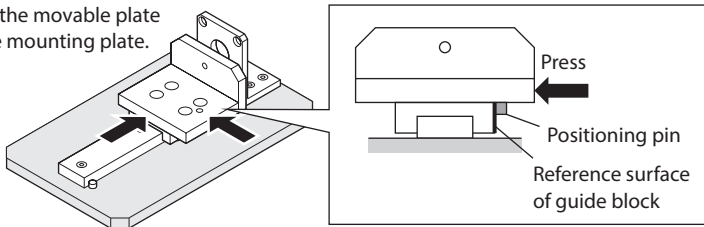

If there is a distance between the movable plate and mounting plate, put a block gauge in between them, and press the movable plate to the block gauge.

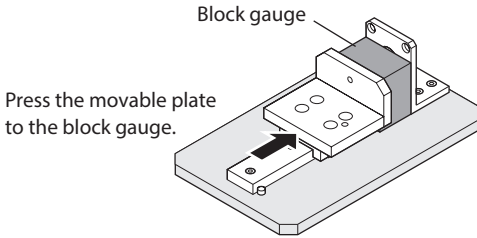

4. Check there is no gap between the movable plate and mounting plate, and secure the movable plate to the guide block with screws.
If there is a gap, reinstall the movable plate.
Check with a manufacturer of linear guides for the screw size and tightening torque.

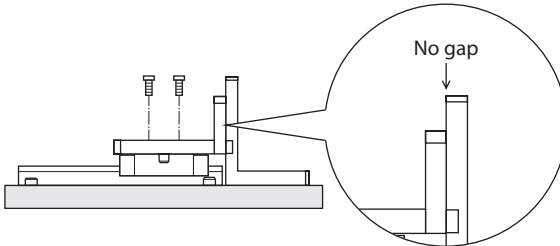

When there is a distance between the movable plate and the mounting plate, put a block gauge, and check that there is no gap between the plates.

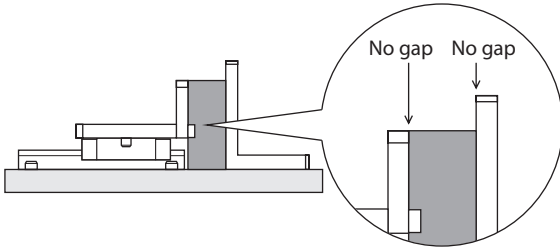

5. Loosen the screws securing the movable plate 1 and movable plate 2, and temporarily fix the screws so as to move slightly when touching the movable plate 2.

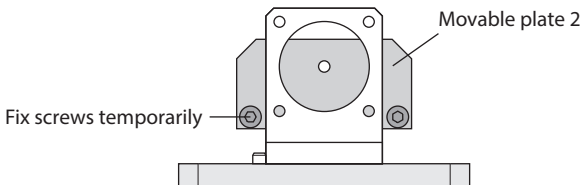

- Using the centering shaft to resemble the cylinder, insert the centering shaft to the mounting plate.

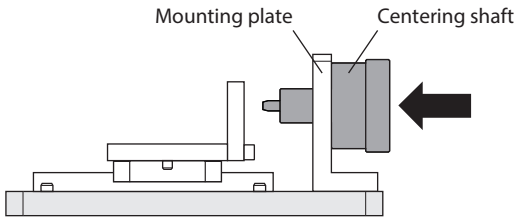

- Slide the movable plate back and forth, and check it can move smoothly so that the centering shaft does not contact.
If the movable plate contacts the centering shaft, adjust the shaft position while moving the movable plate 2 from right to left or up and down little by little.

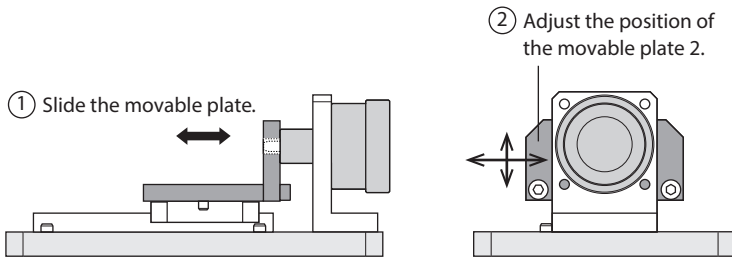

- Tighten the screws of the temporarily fixed movable plate 2.
- Slide the movable plate back and forth, and check it can move smoothly so that the centering shaft does not contact.

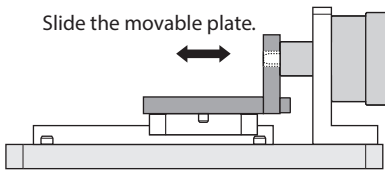

- Remove the centering shaft.

Step 5	Secure the cylinder
---------------	----------------------------

Secure the cylinder to the mounting plate with screws.

Model	Nominal size	Tightening torque	Mounting holes dimension (mm)		
			ϕM	L0	L (Effective depth of screw thread)
DR20	M2	0.4 N·m (56 oz-in)	$\phi 2.3$	2	5
DR28	M2.5	0.5 N·m (71 oz-in)	–	–	5

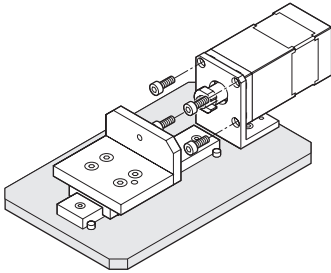

Details of **DR20** mounting hole

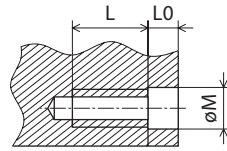

Step 6	Secure the ball screw
---------------	------------------------------

- Turn the ball screw to retract until the stopper of the cylinder touches to the inside of the pilot section lightly.
- Fix the flat sections with a wrench, and secure the movable plate to the end of the ball screw with a screw or a nut.
Fix the flat sections of the ball screw for **DR20** and the flat sections of the stopper for **DR28**.
Use in combination with a thread locking adhesive is recommended.

● **DR20**

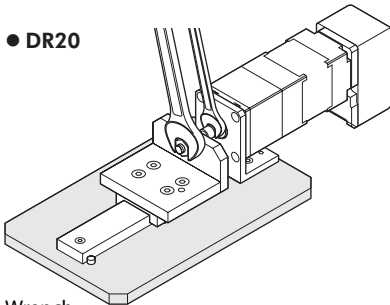

Wrench

For nut: Width across flats dimensions 5.5 mm

For ball screw: Width across flats dimensions 3 mm

● **DR28**

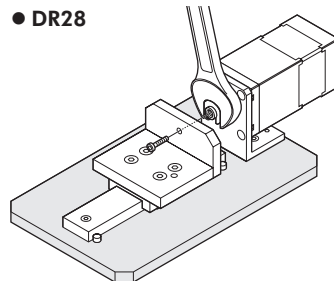

Wrench: Width across flats dimensions 11 mm

Model	Nominal size of screw or nut	Tightening torque
DR20	M3 Nut	0.6 N·m (85 oz-in)
DR28	M3 Screw	1.5 N·m (210 oz-in)

Details of **DR28** load mounting hole (unit: mm)

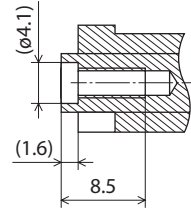

Note

- Be sure to operate after retracting the ball screw. If the screw is tightened in a state where the ball screw remains to be drawn out, the ball screw may incline, leading to malfunction or shorter service life of the cylinder.
- Put a washer if the round part under the screw neck contacts with the movable plate. If it contacts, the contact part may deform.
- Grease is applied on the ball screw. When a thread locking adhesive is used in combination, wipe off the grease on the place shown in the figure using a soft cloth. If the grease is remained applied, a thread locking adhesive may not become hard.

DR20

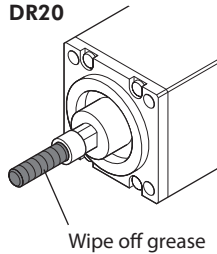

DR28

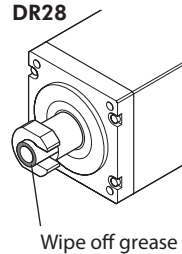

3. Connect the cylinder and the driver to perform test operation.
Check that no abnormal noise is generated.
Refer to the operating manual of the driver for how to connect with the driver and the wiring distance between the cylinder and driver.

■ For side face mounting

The cylinder can be installed in any direction.

When the cylinder is installed in a state where the cable or connector is placed in the downward direction, design the mounting position and base plate so that the cable or connector does not contact the base plate.

Step 1 Installing the positioning pins

Install positioning pins (each two pieces), which are used to set the position of the guide rail and cylinder, on the base plate.

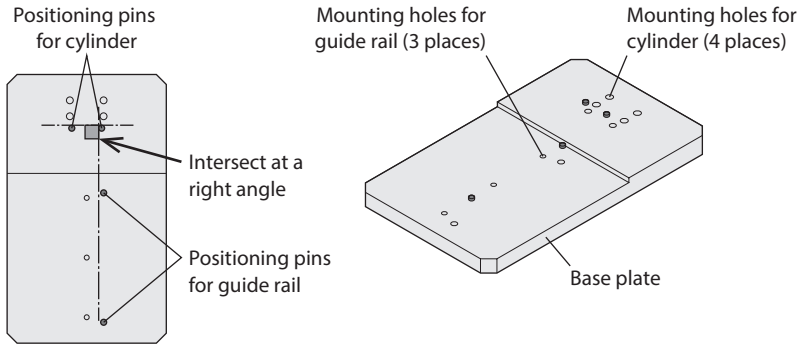

Note

Be sure to install the positioning pins on the base plate. Pressing the positioning pins into the cylinder may cause damage.

Step 2 Installing the guide rail

1. Secure a guide rail to the base plate with screws while pressing the reference surface of the guide rail to the positioning pins.

Check with a manufacturer of linear guides for the reference surface of the guide rail, screw size, and tightening torque.

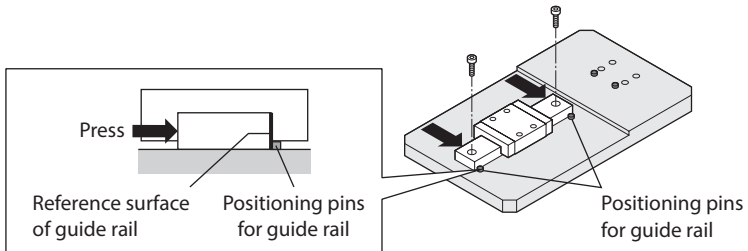

2. Check the traveling parallelism.

Model	Traveling parallelism
DR20	0.02 mm or less (per 25 mm)
DR28	0.03 mm or less (per 30 mm)

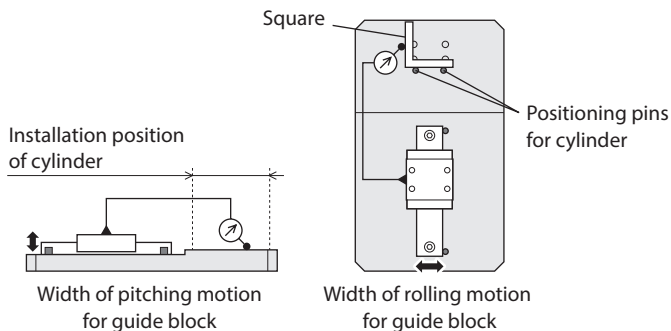

Step 3 **Secure the cylinder**

Secure the cylinder to the base plate with screws while pressing it to the positioning pins. When the cylinder is installed in a state where the cable or connector is placed in the downward direction, install it so that the cable or connector does not contact the base plate.

Model	Nominal size	Tightening torque	Effective depth of screw thread
DR20	M2.5	0.5 N·m (71 oz-in)	3.5 mm
DR28	M3	1 N·m (142 oz-in)	3.5 mm

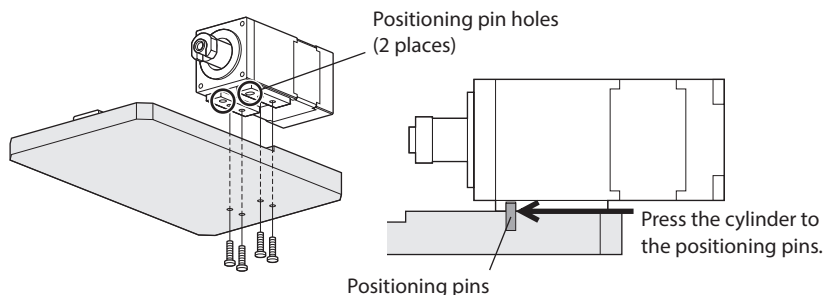

Step 4 Installing the movable plate

1. Secure the movable plate 1 and 2 with screws.
Use screws according to the material and board thickness of the movable plate, and tighten with a suitable torque.

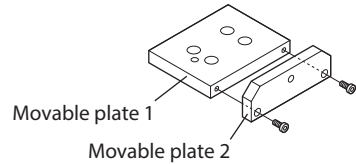

2. Install the positioning pin on the movable plate.

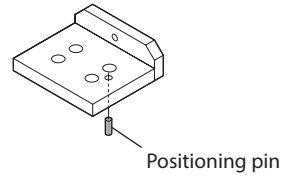

3. Using the block gauges, obtain the parallelism between the movable plate and cylinder.
Place the block gauges with applying against the flange surface of the cylinder.

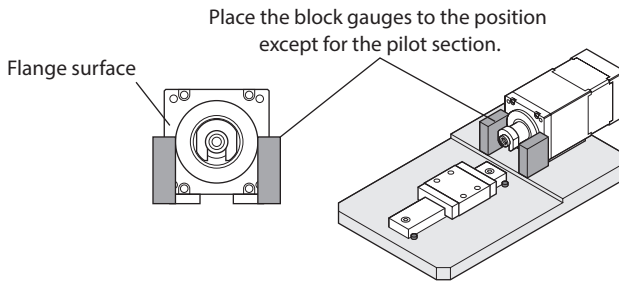

If the block gauges cannot be used, obtain the parallelism using a parallelism correction jig.

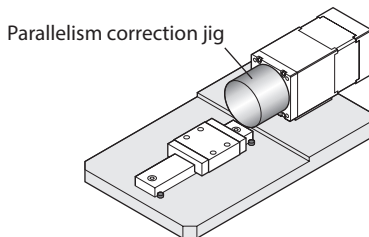

4. Press the positioning pin of the movable plate to the reference surface of the guide block while pressing the movable plate to the block gauges.
Check with a manufacturer of linear guides for the reference surface of the guide block.

Press the movable plate to the block gauge.

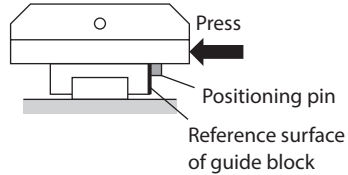
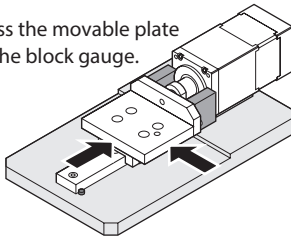

5. Check there is no gap among the movable plate, block gauges, and cylinder, and secure the movable plate to the guide block with screws.
If there is a gap, reinstall the movable plate.
Check with a manufacturer of linear guides for the screw size and tightening torque.

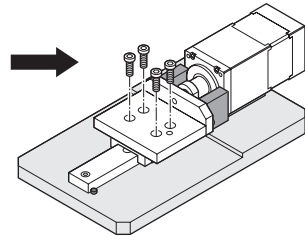
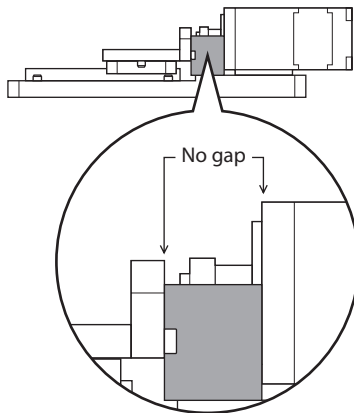

6. Loosen the screws securing the movable plate 1 and movable plate 2, and temporarily fix the screws so as to move slightly when touching the movable plate 2.

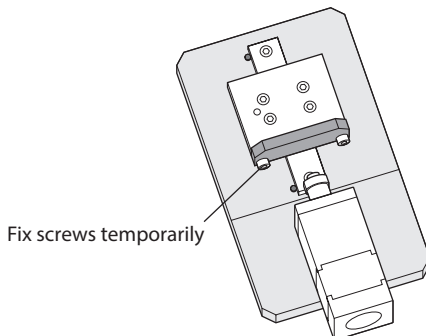

- Turn the ball screw to retract until the stopper of the cylinder touches to the inside of the pilot section lightly, and cover with the centering shaft.
Verify the pilot section of the cylinder is fitted with the centering shaft securely.

Retract the ball screw

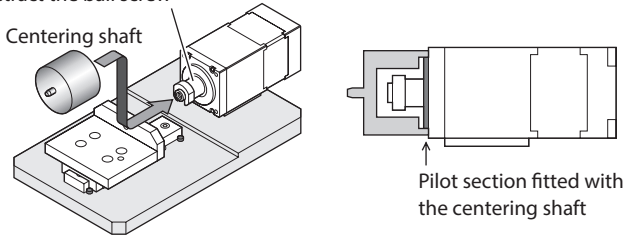

Be sure to operate after retracting the ball screw. If the centering shaft is covered in a state where the ball screw remains to be drawn out, the centering shaft may displace and the cylinder cannot be installed properly.

- Move the movable plate to fit to the centering shaft, and slide the movable plate to check it can move smoothly without contacting the centering shaft.
If the movable plate contacts the centering shaft, adjust the shaft position while moving the movable plate 2 from right to left or up and down little by little.

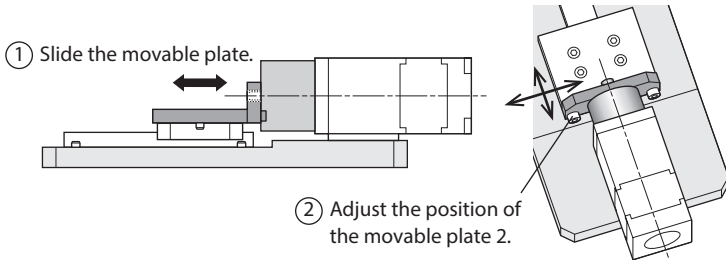

- Tighten the screws of the temporarily fixed movable plate 2.
- Slide the movable plate back and forth, and check it can move smoothly so that the centering shaft does not contact.

Slide the movable plate.

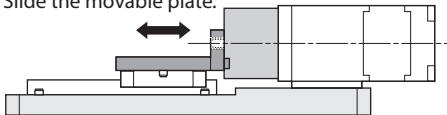

- Remove the centering shaft.

Step 5 Secure the ball screw

- Turn the ball screw to retract until the stopper of the cylinder touches to the inside of the pilot section lightly.
- Fix the flat sections with a wrench, and secure the movable plate to the end of the ball screw with a screw or a nut.
Fix the flat sections of the ball screw for **DR20** and the flat sections of the stopper for **DR28**.
Use in combination with a thread locking adhesive is recommended.

● DR20

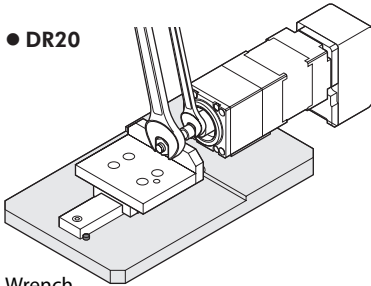

Wrench

For nut: Width across flats dimensions 5.5 mm

For ball screw: Width across flats dimensions 3 mm

● DR28

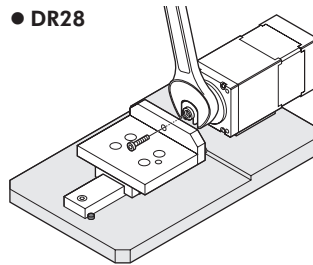

Wrench: Width across flats dimensions 11 mm

Model	Nominal size of screw or nut	Tightening torque
DR20	M3 Nut	0.6 N·m (85 oz-in)
DR28	M3 Screw	1.5 N·m (210 oz-in)

Details of **DR28** load mounting hole (unit: mm)

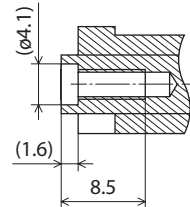

Note

- Be sure to operate after retracting the ball screw. If the screw is tightened in a state where the ball screw remains to be drawn out, the ball screw may incline, leading to malfunction or shorter service life of the cylinder.
- Put a washer if the round part under the screw neck contacts with the movable plate. If it contacts, the contact part may deform.

- Connect the cylinder and the driver to perform test operation.
Check that no abnormal noise is generated.
Refer to the operating manual of the driver for how to connect with the driver and the wiring distance between the cylinder and driver.

■ For mounting using the foot

The cylinder can be installed in any direction.

When the cylinder is installed in a state where the cable or connector is placed in the downward direction, design the mounting position and base plate so that the cable or connector does not contact the base plate.

Step 1 Installing the positioning pins

Install positioning pins (each two pieces), which are used to set the position of the guide rail and cylinder, on the base plate.

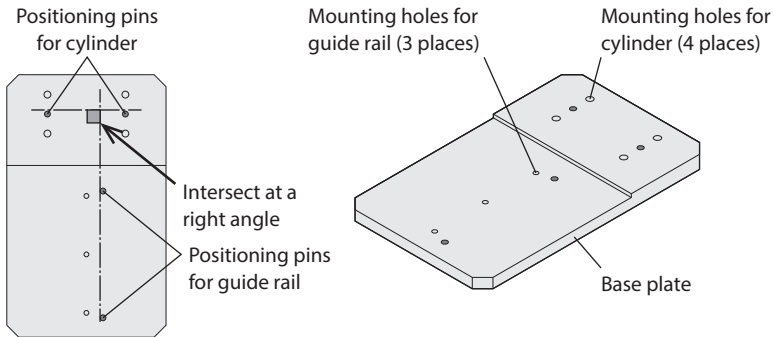

Note

Be sure to install the positioning pins on the base plate. Pressing the positioning pins into the cylinder may cause damage.

Step 2 Installing the guide rail

1. Secure a guide rail to the base plate with screws while pressing the reference surface of the guide rail to the positioning pins. Check with a manufacturer of linear guides for the reference surface of the guide rail, screw size, and tightening torque.

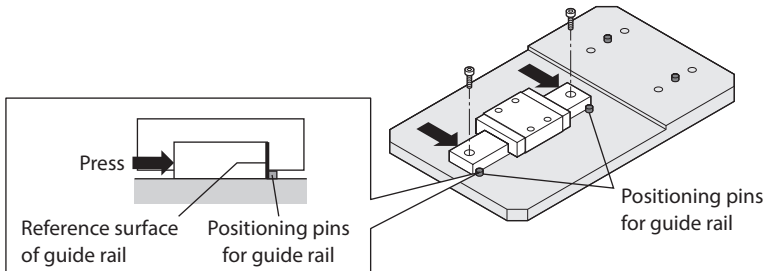

2. Check the traveling parallelism.
 Traveling parallelism: 0.03 mm or less (per 30 mm)

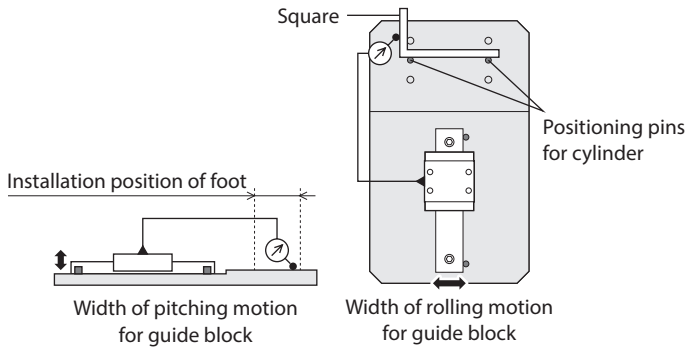

Step 3 Secure the cylinder

Secure the cylinder to the base plate with screws while pressing it to the positioning pins. When the cylinder is installed in a state where the cable or connector is placed in the downward direction, install it so that the cable or connector does not contact the base plate.

Nominal size	Tightening torque
M3	1 N·m (142 oz-in)

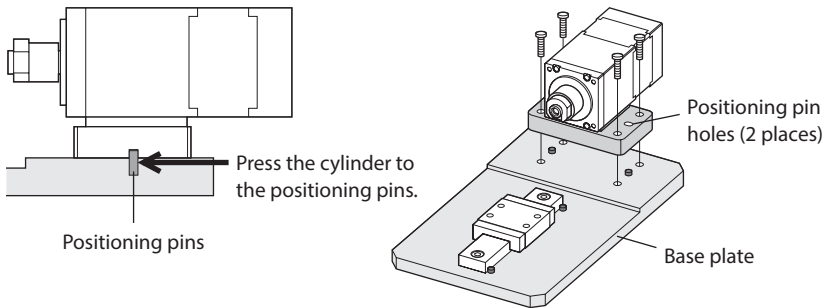

Step 4 Installing the movable plate

The procedure is the same as the side face mounting. Refer to p.36.

Step 5 Secure the ball screw

The procedure is the same as the side face mounting. Refer to p.39.

6 Connection

6-1 Cylinder equipped with the PKP Series

Pin Nos. 2 and 5 are not used.

- Wiring connection diagram
- Pin assignments

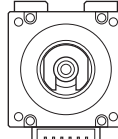
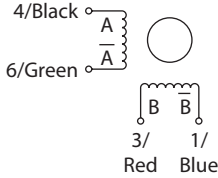

Pin number → 6 5 4 3 2 1

■ Applicable connector/lead wire

Cylinder model	Type	Model
DR28	Connector housing	51065-0600 (Molex Incorporated)
	Contact	50212-8XXX (Molex Incorporated)
	Designated crimping tool	63819-0500 (Molex Incorporated)
	Applicable lead wire	<ul style="list-style-type: none"> ● Diameter of the lead wire: The diameter varies depending on the setting current. <ul style="list-style-type: none"> – When the current value is less than 1 A/phase: AWG28 to 24 (0.08 to 0.2 mm²) – When the current value is 1 A/phase or more: AWG26 to 24 (0.14 to 0.2 mm²) – When the current value is 1.5 A/phase or more: AWG24 (0.2 mm²) ● Outer sheath diameter: ø0.8 to 1.4 mm (ø0.031 to 0.055 in.) ● Stripping length of wire insulation: 1.3 to 1.8 mm (0.051 to 0.071 in.)

■ Connection with the CVD driver of Oriental Motor

Refer to the table when connecting with the **CVD** driver of Oriental Motor. "Color" in the table shows the colors of lead wires of our connection cable.

CVD driver CN2 Pin No.	Cylinder Pin No.	Color
1	1	Blue
2	3	Red
3	–	–
4	6	Green
5	4	Black

6-2 Cylinder equipped with the AZ Series

Refer to the operating manual of the driver for how to connect with the driver and the wiring distance between the cylinder and driver.

7 Inspection and maintenance

7-1 Maintenance item and timing

If the cylinder is operated eight hours a day, perform maintenance according to the applicable period specified in the table. Reduce maintenance intervals accordingly if the operating rate is high such as continuous operation for twenty-four hours.

Maintenance timing	External inspection	External cleaning	Internal inspection
When operated for the first time	○	○	—
A week after initial operation	○	○	○
Every a month thereafter	○	○	○

■ External inspection

Check the items specified in table.

Item	Inspection item	Remedial action
Cylinder	<ul style="list-style-type: none">• Check if any of the screws having installed the cylinder is loose.• Check if any of the screws having installed a load is loose.	Tighten the screws securely.
Cable, connector	<ul style="list-style-type: none">• Check if a damage or stress is applied on the cable.• Check if the connection part between the cylinder and driver is loose.	<ul style="list-style-type: none">• Replace the cable.• Disconnect and reconnect the connector.
Operation	Check if an unusual noise or vibration is generated from a bearing part (ball bearing).	Check the installation of the load and operation speed.

■ External cleaning

Clean the exterior surface of the cylinder whenever necessary.

- Wipe off any dirt and stains using a soft cloth.
- Do not apply compressed air. Dust may enter from a space, resulting in malfunction.
- To remove stubborn stains, wipe the area using a soft cloth moistened with neutral detergent.
- Do not use petroleum solvents, since they will damage the coated surface.

■ Internal inspection

Visually check the items specified in table. Even if the grease has turned brown, lubrication condition is deemed appropriate if the running surface still appears glossy. Refer to "7-2 Applying grease" for how to apply grease.

Item	Inspection item	Remedial action
Ball screw	Check if any of foreign objects such as dust is adhered.	Remove the foreign matter.
	Check if the grease has lost its gloss or has been consumed.	Clean the ball screw with a soft cloth and apply grease.

7-2 Applying grease



Wear protective goggles when applying grease. Pay attention to safety and handle the grease carefully by following the instructions provided with that product. If grease gets into the eyes or comes in contact with the skin, immediately flush the area thoroughly with water.

1. Turn the ball screw by hand to draw from the motor.
In the case of the cylinder with adjusting knob, draw the ball screw by turning the adjusting knob.

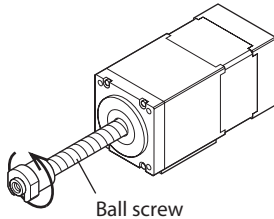

2. Wipe off the old grease and any dirt completely with a soft cloth, and apply new grease to ball screw.
Grease to be used : AFC grease (THK CO., LTD.)

■ For cylinder with ball screw cover

Apply grease to the cylinder with ball screw cover according to the following procedures.



Do not touch the ball screw cover with bare hands. Doing so may cut fingers or the like by the ball screw cover.

1. Turn the ball screw by hand to draw from the motor.
In the case of the cylinder with adjusting knob, draw the ball screw by turning the adjusting knob.
2. Draw the ball screw cover to the end of the ball screw.

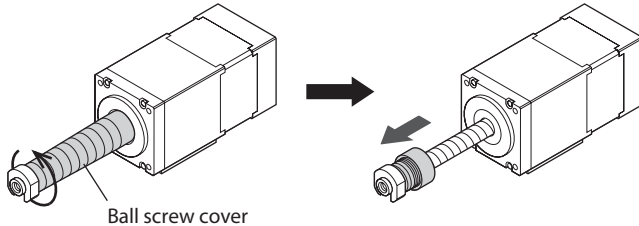

3. Wipe off the old grease and any dirt completely with a soft cloth, and apply new grease to ball screw.
Grease to be used : AFC grease (THK CO., LTD.)
4. Return the ball screw cover, and check that it can be fit in the guide inside the pilot section.

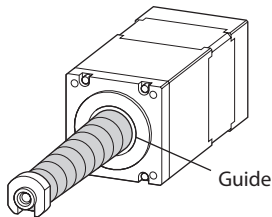

7-3 Warranty

Check on the Oriental Motor Website for the product warranty.

7-4 Disposal

Dispose the product correctly in accordance with laws and regulations, or instructions of local governments.

8 Troubleshooting

During cylinder operation, the cylinder may fail to function properly due to an improper setting or wiring. When the cylinder cannot be operated properly, refer to the contents provided in this section and take an appropriate action. If the problem persists, contact your nearest Oriental Motor sales office.

Phenomenon	Possible cause	Remedial action
The ball screw does not move with being jammed.	The ball screw was hit against an object to stop.	Return the ball screw at the recommended starting speed shown in the table next. After that, check the following items. If the ball screw does not return, remove the load. <ul style="list-style-type: none"> • Is the screw for mounting a load come loose? • Are the ball screw and the load damaged? • Are the positions of the stopper and the home displaced? • Is the mounting accuracy changed?
The ball screw does not operate at the command speed.	The thrust of the cylinder is not enough against a load.	Reconsider the load.
The ball screw rotates idly.	An anti-spin mechanism is not provided.	Provide an anti-spin mechanism such as a guide rail or movable plate.
Malfunction of cylinder.	The installation accuracy is low.	Check the installation accuracy.
The thrust of the cylinder has lowered.	The wiring distance is exceeded the specification value.	Set the distance between the cylinder and driver within the specification value. Cylinder equipped with the PKP Series: 10 m (32.8 ft.) or less Cylinder equipped with the AZ Series: 20 m (65.6 ft.) or less
	The viscosity of the grease was changed.	Refer to "9-2 General specifications" on p.50, and check the operating ambient temperature.

Recommended starting speed

Model	Lead	Recommended starting speed
DR20	1 mm	0.2 mm/s
DR28	1 mm	0.2 mm/s
	2.5 mm	0.5 mm/s

9 Specifications

9-1 Product specifications

- The box (■) in the model name indicates **A** (without additional function) or **N** (with adjusting knob).
- The box (□) in the model name indicates **U** (upward direction), **D** (downward direction), **R** (right direction), or **L** (left direction) representing the cable outlet direction.
- The circle (○) in the model name indicates **-P** (with foot) representing the foot.
The circle (○) is blank for the cylinder without foot.

Cylinder model	Cylinder equipped with the AZ Series	
	DR20R1B02-AZAK □ DR20R1BC02-AZAK □	DR28R1A03-AZAK □○ DR28R1AC03-AZAK □○
Ball screw lead [mm]	1	1
Ball screw type	Precision	Rolled
Repetitive positioning accuracy [mm]	±0.003	±0.01
Lost motion [mm]	0.02 or less	0.05 or less
Minimum travel amount [mm]	0.001	0.001
Transportable mass [kg]	Horizontal	1.5
	Vertical	1.5
Thrust [N]	15	40
Push force [N]	–	–
Holding force [N]	15	40
Stroke [mm]	25	30
Maximum speed [mm/s] *2	20	40
Maximum acceleration [m/s ²]	0.2	0.2
Rated current [A/phase]	–	–
Voltage [V]	–	–
Winding resistance [Ω/phase]	–	–
Connection method	–	–
Inductance [mH/phase]	–	–

*1 When the base step angle is 1.8°/step.

*2 The maximum speed may decrease depending on the ambient temperature or the connection cable length.

Cylinder equipped with the AZ Series		Cylinder equipped with the PKP Series
DR28R1B03-AZAK□○ DR28R1BC03-AZAK□○	DR28R2.5B03-AZAK□○ DR28R2.5BC03-AZAK□○	DR28R2.5B03-P2■K□○ DR28R2.5BC03-P2■K□○
1	2.5	2.5
Precision	Precision	Precision
±0.003	±0.003	±0.003
0.02 or less	0.02 or less	0.02 or less
0.001	0.001	0.0125 *1
4	4	4
4	2	2
40	20	20
–	50	–
40	20	20
30	30	30
40	100	100
0.2	0.5	0.5
–	–	1.5
–	–	1.77
–	–	1.18
–	–	Bipolar
–	–	0.76±20 %

Operating environment	Ambient temperature	0 to +40 °C [+32 to +104 °F] (non-freezing)
	Ambient humidity	85 % or less (non-condensing)
	Altitude	Up to 1,000 m (3,300 ft.) above sea level
	Surrounding atmosphere	No corrosive gas, dust, water or oil
Storage environment, Shipping environment	Ambient temperature	-20 to +60 °C [-4 to +140 °F] (non-freezing)
	Ambient humidity	85 % or less (non-condensing)
	Altitude	Up to 3,000 m (10,000 ft.) above sea level
	Surrounding atmosphere	No corrosive gas, dust, water or oil
Heat resistance class		130 (B)
Insulation resistance		100 MΩ or more when 500 VDC megger is applied between the following places: Case - Motor windings
Dielectric strength		Sufficient to withstand the following for 1 minute. Case - Motor windings 0.5 kVAC 50 Hz or 60 Hz

10 Regulations and standards

10-1 CE Marking/UKCA Marking

■ EU EMC Directive/UK EMC Regulation

The driver combining with the actuator is affixed the marks under the EMC. For details about applicable standards and others, check with the operating manual of the driver.

10-2 EU RoHS Directive/UK RoHS Regulation

This product does not contain the substances exceeding the restriction values.

- Unauthorized reproduction or copying of all or part of this Manual is prohibited.
If a new copy is required to replace an original manual that has been damaged or lost, please contact your nearest Oriental Motor sales office.
- Oriental Motor shall not be liable whatsoever for any problems relating to industrial property rights arising from use of any information, circuit, equipment or device provided or referenced in this manual.
- Characteristics, specifications and dimensions are subject to change without notice.
- While we make every effort to offer accurate information in the manual, we welcome your input. Should you find unclear descriptions, errors or omissions, please contact your nearest Oriental Motor sales office.
- **Orientalmotor**, **αSTEP** and ABZO sensor are registered trademarks or trademarks of Oriental Motor Co., Ltd., in Japan and other countries.
Other product names and company names mentioned in this manual may be registered trademarks or trademarks of their respective companies and are hereby acknowledged. The third-party products mentioned in this manual are recommended products, and references to their names shall not be construed as any form of performance guarantee. Oriental Motor is not liable whatsoever for the performance of these third-party products.

© Copyright ORIENTAL MOTOR CO., LTD. 2018

Published in May 2023

- Please contact your nearest Oriental Motor office for further information.

ORIENTAL MOTOR U.S.A. CORP.
Technical Support Tel:800-468-3982
8:30am EST to 5:00pm PST (M-F)
www.orientalmotor.com

ORIENTAL MOTOR (EUROPA) GmbH
Schiessstraße 44, 40549 Düsseldorf, Germany
Technical Support Tel:00 800/22 55 66 22
www.orientalmotor.de

ORIENTAL MOTOR (UK) LTD.
Unit 5 Faraday Office Park, Rankine Road,
Basingstoke, Hampshire RG24 8QB UK
Tel:+44-1256347090
www.oriental-motor.co.uk

ORIENTAL MOTOR (FRANCE) SARL
Tel:+33-1 47 86 97 50
www.orientalmotor.fr

ORIENTAL MOTOR ITALIA s.r.l.
Tel:+39-02-93906347
www.orientalmotor.it

ORIENTAL MOTOR ASIA PACIFIC PTE. LTD.
Singapore
Tel:1800-842-0280
www.orientalmotor.com.sg

ORIENTAL MOTOR (MALAYSIA) SDN. BHD.
Tel:1800-806-161
www.orientalmotor.com.my

ORIENTAL MOTOR (THAILAND) CO., LTD.
Tel:1800-888-881
www.orientalmotor.co.th

ORIENTAL MOTOR (INDIA) PVT. LTD.
Tel:1800-120-1995 (For English)
1800-121-4149 (For Hindi)
www.orientalmotor.co.in

TAIWAN ORIENTAL MOTOR CO., LTD.
Tel:0800-060708
www.orientalmotor.com.tw

SHANGHAI ORIENTAL MOTOR CO., LTD.
Tel:400-820-6516
www.orientalmotor.com.cn

INA ORIENTAL MOTOR CO., LTD.
Korea
Tel:080-777-2042
www.inaom.co.kr

ORIENTAL MOTOR CO., LTD.
4-8-1 Higashiueno, Taito-ku, Tokyo
110-8536 Japan
Tel:+81-3-6744-0361
www.orientalmotor.co.jp