

Drivers for 2-Phase, 5-Phase Stepping Motors

CVD Series

RS-485 communication type

USER MANUAL

Thank you for purchasing an Oriental Motor product.
This Manual describes product handling procedures and safety precautions.

- Please read it thoroughly to ensure safe operation.
- Always keep the manual where it is readily available.

Table of contents

Introduction

1	Before use.....	3
1-1	Operating manuals.....	3
1-2	Overview of the product.....	4
2	Safety precautions.....	5
3	Precautions for use.....	7



How to use *

STEP 1	Checking the product	8
1-1	Package contents.....	8
1-2	How to identify the product model	8
1-3	Products possible to combine.....	9
1-4	Information about nameplate.....	9
1-5	Names and functions of parts	10
STEP 2	Installation	11
2-1	Installation location.....	11
2-2	Installation direction.....	11
2-3	Installation method.....	13
STEP 3	Connection.....	15
3-1	Connecting the motor (CN2): 2-phase stepping motor	16
3-2	Connecting the motor (CN2): 5-phase stepping motor and motorized actuator	17
3-3	Connecting the main power supply (CN1)	18
3-4	Connecting the RS-485 communication compatible product (CN4, CN5).....	20
3-5	Connecting the USB cable (CN3).....	22
3-6	Connecting the I/O signals (CN6).....	22
STEP 4	Setting the applicable product ..	25
STEP 5	Settings related to RS-485 communication.....	27
5-1	Setting of termination resistor	27
5-2	Setting of communication parameters.....	28

* This manual describes contents from checking the product to settings related to RS-485 communication. Refer to the **CVD** Series RS-485 communication type [OPERATING MANUAL Function Edition](#) for control methods via Modbus RTU (RS-485 communication) as well as operating methods of the product.

Measures for various cases

4	Inspection and maintenance.....	30
5	Alarms	31
6	Information	39
7	Troubleshooting and remedial actions.....	46

Reference

8	Cables.....	48
9	Accessories	50
10	Specifications	51
11	Regulations and standards	52
12	Noise elimination measures	53

1 Before use

Only qualified personnel of electrical and mechanical engineering should work with the product.

Use the product correctly after thoroughly reading the section "2 Safety precautions" on p.5. In addition, be sure to observe the contents described in warning, caution, and note in this manual.

The product described in this manual is designed and manufactured to be incorporated in general industrial equipment. Do not use for any other purpose. Oriental Motor Co., Ltd. is not responsible for any compensation for damage caused through failure to observe this warning.

1-1 Operating manuals

■ Related operating manuals

For operating manuals, download from Oriental Motor Website Download Page or contact your nearest Oriental Motor sales office.

Also read the operating manual of the motor used in combination with a driver.

- CVD Series RS-485 communication type USER MANUAL (this document)
- CVD Series RS-485 communication type OPERATING MANUAL Function Edition

■ How to use operating manuals

To use the product, read this manual together with the **CVD Series RS-485 communication type OPERATING MANUAL Function Edition**.

This document (USER MANUAL) describes the contents specific to the **CVD Series RS-485 communication type driver**, and the **CVD Series RS-485 communication type OPERATING MANUAL Function Edition** describes operating methods, input/output signals, and control methods via Modbus RTU (RS-485 communication). Refer to the **CVD Series RS-485 communication type OPERATING MANUAL Function Edition** for the contents not included in this manual.

● When the screen display of the support software MEXE02 is described

When the screen display of the **MEXE02** with software version 4 is described, it may be indicated using a number such as "(p10)" described in front of the parameter type.

Example of description

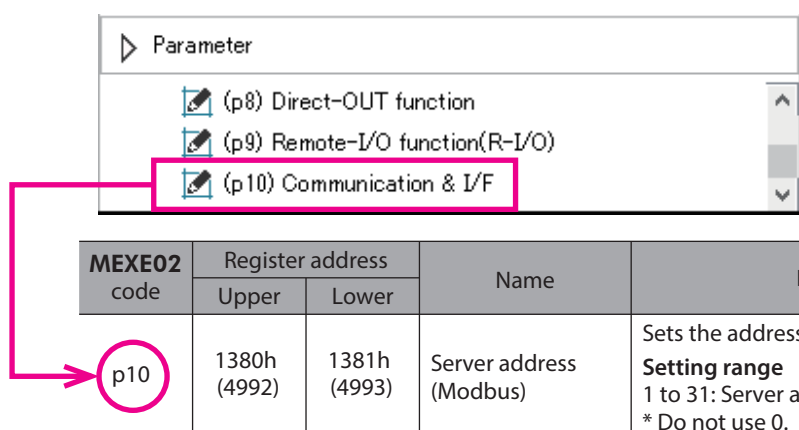

MEXE02 code	Register address		Name	Description	Initial value
	Upper	Lower			
(p10)	1380h (4992)	1381h (4993)	Server address (Modbus)	Sets the address number (server address). Setting range 1 to 31: Server address* * Do not use 0.	1

1-2 Overview of the product

The **CVD** Series RS-485 communication type drivers are DC power input products for 2-phase and 5-phase stepping motors.

■ Lineup

Two types of drivers, which are for 2-phase stepping motors and 5-phase stepping motors, are provided.

■ Low vibration and low noise

A board type microstep driver equipped with the smooth drive function achieves low vibration and low noise operation.

■ Compatible with industrial network

These drivers are compatible with Modbus RTU (RS-485 communication).

Operation data and parameters can be set and also operation can be executed and stopped via RS-485 communication.

Operation data and parameters can also be set using the **MEXE02**.

■ Operation types

Positioning operation, return-to-home operation, continuous operation and other operations can be executed.





Up to 256 operation data points can be set, and multi-point positioning can also be performed.

■ Equipped with direct data operation function

The direct data operation is a function to start operation at the same time as rewriting of the data. It is suitable when the setting of the operation data is changed frequently such as changing the speed or travel amount according to a load.

2 Safety precautions

The precautions described below are intended to ensure the safe and correct use of the product, and to prevent the customer and others from exposure to the risk of injury. Use the product only after carefully reading and fully understanding these instructions.

 WARNING	Handling the product without observing the instructions that accompany a “WARNING” symbol may result in serious injury or death.
 CAUTION	Handling the product without observing the instructions that accompany a “CAUTION” symbol may result in injury or property damage.
	The items under this heading contain important handling instructions that the user should observe to ensure the safe use of the product.
	The items under this heading contain related information and contents to gain a further understanding of the text in this manual.

WARNING

General

- Do not use the driver in explosive or corrosive environments, in the presence of flammable gases, in places subjected to splashing water, or near combustibles. Doing so may result in fire or injury.
- Assign qualified personnel to the task of installing, wiring, operating/controlling, inspecting, and troubleshooting the driver. Failure to do so may result in fire, injury, or damage to equipment.
- When an alarm is generated in the driver (any of the driver’s protective functions is triggered), remove the cause before clearing the alarm (protective function). Continuing the operation without removing the cause of the problem may cause malfunction of the motor and driver, leading to injury or damage to equipment.

Installation

- Install the driver inside an enclosure. Failure to do so may result in injury.

Connection

- Always keep the power supply voltage of the driver within the specified range. Failure to do so may result in fire.
- Connect the cables securely according to the wiring diagram. Failure to do so may result in fire.
- Do not forcibly bend, pull, or pinch the cable. Doing so may result in fire.

Operation

- Turn off the main power supply in the event of a power failure. Failure to do so may result in injury or damage to equipment.
- Do not remove the motor excitation during operation. Doing so may cause the motor to stop and lose the holding force, resulting in injury or damage to equipment.
- For a main power supply, use a DC power supply with reinforced insulation on its primary and secondary sides. Failure to do so may result in electric shock.

Repair, disassembly and modification

- Do not disassemble or modify the driver. Doing so may result in injury or damage to equipment.

 **CAUTION**

General

- Do not use the driver beyond its specifications. Doing so may result in injury or damage to equipment.
- Do not insert a finger or an object between the board and the heat sink. Doing so may result in fire or injury.
- Do not touch the driver during operation or immediately after stopping. Doing so may result in a skin burn(s).
- Do not forcibly bend or pull the cable that is connected to the driver. Doing so may cause damage to the product.

Installation

- Do not place combustibles around the driver. Doing so may result in fire or a skin burn(s).
- Do not leave anything around the driver that would obstruct ventilation. Doing so may result in damage to equipment.

Operation

- Use a motor and driver only in the specified combination. An incorrect combination may cause a fire.
- Provide an emergency stop device or emergency stop circuit external to the equipment so that the entire equipment will operate safely in the event of a system failure or malfunction. Failure to do so may result in injury.
- Before supplying main power to the driver, turn all input signals to the driver to OFF. Failure to do so may result in injury or damage to equipment.
- When moving the moving part manually, put the motor into a non-excitation state. Continuing the work while the motor is in an excitation state may result in injury.
- When an abnormal condition has occurred, immediately stop operation to turn off the main power supply. Failure to do so may result in fire or injury.

3 Precautions for use

This chapter covers restrictions and requirements the user should consider when using the product.

- **When conducting the insulation resistance measurement or the dielectric strength test, be sure to separate the connection between the motor and the driver.**

Conducting the insulation resistance measurement or dielectric strength test with the motor and driver connected may result in damage to the product.

- **Note on connecting a main power supply whose positive terminal is grounded**

The USB communication connector (CN3) of the driver is not electrically insulated. When grounding the positive terminal of the main power supply, do not connect any equipment (PC, etc.) whose negative terminal is grounded. Doing so may cause the driver and these equipment to short, damaging both. When connecting, do not ground equipment.

- **Storing data in non-volatile memory**

Do not turn off the main power supply while writing the data to the non-volatile memory, and also do not turn off for 5 seconds after the completion of writing the data. Doing so may abort writing the data and cause an alarm of the EEPROM error to generate. The non-volatile memory can be rewritten approximately 100,000 times.

- **Noise elimination measures**

Refer to p.53 for the noise elimination measures.

- **Regeneration**

When a large load inertia is operated at a high speed, the power supply voltage may increase by the regenerative energy generated, causing an alarm of overvoltage to generate. This may result in damage to the driver, so reconsider the operating condition so as not to generate the regenerative voltage.

STEP 1 Checking the product

1-1 Package contents

Verify that the items listed below are included. Report any missing or damaged items to the Oriental Motor sales office from which you purchased the product.

- Driver 1 unit
- Instructions and Precautions for Safe Use 1 copy



When taking out the driver from the electrostatic discharge (ESD) protection bag, make sure your hands are not charged with static electricity. Static electricity may cause damage to the driver.

1-2 How to identify the product model

Check the model name of the driver against the model name shown on the nameplate. Refer to p.9 for how to identify the nameplate.

CVD 2 B R - K R
 1 2 3 4 5 6

1	Series	CVD: CVD Series
2	Number of phases of motor	2: 2-phase 5: 5-phase
3	Driver shape	B: Driver with mounting plate
4	Connector shape	R: Right angle Blank: Vertical
5	Power supply input	K: DC power supply
6	Type	R: RS-485 communication type

1-3 Products possible to combine

Products with which the driver can be combined are listed below. Check the model name of the product with the nameplate.

Driver model	Product type	Applicable Series	Product possible to combine *1	
CVD2B-KR CVD2BR-KR	2-phase stepping motor bipolar	PKP Series	PKP213D05■	PKP24□D23■2
			PKP214D06■	PKP24□MD15■
CVD5B-KR CVD5BR-KR	5-phase stepping motor	PKP Series	PKP22□D15■	PKP24□MD15■2
			PKP22□D15■2	PKP25□D28■A2
			PKP22□MD15■	PKP262FD15A
			PKP23□D15■	PKP26□D14■2
			PKP23□D23■	PKP26□D28■
			PKP24□D08■2	PKP26□D28■2
	Motorized actuator	DH Series DRLII Series	PKP24□D15■	PKP26□MD28■
			PKP24□D15■2	PKP26□MD28■2
			PKP24□D23■	
			PK513	PK54□
			PK52□H	PK56□ *2
			PK52□P	
CVD5B-KR CVD5BR-KR	5-phase stepping motor	PKP Series	PKP52□N03	PKP54□MN
			PKP52□N07	PKP54□N18■
			PKP52□N12	PKP54□N18■2
			PKP52□MN03	PKP56□FMN
Motorized actuator	DH Series DRLII Series	PKP52□MN07	PKP56□FN24■2	
		DHM28PAK2	DHM42PAK	
		DRLM20	DRLM42	
		DRLM28	DRLM60	

*1 Model names in the table describe part of the entire name of models. Drivers can be combined with products that include the model names listed here.

The box (□) in the model name indicates a number representing the motor length.

The box (■) in the model name indicates **A** (single shaft) or **B** (double shaft) representing the shape.

*2 Motors with the rated current of 1.4 A/phase are available.

1-4 Information about nameplate

The figure shows an example.



memo The position describing the information may vary depending on the product.

1-5 Names and functions of parts

The figure shows the driver which connector shape is of right angle.

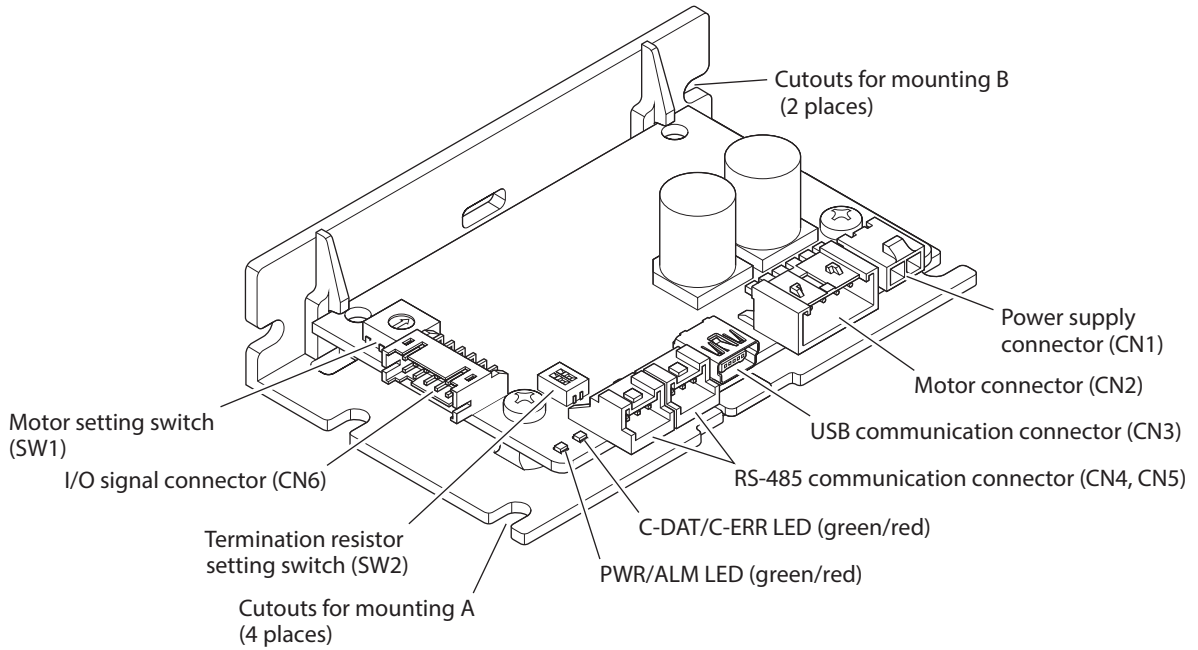

Type	Name	Description
LED	PWR/ALM LED (Green/Red)	<ul style="list-style-type: none"> This LED is lit in green while the main power supply is turned on. If an alarm (protective function) is generated, the LED will blink in red. If information is generated, the LED will simultaneously blink in red and green twice. (Green and red colors may overlap and it may be visible to orange.)
	C-DAT/C-ERR LED (Green/Red)	<ul style="list-style-type: none"> This LED will blink or illuminate in green when the driver is communicating with the host controller properly via RS-485 communication. This LED will be lit in red if a RS-485 communication error occurs with the host controller.
Switch	Motor setting switch (SW1)	Sets this switch according to the product combined. Factory setting: 0
	Termination resistor setting switch (SW2)	Sets the termination resistor (120 Ω) of RS-485 communication. Factory setting: OFF for both No.1 and No.2 (termination resistor disabled)
Connector	Power supply connector (CN1)	Connects the main power supply.
	Motor connector (CN2)	Connects the motor.
	USB communication connector (CN3)	Connects a PC in which the MEXE02 has been installed. (USB2.0 mini-B port)
	RS-485 communication connectors (CN4, CN5)	Connects the RS-485 communication compatible product.
	I/O signal connector (CN6)	Connects when using direct I/O or sensors.

STEP 2 Installation

2-1 Installation location

The driver is designed and manufactured to be incorporated in equipment. Install it in a well-ventilated location that provides easy access for inspection. The location must also satisfy the following conditions:

- Inside an enclosure that is installed indoors (provide vent holes)
- Operating ambient temperature 0 to +50 °C (+32 to +122 °F) (non-freezing)
- Operating ambient humidity 85 % or less (non-condensing)
- Area free of explosive atmosphere, toxic gas (such as sulfuric gas), or liquid
- Area not exposed to direct sun
- Area free of excessive amount of dust, iron particles or the like
- Area not subject to splashing water (rain, water droplets), oil (oil droplets), or other liquids
- Area free of excessive salt
- Area not subject to continuous vibrations or excessive shocks
- Area free of excessive electromagnetic noise (from welders, power machinery, etc.)
- Area free of radioactive materials, magnetic fields or vacuum
- Up to 1,000 m (3,300 ft.) above sea level

2-2 Installation direction

Install the driver in vertical or horizontal position on a flat metal plate having excellent vibration resistance. If the driver is installed in a state other than vertical or horizontal position, its heat radiation effect will deteriorate. The items shown below are necessary in order to install the driver. They must be provided by the customer.

Items to be prepared	Cutouts for mounting A	Cutouts for mounting B
M3 screw	4 pcs.	2 pcs.
M3 spring washer	4 pcs.	2 pcs.
M3 nut *	4 pcs.	2 pcs.

* Not necessary if screw holes are provided in the enclosure.

There must be clearances of at least 25 mm (0.98 in.) and 50 mm (1.97 in.) in the horizontal and vertical directions respectively, between the driver and enclosure or other equipment within the enclosure. When two or more drivers are to be installed side by side, provide clearances in the horizontal and vertical directions as shown in the figure. The figure shows the driver which connector shape is of right angle.



- Install the driver inside an enclosure
- Do not install any equipment that generates a large amount of heat or noise near the driver.
- If the ambient temperature of the driver exceeds 50 °C (122 °F), reconsider the ventilation condition.

• Horizontal installation [Unit: mm (in.)]

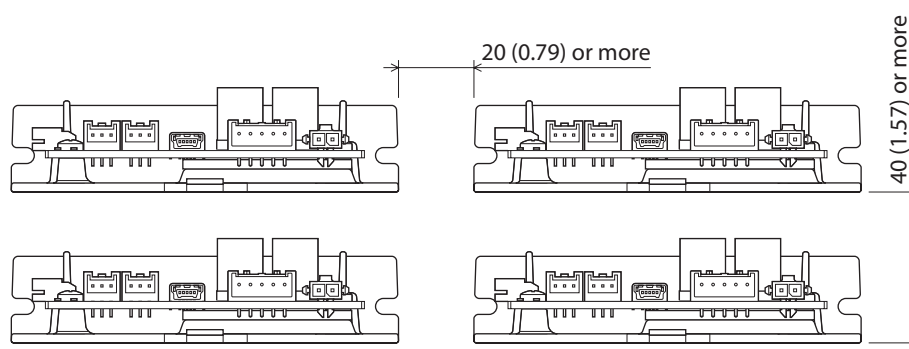

● Vertical installation [Unit: mm (in.)]

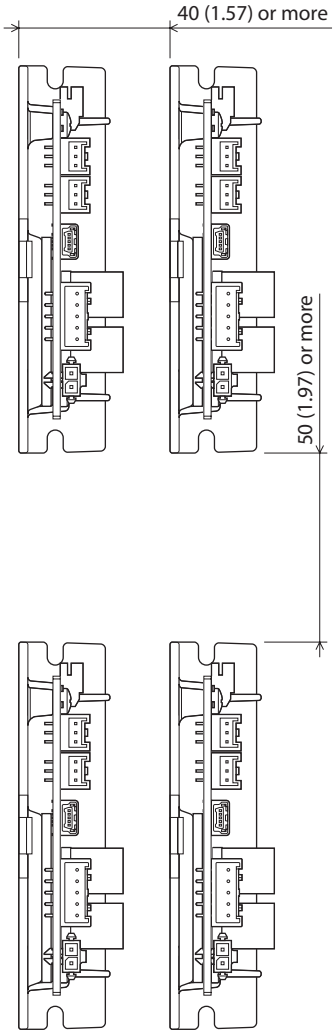

2-3 Installation method

Install the driver using either the “cutouts for mounting A” or “cutouts for mounting B.”
 Torque the mounting screw to 0.5 N·m (71 oz-in).
 The figure shows the driver which connector shape is of right angle.

Note If both cutouts A and B are used for installation, the heat sink is distorted, causing the board to apply stress.

memo When tightening the screws, make sure that the screw tightening tool does not touch the I/O signal connector (CN6).

- **Horizontal installation**

Install the driver in a direction shown in the figure. Installing the driver upside down causes the heat radiation effect to deteriorate.

- **When using the cutouts for mounting A**

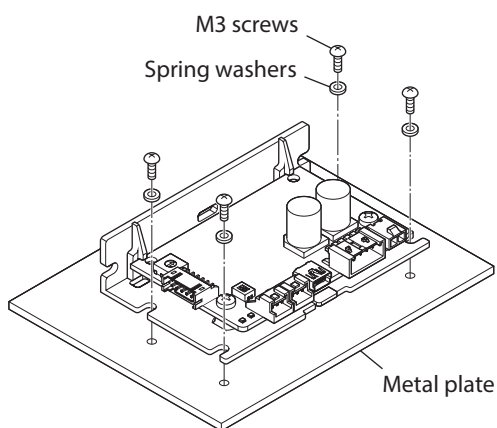

- **When using the cutouts for mounting B**

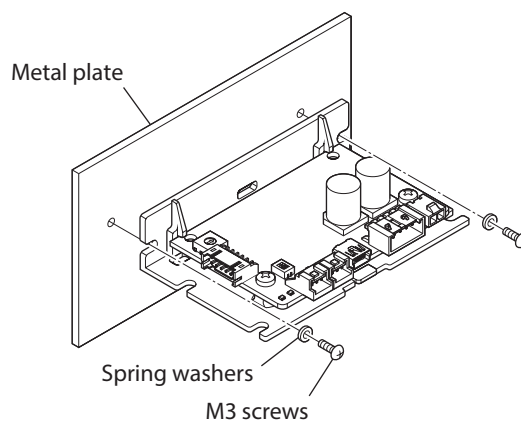

- **Vertical installation**

The driver can be installed in any direction.

- **When using the cutouts for mounting A**

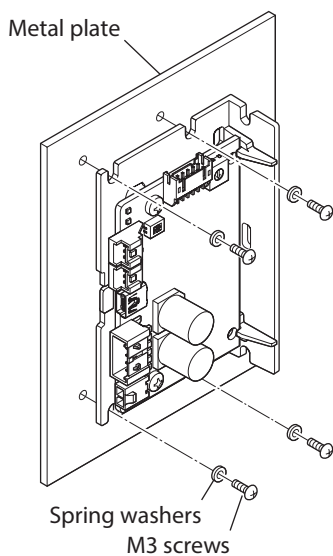

- **When using the cutouts for mounting B**

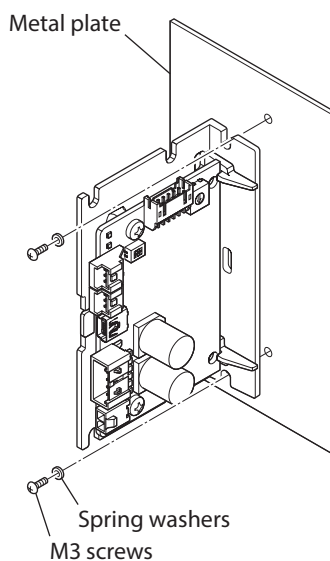

■ **Dimensions [Unit: mm (in.)]**

● **When the connector shape is "Vertical"**

Mass: 0.065 kg (2.3 oz.)

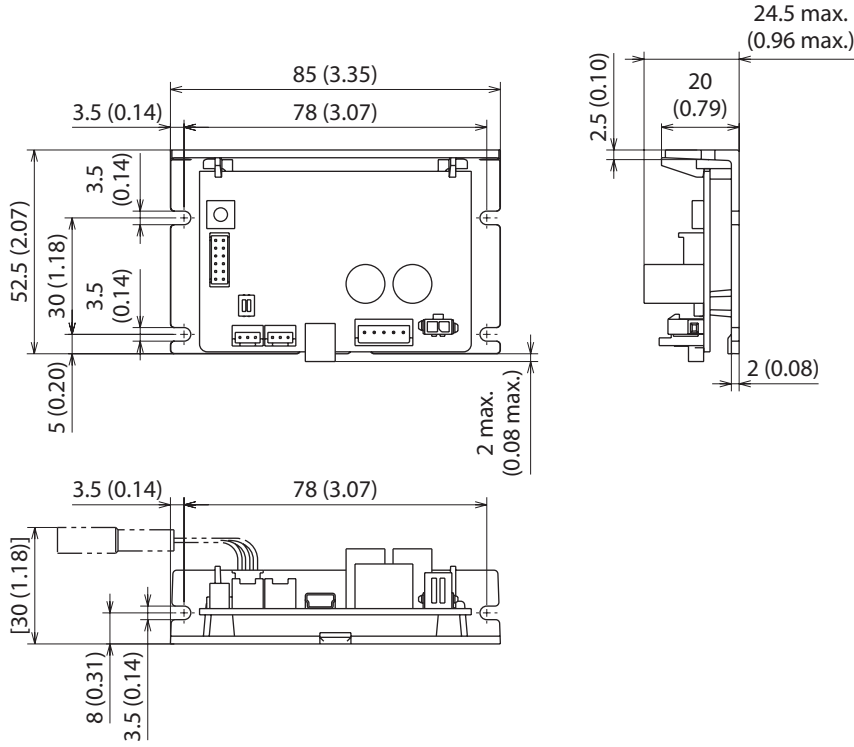

● **When the connector shape is "Right angle"**

Mass: 0.065 kg (2.3 oz.)

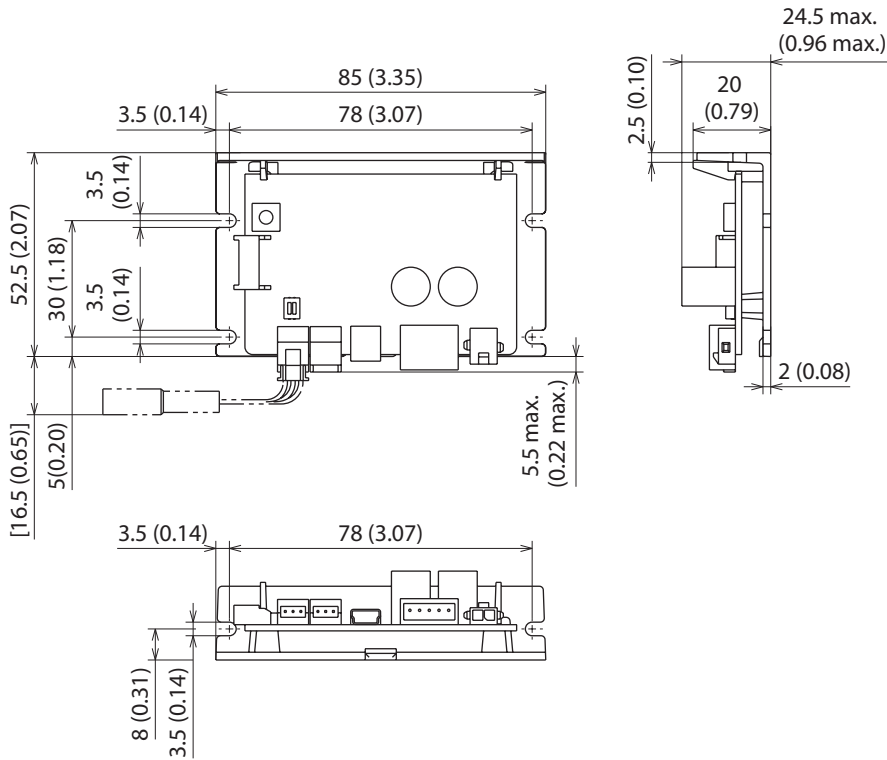

STEP 3 Connection

■ Connection example

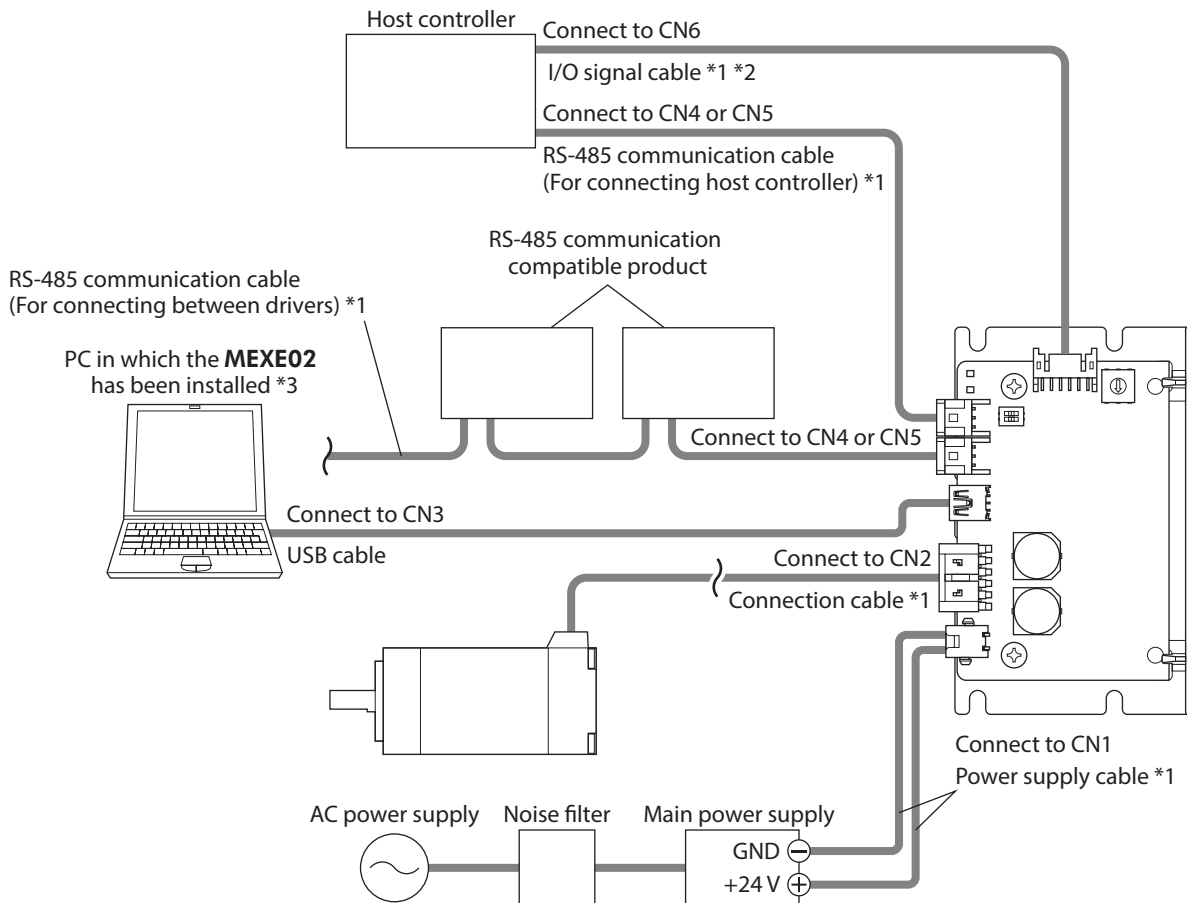

How to use

- *1 These cables are provided as our products.
- *2 Connect when using direct I/O or sensors.
- *3 The PC must be supplied by the customer.

- Note**
- When connecting, pay attention to the polarity of the main power supply. Reverse-polarity connection may cause damage to the driver.
 - Connect the connectors securely. Insecure connections may cause malfunction or damage to the driver.

- memo**
- When disconnecting the connector, pull out while pressing the latches on the connector with fingers.
 - When turning on the main power supply again or connecting/disconnecting the connector, turn off the main power supply and wait for the PWR/ALM LED to turn off.
 - Separate an I/O signal cable at least 100 mm (3.94 in.) from inductance loads such as electromagnetic relays, and wire so that it is not in parallel with power supply cables and connection cables.
 - Do not wire the power supply cable of the driver in the same cable duct with other power lines or connection cables.
 - If the connection cable or power supply cable generates an undesirable amount of noise depending on the installation and wiring, shield the cable or install a ferrite core.
 - Up to three pieces of cables can be used to connect between a motor and a driver. Keep 10 m (32.8 ft.) or less for the wiring distance between the motor and the driver.
 - Keep 10 m (32.8 ft.) or less for the total wiring distance of the RS-485 communication cable. To extend more than 10 m (32.8 ft.) causes the driver to be affected easily by electrical noise.

3-1 Connecting the motor (CN2): 2-phase stepping motor

Connector pin assignments vary depending on the motor. Refer to the table when connecting. "Color" in the table shows the colors of lead wires of our connection cable. The pin number is shown in the figure.

Note The motors of the Model A and Model B are different in pin assignments. The motor does not rotate properly if the connection is wrong.

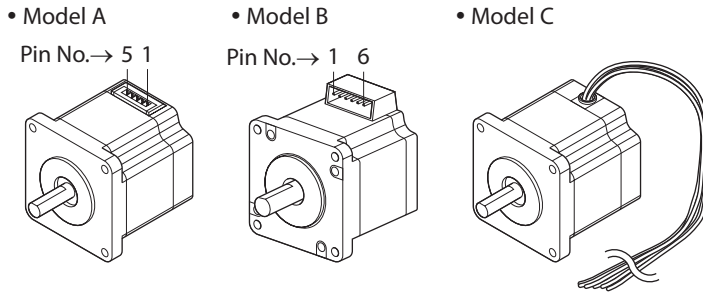

Pin assignment

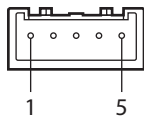

Driver CN2 pin No.	Model A		Model B		Model C
	Pin No.	Color	Pin No.	Color	Color
1	4	Blue	1	Blue	Blue
2	5	Red	3	Red	Red
3	-		-		-
4	2	Green	6	Green	Green
5	1	Black	4	Black	Black

Applicable connector

Manufacturer	Molex, LLC
Connector housing	51103-0500
Contact	50351-8100
Designated crimping tool	63811-8100
Applicable lead wire	<ul style="list-style-type: none"> • AWG24 to 22 (0.2 to 0.3 mm²) * • Outer sheath diameter: \varnothing1.15 to 1.8 mm (\varnothing0.045 to 0.071 in.) • Stripping length of wire insulation: 2.3 to 2.8 mm (0.091 to 0.11 in.)

* If a motor whose motor setting switch (SW1) is set to "A" is used, use the lead wires of AWG22 (0.3 mm²). Refer to p.25 for the motor setting switch.

Motors of frame size 20 mm (0.79 in.)

When motors of the frame size 20 mm (0.79 in.) (PKP213, PKP214) are used, connect by relaying lead wires of AWG24 to AWG22 (0.2 to 0.3 mm²) since the wire diameter of the motor lead wires is as small as AWG26 (0.14 mm²). Connection cables (without termination processing) provided by us can also be used. Refer to p.48 for the model name.

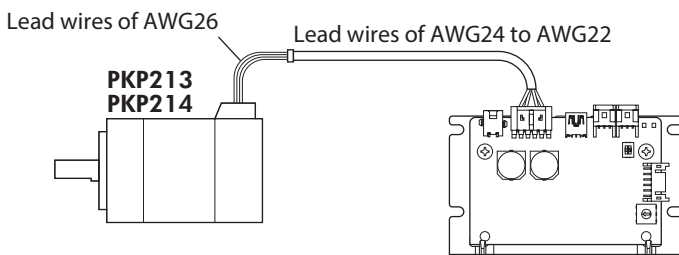

3-2 Connecting the motor (CN2): 5-phase stepping motor and motorized actuator

Connector pin assignments vary depending on the motor. Refer to the table when connecting. "Color" in the table shows the colors of lead wires of our connection cable. The pin number is shown in the figure.

Note The motors of the Model A and Model B are different in pin assignments. The motor does not rotate properly if the connection is wrong.

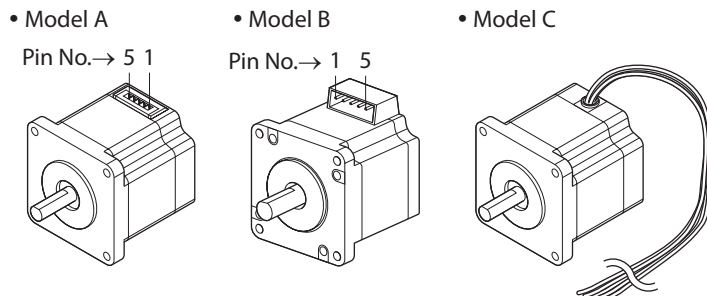

Pin assignment

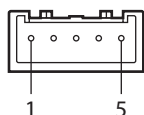

Driver CN2 pin No.	Model A		Model B		Model C
	Pin No.	Color	Pin No.	Color	Color
1	5	Blue	1	Blue	Blue
2	4	Red	2	Red	Red
3	3	Orange	3	Orange	Orange
4	2	Green	4	Green	Green
5	1	Black	5	Black	Black

Applicable connector

Manufacturer	Molex, LLC
Connector housing	51103-0500
Contact	50351-8100
Designated crimping tool	63811-8100
Applicable lead wire	<ul style="list-style-type: none"> • AWG24 to 22 (0.2 to 0.3 mm²) * • Outer sheath diameter: ø1.15 to 1.8 mm (ø0.045 to 0.071 in.) • Stripping length of wire insulation: 2.3 to 2.8 mm (0.091 to 0.11 in.)

* If a motor whose motor setting switch (SW1) is set to "7" is used, use the lead wires of AWG22 (0.3 mm²). Refer to p.26 for the motor setting switch.

How to use

3-3 Connecting the main power supply (CN1)

■ Power supply current capacity

- The current capacity of the main power supply varies depending on the product to be combined.
- Models in the table describe part of the entire name of models.
The box (□) in the model name indicates a number representing the motor length.
The box (■) in the model name indicates **A** (single shaft) or **B** (double shaft) representing the shape.

● 2-phase stepping motor

Model	Input power supply voltage	Power supply current capacity
PKP213D05■ PKP214D06■	24 VDC±10 %	0.5 A or more
PKP22□D15■ PKP22□D15■2 PKP22□MD15■ PKP23□D15■		1.9 A or more
PKP23□D23■		2.0 A or more
PKP24□D08■2		0.8 A or more
PKP24□D15■		1.9 A or more
PKP24□D15■2		1.4 A or more
PKP24□D23■ PKP24□D23■2		2.0 A or more
PKP24□MD15■		1.9 A or more
PKP24□MD15■2		1.4 A or more
PKP25□D28■A2		3.0 A or more
PKP262FD15A		1.9 A or more
PKP26□D14■2		1.3 A or more
PKP26□D28■ PKP26□D28■2 PKP26□MD28■ PKP26□MD28■2		3.0 A or more

● 5-phase stepping motor

Model	Input power supply voltage	Power supply current capacity
PK513	24 VDC±10 %	0.6 A or more
PK52□H		1.4 A or more
PK52□P		0.6 A or more
PK54□		1.4 A or more
PK56□		1.8 A or more
PKP52□N12		1.7 A or more
PKP52□N03 PKP52□MN03		0.6 A or more
PKP52□N07 PKP52□MN07		1.4 A or more
PKP54□MN PKP54□N18■ PKP54□N18■2		2.8 A or more
PKP56□FMN PKP56□FN24■2		3.0 A or more

● Motorized actuator

Model	Input power supply voltage	Power supply current capacity
DHM28PAK2 DHM42PAK	24 VDC±10 %	1.4 A or more
DRLM20		0.6 A or more
DRLM28 DRLM42		1.4 A or more
DRLM60		1.8 A or more

■ Pin assignment

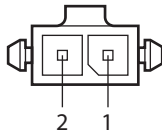

Pin No.	Description
1	+24 VDC Power supply input
2	Power supply GND

■ Applicable connector

Manufacturer	Molex, LLC
Connector housing	43645-0200
Contact	43030-0001
Designated crimping tool	638190000
Applicable lead wire	<ul style="list-style-type: none"> • AWG22 (0.3 mm²) • Outer sheath diameter: ø1.85mm (ø0.073 in.) • Stripping length of wire insulation: 2.54 to 2.92 mm (0.1 to 0.115 in.)



Keep the wiring distance as short as possible [less than 2 m (6.6 ft.)] to suppress the effect of noise.

3-4 Connecting the RS-485 communication compatible product (CN4, CN5)

Connect the RS-485 communication cable to CN4 or CN5 connector. A vacant connector can be used to connect a different driver.

■ Pin assignment

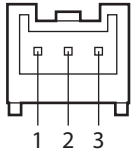

Pin No.	Signal name	Description
1	TR+	RS-485 communication signal (+)
2	TR-	RS-485 communication signal (-)
3	SG	Signal ground

■ Applicable connector

Manufacturer	J.S.T. Mfg. Co., Ltd.
Connector housing	PAP-03V-S
Contact	SPHD-001T-P0.5 or SPHD-002T-P0.5
Designated crimping tool	<ul style="list-style-type: none"> When the contact model is SPHD-001T-P0.5 AWG24 to AWG22: YC-611R AWG26 to AWG24: YC-610R When the contact model is SPHD-002T-P0.5 YRS-620
Applicable lead wire	<ul style="list-style-type: none"> When the contact model is SPHD-001T-P0.5 AWG26 to 22 (0.13 to 0.33 mm²) Outer sheath diameter: ø1 to 1.5 mm (ø0.039 to 0.059 in.) When the contact model is SPHD-002T-P0.5 AWG28 to 24 (0.08 to 0.21 mm²) Outer sheath diameter: ø0.76 to 1.5 mm (ø0.03 to 0.059 in.)

memo Twisted-pair wires or shielded wires are recommended for RS-485 communication cable.

Internal output circuit

SG is insulated from the internal GND.

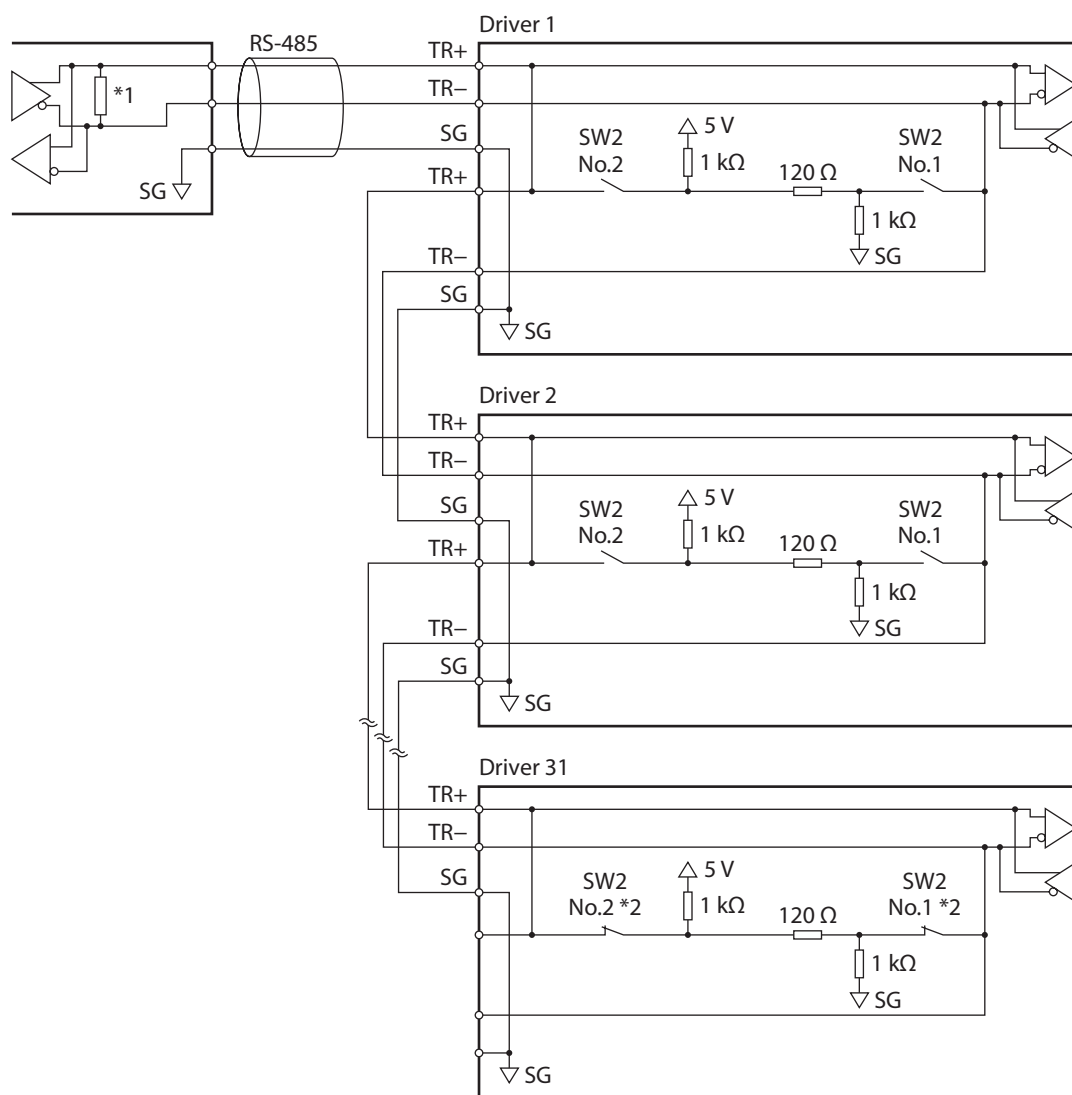

*1 Termination resistor (120 Ω)

*2 Turn the termination resistor to ON.

3-5 Connecting the USB cable (CN3)

Using a USB cable of the following specification, connect a PC in which the **MEXE02** has been installed to the USB communication connector (CN3).

Specification	USB2.0 (full speed)
Cable	Length: 3 m (9.8 ft.) or less Shape: A to mini B



- Connect the driver and PC directly using the USB cable.
- In large electrically noisy environments, use the USB cable with a ferrite core or install a ferrite core to the USB cable.

3-6 Connecting the I/O signals (CN6)

■ Pin assignment

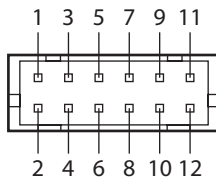

Pin No.	Signal name	Description *
1	IN-COM	Input common
2	IN0	Control input 0 [FW-POS]
3	IN1	Control input 1 [RV-POS]
4	IN2	Control input 2 [STOP]
5	IN3	Control input 3 [ALM-RST]
6	IN4	Control input 4 [HOMES]
7	IN5	Control input 5 [FW-LS]
8	IN6	Control input 6 [RV-LS]
9	OUT0	Control output 0 [ALM-B]
10	OUT1	Control output 1 [TIM]
11	OUT-COM	Output common
12	N.C.	N.C.

* Values in brackets [] are initial values.

■ Applicable connector

Manufacturer	J.S.T. Mfg. Co., Ltd.
Connector housing	PHDR-12VS
Contact	SPHD-001T-P0.5
Designated crimping tool	YC-610R
Applicable lead wire	<ul style="list-style-type: none"> • AWG26 (0.14 mm²) • Outer sheath diameter: ø1 to 1.5 mm (ø0.039 to 0.059 in.)



- Keep the wiring distance as short as possible [less than 2 m (6.6 ft.)] to suppress the effect of noise.
- Twisted-pair wires or shielded wires are recommended for I/O signal cable.

■ Connection example with a current sink output circuit

The value in parentheses () is the initial value.

In this example, signals IN4 to IN6 are connected to sensors. They can also be connected to the host controller.

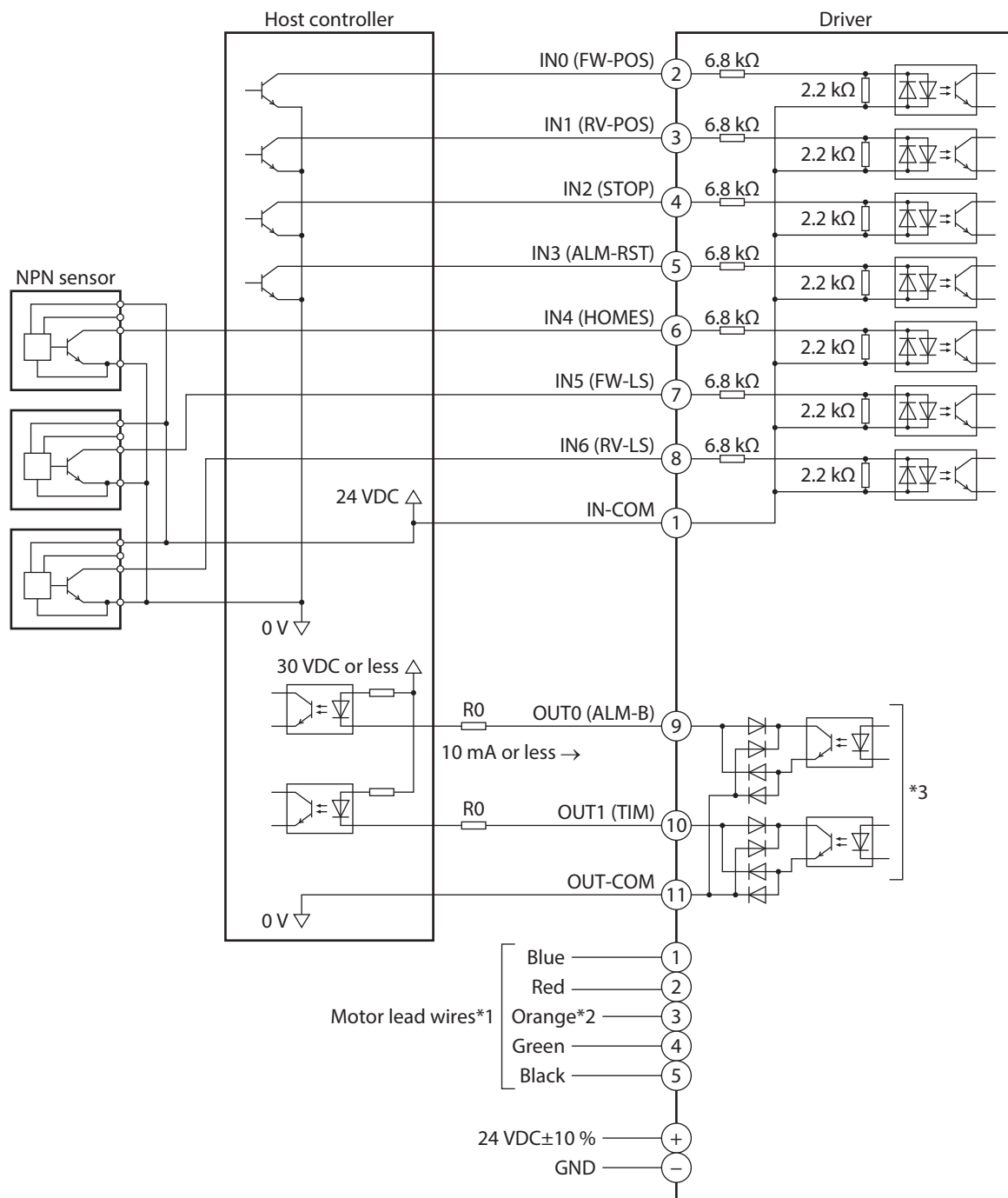

How to use

*1 Connector pin assignments vary depending on the motor. Refer to p.16, p.17 for details.

*2 No lead wire is provided for 2-phase stepping motors. Do not connect anything to the pin No.3.

*3 The saturated voltage of the output signal is 1.2 VDC maximum.

memo Use output signals at 30 VDC 10 mA or less. If the current exceeds 10 mA, connect an external resistor R0 to adjust.

■ Connection example with a current source output circuit

The value in parentheses () is the initial value.

In this example, signals IN4 to IN6 are connected to sensors. They can also be connected to the host controller.

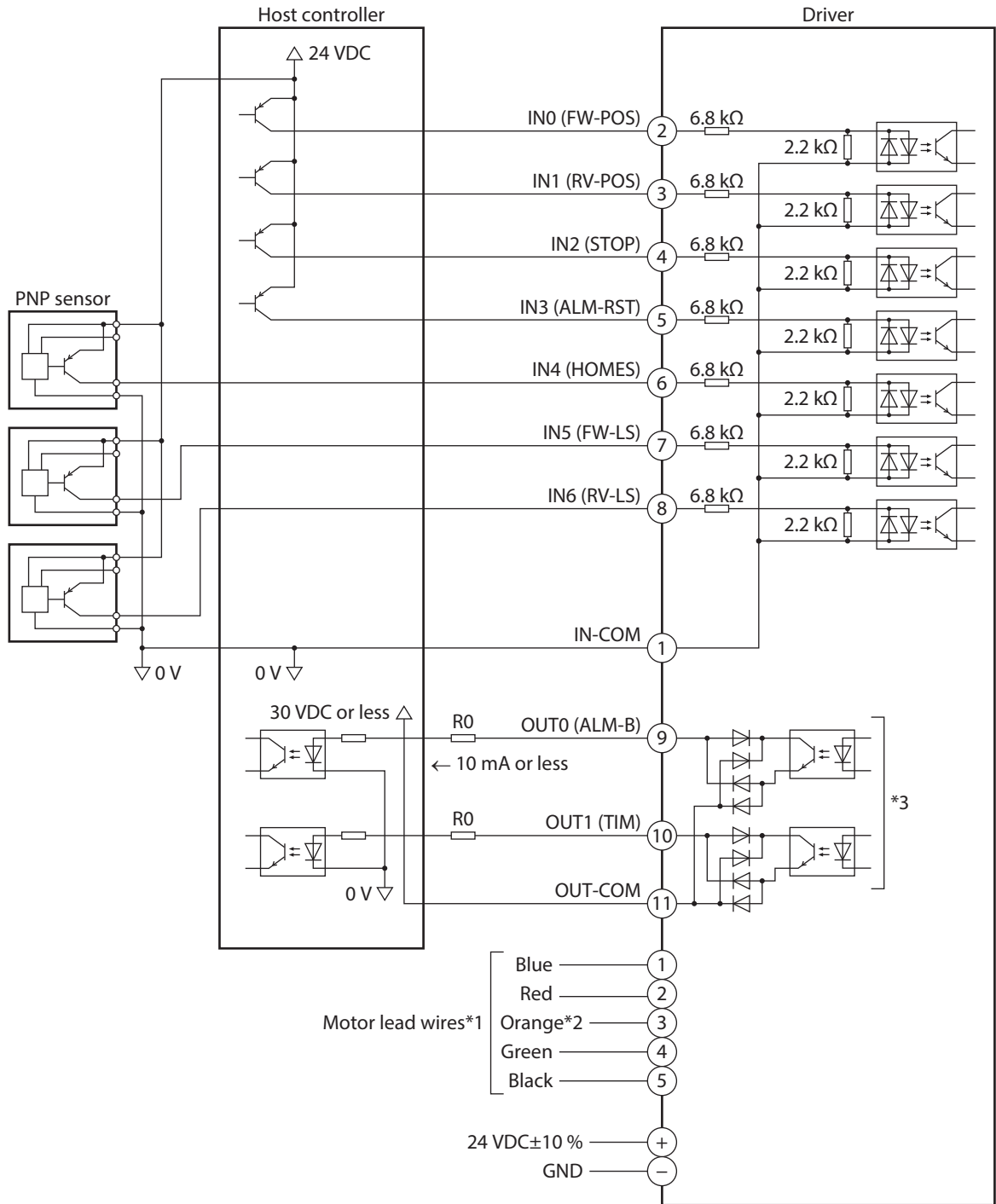

*1 Connector pin assignments vary depending on the motor. Refer to p.16, p.17 for details.

*2 No lead wire is provided for 2-phase stepping motors. Do not connect anything to the pin No.3.

*3 The saturated voltage of the output signal is 1.2 VDC maximum.

memo Use output signals at 30 VDC 10 mA or less. If the current exceeds 10 mA, connect an external resistor R0 to adjust.

STEP 4 Setting the applicable product

Set the motor setting switch (SW1) according to the product combined.
If the switch is set, the output current of the driver is automatically set.

⚠ CAUTION Be sure to set the switch according to the product combined. If the output current of the driver is set to a value higher than the rated current of the product combined by mistake in setting, fire or a skin burn(s) may result.



- Turn off the main power supply of the driver before setting the switch.
- The set switch is enabled after the main power supply is turned on again.
- Setting the switch to a value not shown in the table causes the motor to remain in a non-excitation state, and the information of motor setting error is generated.

■ 2-phase stepping motor

Factory setting 0 (No setting)

Model *	Setting of switch	Output current of driver to be set (A/phase)
PKP213D05■	2	0.5
PKP214D06■	3	0.6
PKP22□D15■ PKP22□D15■2 PKP22□MD15■ PKP23□D15■	6	1.5
PKP23□D23■	8	2.3
PKP24□D08■2	4	0.85
PKP24□D15■ PKP24□MD15■	6	1.5
PKP24□D15■2	7	1.5
PKP24□D23■	8	2.3
PKP24□D23■2	9	2.3
PKP24□MD15■2	7	1.5
PKP25□D28■A2	A	2.8
PKP262FD15A	6	1.5
PKP26□D14■2	5	1.4
PKP26□D28■ PKP26□D28■2 PKP26□MD28■ PKP26□MD28■2	A	2.8

* Model names in the table describe part of the entire name of models.
The box (□) in the model name indicates a number representing the motor length.
The box (■) in the model name indicates **A** (single shaft) or **B** (double shaft) representing the shape.

■ 5-phase stepping motor

Factory setting 0 (No setting)

Model *	Setting of switch	Output current of driver to be set (A/phase)
PK513	2	0.35
PK52□H	3	0.75
PK52□P	2	0.35
PK54□	3	0.75
PK56□	5	1.4
PKP52□N12	4	1.2
PKP52□N03 PKP52□MN03	2	0.35
PKP52□N07 PKP52□MN07	3	0.75
PKP54□MN PKP54□N18■ PKP54□N18■2	6	1.8
PKP56□FMN PKP56□FN24■2	7	2.4

* Model names in the table describe part of the entire name of models.
 The box (□) in the model name indicates a number representing the motor length.
 The box (■) in the model name indicates **A** (single shaft) or **B** (double shaft) representing the shape.

■ Motorized actuator

Factory setting 0 (No setting)

Model *	Setting of switch	Output current of driver to be set (A/phase)
DHM28PAK2 DHM42PAK	3	0.75
DRLM20	2	0.35
DRLM28 DRLM42	3	0.75
DRLM60	5	1.4

* Model names in the table describe part of the entire name of models.

STEP 5 Settings related to RS-485 communication

5-1 Setting of termination resistor

Set the termination resistor (120 Ω) of RS-485 communication to the driver located the farthest away (positioned at the end) from the host controller.

Set both No.1 and No.2 of the termination resistor setting switch (SW2) to ON.



- Turn off the main power supply of the driver before setting the switch.
- If only one of the two is set to ON, a communication error may occur.

Factory setting OFF for both No.1 and No.2 (termination resistor disabled)

SW2 switch-No.1, No.2	Termination resistor (120 Ω)
Both are OFF	Disabled
Both are ON	Enabled

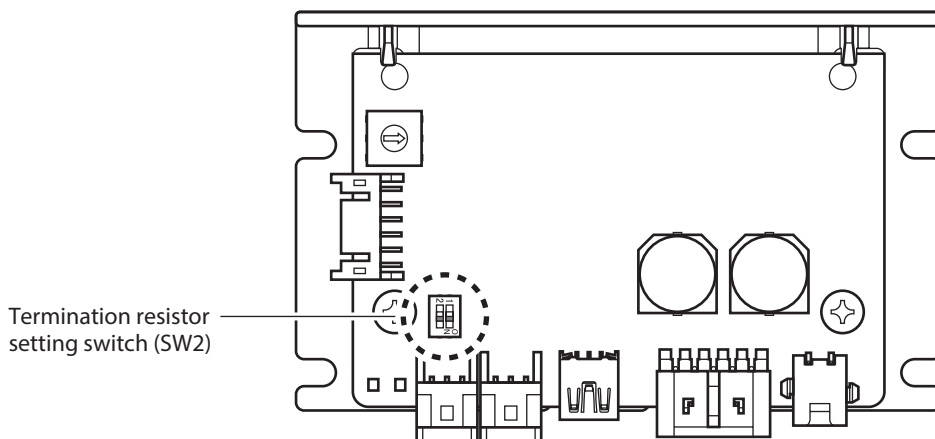

5-2 Setting of communication parameters

Set parameters required for RS-485 communication before performing communication.

■ Parameters updated when turning on the main power supply

These are parameters related to sending/receiving via RS-485 communication. Parameters are recommended to set using the **MEXE02**.

When having changed the setting or initialized, turn off the main power supply and turn on it again. These parameters are exempt from configuration.

MEXE02 code	Register address		Name	Description	Initial value
	Upper	Lower			
p10	1380h (4992)	1381h (4993)	Server address (Modbus)	Sets the address number (server address). [Setting range] ID=1 to ID=31: Server address* * Do not use 0.	1
	1382h (4994)	1383h (4995)	Baudrate (Modbus)	Sets the transmission rate. [Setting range] 0: 9,600 bps 1: 19,200 bps 2: 38,400 bps 3: 57,600 bps 4: 115,200 bps 5: 230,400 bps	4
	1384h (4996)	1385h (4997)	Byte and word order (Modbus)	Sets the byte order of 32-bit data. Set it when the arrangement of the communication data is different from that of the host controller. (Setting example ⇨ "Setting example of the "Byte & word order (Modbus)" parameter" on p.29) [Setting range] 0: Even Address-High Word & Big-Endian 1: Even Address-Low Word & Big-Endian 2: Even Address-High Word & Little-Endian 3: Even Address-Low Word & Little-Endian	0
	1386h (4998)	1387h (4999)	Communication parity (Modbus)	Sets the communication parity. [Setting range] 0: None 1: Even parity 2: Odd parity	1
	1388h (5000)	1389h (5001)	Communication stop bit (Modbus)	Sets the communication stop bit. [Setting range] 0: 1 bit 1: 2 bits	0
	138Eh (5006)	138Fh (5007)	Transmission waiting time (Modbus)	Sets the transmission waiting time. [Setting range] 0 to 10,000 (1=0.1 ms)	30
	1390h (5008)	1391h (5009)	Silent interval (Modbus)	Sets the silent interval. [Setting range] 0 (automatically set), 1 to 100 (1=0.1 ms)	0



To initialize parameters in the table, perform one of the following.

- Perform "All data batch initialization" of the maintenance command.
If the initial value of the driver is different from the value set in the host controller, communication cannot be performed. Therefore, match the setting between the driver and the host controller after initialization.
- Perform "Reset" of the **MEXE02**.

Setting example of the “Byte & word order (Modbus)” parameter

When 32-bit data “12345678h” is stored at the register addresses 1000h and 1001h, arrangement is changed as follows depending on the setting of parameters.

Setting of parameters	1000h (even address)		1001h (odd address)	
	Upper	Lower	Upper	Lower
0: Even Address-High Word & Big-Endian	12h	34h	56h	78h
1: Even Address-Low Word & Big-Endian	56h	78h	12h	34h
2: Even Address-High Word & Little-Endian	34h	12h	78h	56h
3: Even Address-Low Word & Little-Endian	78h	56h	34h	12h

■ Parameters updated immediately after rewriting

Set the following parameters via RS-485 communication or using the **MEXE02**.

MEXE02 code	Register address		Name	Description	Initial value
	Upper	Lower			
p10	138Ah (5002)	138Bh (5003)	Communication timeout (Modbus)	Sets the generation condition of the communication timeout. [Setting range] 0 (not monitored), 1 to 10,000 ms	0
	138Ch (5004)	138Dh (5005)	Communication error detection (Modbus)	When the RS-485 communication error has occurred for the set number of times, an alarm of RS-485 communication error is generated. [Setting range] 0 (disable), 1 to 10 times	3
	1392h (5010)	1393h (5011)	Server error response mode (Modbus)	Sets the response when a server error occurs. [Setting range] 0: As normal response 1: As exception response	1

4 Inspection and maintenance

4-1 Inspection

It is recommended that periodic inspections are conducted for the items listed below after each operation of the motor. If an abnormal condition is noted, discontinue any use and contact your nearest Oriental Motor sales office.

■ Inspection item

- Check if the installation place of the driver is loose.
- Check if any of the connection parts of the connector is loose.
- Check if dust and others attach on the driver.
- Check if the driver has unusual smells or appearance defects.

Note The driver uses semiconductor components. Static electricity may damage the semiconductor components of the driver, so be extremely careful when handling the driver.

4-2 Warranty

Check on the Oriental Motor Website for the product warranty.

4-3 Disposal

Dispose the product correctly in accordance with laws and regulations, or instructions of local governments.

5 Alarms

This driver has the alarm function to protect from temperature rise, poor connection, error in operation, and others. If an alarm is generated, the ALM-A output is turned ON and the ALM-B output is turned OFF to stop the motor. At the same time, the PWR/ALM LED blinks in red.

The present alarm can be checked by counting the number of times the LED blinks, via RS-485 communication, or using the **MEXE02**.

5-1 Alarm reset

Before resetting an alarm, always remove the cause of the alarm and ensure safety, and perform one of the reset operations specified next.

- Execute the alarm reset of the maintenance command via RS-485 communication.
- Execute the alarm reset using the **MEXE02**.
- Turn the ALM-RST input ON. (It is enabled at the ON edge of the input.) (Timing chart ⇨ p.37)
- Turn on the main power supply again.



Some alarms cannot be reset by other methods than turning on the main power supply again. Check with "5-3 Alarm list" on p.32.

5-2 Alarm history

Up to 10 generated alarm items are stored in the non-volatile memory in order of the latest to oldest. The alarm history stored in the non-volatile memory can be read or cleared if one of the following is performed.

- Read the alarm history by the monitor command via RS-485 communication.
- Clear the alarm history by the maintenance command via RS-485 communication.
- Read or clear the alarm history using the **MEXE02**.

5-3 Alarm list

Alarm code	Number of times LED blinks	Alarm type	Cause	Remedial action	Reset using the ALM-RST input	Motor excitation *
20h	5	Overcurrent	The motor, the cable, and the driver output circuit were short-circuited.	Turn off the main power supply first, and check the motor, the cable, and the driver are not damaged. After that, turn on the main power supply again. If the alarm is still not reset, the motor, the cable, or the driver may be damaged. Contact your nearest Oriental Motor sales office.	Not possible	Non-excitation
21h	2	Main circuit overheat	The board temperature of the driver exceeded 85 °C (185 °F).	Reconsider the ventilation condition.	Possible	Non-excitation
22h	3	Overvoltage	<ul style="list-style-type: none"> The power supply voltage exceeded 43.1 VDC. A large load inertia was suddenly stopped. Vertical operation (elevating operation) was performed. 	<ul style="list-style-type: none"> Check the input voltage of the main power supply. Decrease the load. Increase the acceleration/ deceleration time or slow the acceleration/ deceleration rate. 	Possible	Non-excitation
25h	3	Undervoltage	The main power supply was shut off momentarily or a voltage shortage was generated.	Check the input voltage of the main power supply.	Possible	Non-excitation
34h	2	Command pulse error	The frequency of the command pulse exceeded 9,600 r/min.	Decrease the frequency of the command pulse.	Possible	Non-excitation
41h	9	EEPROM error	The data stored in the driver was damaged.	Initialize all parameters.	Not possible	Non-excitation
4Ah	7	Return-to-home incomplete	Absolute positioning operation was started in a state where the position coordinate had not been set.	Execute the position preset or return-to-home operation.	Possible	Excitation
60h	7	±LS both sides active	<ul style="list-style-type: none"> When the "FW-LS/RV-LS input action" parameter is set to "2: Immediate stop with alarm" or "3: Deceleration stop with alarm," both the FW-LS input and the RV-LS input were detected. Return-to-home operation was executed in a state where both the FW-LS input and RV-LS input were detected. 	Check the sensor logic installed and the "Inverting mode" parameter.	Possible	Excitation

Alarm code	Number of times LED blinks	Alarm type	Cause	Remedial action	Reset using the ALM-RST input	Motor excitation *
61h	7	Reverse \pm LS connection	The LS input opposite to the operating direction was detected while return-to-home operation in 2-sensor mode or 3-sensor mode was performed.	Check the wiring of the sensor.	Possible	Excitation
62h	7	Return-to-home operation error	<ul style="list-style-type: none"> The installation positions of the FW-LS and RV-LS sensors and the HOME sensor are near to each other. The motor exceeded the HOME sensor at decelerating to a stop while return-to-home operation in one-way rotation mode was performed. 	<ul style="list-style-type: none"> Reconsider the sensor installation positions and the starting direction of motor operation. Reconsider the specification of the HOME sensor and the "(HOME) Acceleration/ deceleration" parameter. 	Possible	Excitation
63h	7	No HOMES	The HOMES input was not detected at a position between the FW-LS input and the RV-LS input while return-to-home operation in 3-sensor mode was performed.	Install the HOME sensor at a position between the FW-LS and RV-LS sensors.	Possible	Excitation
64h	7	TIM, SLIT signal error	None of the TIM output or the SLIT input could be detected during return-to-home operation.	<ul style="list-style-type: none"> Reconsider the connection status of the load and the position of the HOME sensor so that these signals should be ON while the HOMES input is ON. When a signal is not used, set the "(HOME) TIM signal detection" parameter or the "(HOME) SLIT detection" parameter to "0: Disable." 	Possible	Excitation
66h	7	Hardware overtravel	When the "FW-LS/RV-LS input action" parameter is set to "2: Immediate stop with alarm" or "3: Deceleration stop with alarm," the FW-LS input or the RV-LS input was detected.	Reset the alarm and then escape from the sensor by operating the motor or manually.	Possible	Excitation
67h	7	Software overtravel	When the "Software overtravel" parameter is set to "2: Immediate stop with alarm" or "3: Deceleration stop with alarm," the motor position reached the set value of the software limit.	<ul style="list-style-type: none"> Reconsider the operation data. Reset the alarm and then escape from the sensor by operating the motor or manually. 	Possible	Excitation

Alarm code	Number of times LED blinks	Alarm type	Cause	Remedial action	Reset using the ALM-RST input	Motor excitation *
6Ah	7	Return-to-home operation offset error	When offset movement as part of return-to-home operation is performed, the FW-LS input or the RV-LS input was detected.	Check the offset value.	Possible	Excitation
70h	7	Operation data error	Positioning SD operation was performed with data whose operating speed was 0.	Check the operation data. (Sub codes of the operation data error → p.35)	Possible	Excitation
84h	7	RS-485 communication error	The number of consecutive RS-485 communication errors reached the value set in the "Communication error detection" parameter.	<ul style="list-style-type: none"> • Check the connection between the host controller and driver. • Check the setting of RS-485 communication. 	Possible	Excitation
85h	7	RS-485 communication timeout	The time set in the "Communication timeout" parameter has elapsed, and yet the communication could not be established with the host controller.	Check the connection between the host controller and driver.	Possible	Excitation
F0h	Light	CPU error	CPU malfunctioned.	Turn on the main power supply again.	–	–

* The motor excitation when an alarm is generated is as follows.

Non-excitation: If an alarm is generated, the motor current is cut off and the motor holding force is lost.

Excitation: Even if an alarm is generated, the motor current is not cut off and the motor position is held.

5-4 Monitor of alarm history

The alarm history can be checked via RS-485 communication or using the **MEXE02**. The operation executed when the alarm was generated and the status of I/O signal are also recorded.

Related command

Register address		Name	Description
Upper	Lower		
01AAh (426)	01ABh (427)	Alarm history details	When a history number (1 to 10) is written to this command and the monitor command "Alarm history details" is executed, the detailed items of the specified alarm history can be checked.

■ Items that can be checked in the alarm history

Register address		Name	Description
Upper	Lower		
0A00h (2560)	0A01h (2561)	Alarm history details (alarm code)	Shows the alarm code.
0A02h (2562)	0A03h (2563)	Alarm history details (sub code)	Our code for checking. However, when the operation data error (alarm code 70h) was generated, you can check the cause of the alarm by yourself using the sub code. For details about sub code, refer to the following table.
0A04h (2564)	0A05h (2565)	Alarm history details (driver temperature)	Shows the driver temperature when an alarm was generated.
0A08h (2568)	0A09h (2569)	Alarm history details (inverter voltage)	Shows the inverter voltage when an alarm was generated.
0A0Ah (2570)	0A0Bh (2571)	Alarm history details (physical I/O input)	Shows the status of direct I/O in hexadecimal when an alarm was generated. (Details of bits ⇨ p.36)
0A0Ch (2572)	0A0Dh (2573)	Alarm history details (R-I/O output)	Shows the status of R-OUT in hexadecimal when an alarm was generated. (Details of bits ⇨ p.36)
0A0Eh (2574)	0A0Fh (2575)	Alarm history details (operation information 0)	Shows the operation data number executed when an alarm was generated. (⇨ p.36)
0A10h (2576)	0A11h (2577)	Alarm history details (operation information 1)	Shows the operation in a number being executed when an alarm was generated. (⇨ p.36)
0A12h (2578)	0A13h (2579)	Alarm history details (command position)	Shows the command position of the motor when an alarm was generated.
0A14h (2580)	0A15h (2581)	Alarm history details (elapsed time from boot)	Shows the elapsed time after the main power supply was turned on until an alarm was generated.
0A16h (2582)	0A17h (2583)	Alarm history details (elapsed time from starting operation)	Shows the elapsed time after the operation was started until an alarm was generated.
0A18h (2584)	0A19h (2585)	Alarm history details (main power supply time)	Shows the elapsed time after the main power supply was turned on first time until an alarm was generated.



The R-I/O output is monitored internally even if RS-485 communication is not used. If the output signal to be monitored is assigned to the R-OUT output, the number of monitors when an alarm is generated can be increased.

● Sub codes of the operation data error (alarm code 70h)

Sub code	Causes of alarm
01h	Positioning operation was executed with setting the travel amount to "less than -2,147,483,647 steps" or "larger than 2,147,483,647 steps."
03h	Positioning operation was executed in a state where the travel amount was other than 0 step and the speed was 0 Hz.

● **Details of bits for physical I/O input**

The value in brackets [] are initial values.

Bit7	Bit6	Bit5	Bit4	Bit3	Bit2	Bit1	Bit0
—	DIN6 [RV-LS]	DIN5 [FW-LS]	DIN4 [HOMES]	DIN3 [ALM-RST]	DIN2 [STOP]	DIN1 [RV-POS]	DIN0 [FW-POS]

● **Details of bits for R-I/O output**

The value in brackets [] are initial values.

Bit15	Bit14	Bit13	Bit12	Bit11	Bit10	Bit9	Bit8
R-OUT15 [CONST-OFF]	R-OUT14 [CONST-OFF]	R-OUT13 [MOVE]	R-OUT12 [TIM]	R-OUT11 [CONST-OFF]	R-OUT10 [AREA1]	R-OUT9 [AREA0]	R-OUT8 [SYS-BSY]
Bit7	Bit6	Bit5	Bit4	Bit3	Bit2	Bit1	Bit0
R-OUT7 [ALM-A]	R-OUT6 [INFO]	R-OUT5 [READY]	R-OUT4 [HOME-END]	R-OUT3 [START_R]	R-OUT2 [M2_R]	R-OUT1 [M1_R]	R-OUT0 [M0_R]

● **Information shown in “Operation information 0” and “Operation information 1”**

Operation information 0	–1: Operation data not used (*1), or immediately after turning on the main power supply 0 to 255: Operation data number in operation *2
Operation information 1	0: No internal oscillation (being stopped) 1: Stored data operation 2: Direct data operation 3: Return-to-home operation 5: JOG operation 6: High-speed JOG operation 8: Inching operation 9: Continuous operation 13: Teaching, remote operation

*1 Operation other than stored data operation or continuous macro operation is being executed.

*2 The operation data number operated just before stopping is monitored while the operation is stopped.

5-5 Timing chart

■ When the motor remains in an excitation state even if an alarm is generated

1. If an error occurs, the ALM-B output and the MOVE output are turned OFF.
At the same time, the motor stops immediately.
2. Remove the cause of the alarm and then turn the ALM-RST input ON.
The alarm is reset, and the ALM-B output and the READY output are turned ON.
3. Check the ALM-B output has been turned ON and then turn the ALM-RST input OFF.

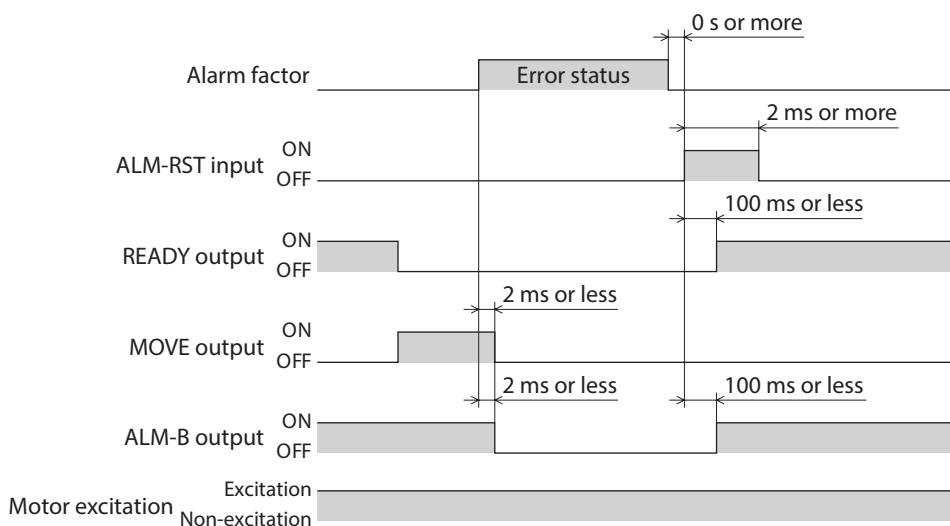
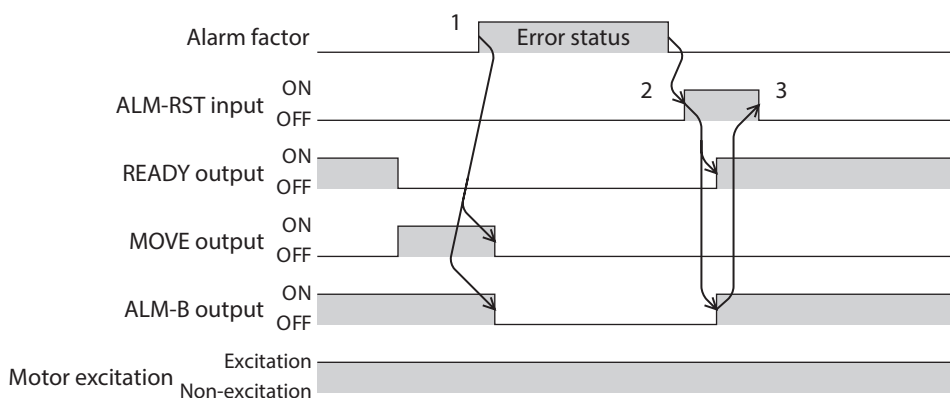

Measures for various cases

■ **When the motor puts into a non-excitation state if an alarm is generated**

1. If an error occurs, the ALM-B output and the MOVE output are turned OFF. At the same time, the motor stops immediately.
2. Remove the cause of the alarm and then turn the ALM-RST input ON. The alarm is reset, and the ALM-B output and the READY output are turned ON.
3. Check the ALM-B output has been turned ON and then turn the ALM-RST input OFF.

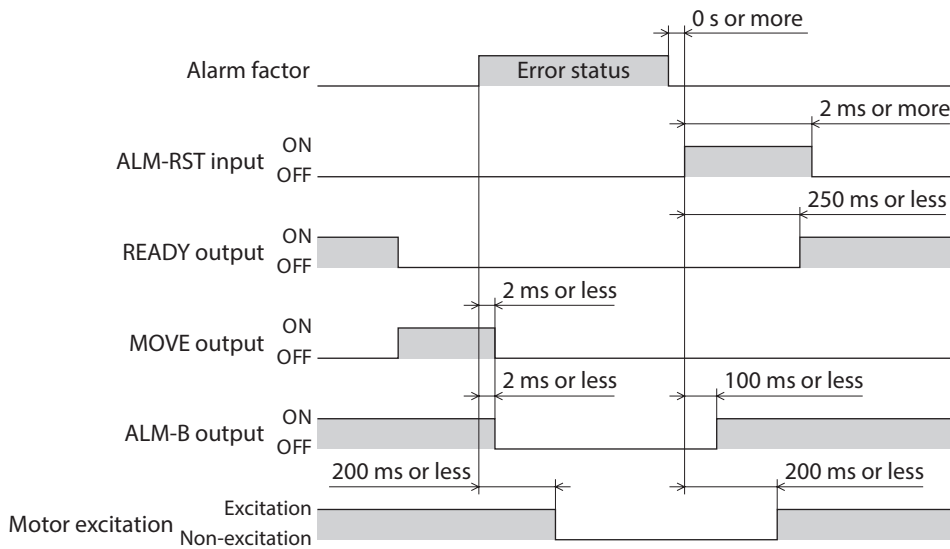
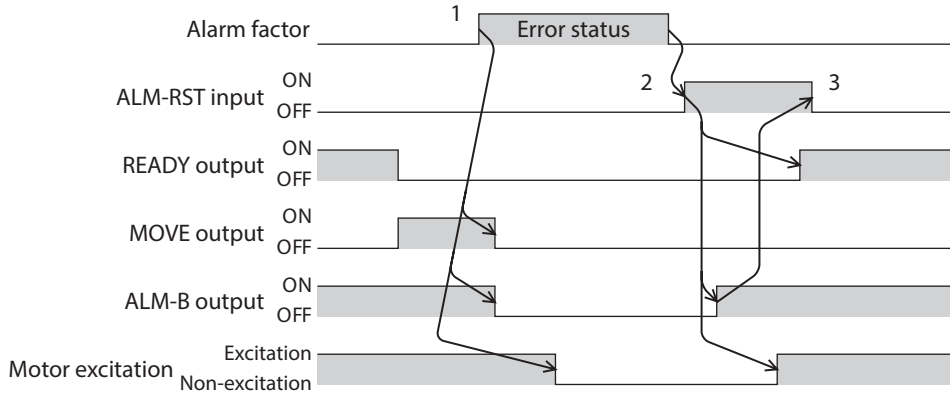

6 Information

The driver is equipped with a function to generate information output before an alarm is generated. This function can be utilized for periodic maintenance of equipment by setting a suitable value in the parameter of each information.

For example, setting the "Tripmeter information" parameter can utilize as a reference to perform maintenance every time a certain rotation amount is reached.

■ Status when information is generated

● Information bit output

If information is generated, a bit output (INFO-** output) of the corresponding information is turned ON.

● INFO output

If information is generated, the INFO output is turned ON.

● LED indicator

If information is generated, the PWR/ALM LED will simultaneously blink in red and green twice. (Red and green colors may overlap and it may be visible to orange.)

● Motor operation

The motor continues to operate during information unlike in the case of an alarm.

● Parameter

Each information has a corresponding "INFO action" parameter. If the parameter is set to "0: No info reflect (Only the bit output is ON.)," only the bit output of information is turned ON, and the INFO output and LED are not changed.

Related parameters

MEXE02 code	Register address		Name	Description	Initial value
	Upper	Lower			
p5	0340h (832)	0341h (833)	Driver temperature information (INFO-DRVTMP)	Sets the generation condition of the driver temperature information (INFO-DRVTMP). [Setting range] 40 to 85 °C	85
	0356h (854)	0357h (855)	Overvoltage information (INFO-OVOLT)	Sets the generation condition of the overvoltage information (INFO-OVOLT). [Setting range] 180 to 430 (1=0.1 V)	430
	0358h (856)	0359h (857)	Undervoltage information (INFO-UVOLT)	Sets the generation condition of the undervoltage information (INFO-UVOLT). [Setting range] 180 to 430 (1=0.1 V)	180
	035Eh (862)	035Fh (863)	Tripmeter information (INFO-TRIP)	Sets the generation condition of the tripmeter information (INFO-TRIP). [Setting range] 0 (disable), 1 to 2,147,483,647 (1=0.1 kRev)	0
	0360h (864)	0361h (865)	Odometer information (INFO-ODO)	Sets the generation condition of the odometer information (INFO-ODO). [Setting range] 0 (disable), 1 to 2,147,483,647 (1=0.1 kRev)	0
	037Ch (892)	037Dh (893)	Information LED condition	Sets the status of the LED when information is generated. [Setting range] 0: Disable (LED does not blink) 1: Enable (LED blinks)	1

MEXE02 code	Register address		Name	Description	Initial value
	Upper	Lower			
p5	037Eh (894)	037Fh (895)	Information auto clear	When the cause of information is eliminated, the INFO output and the bit output of the corresponding information are turned OFF automatically. [Setting range] 0: Disable (not turned OFF automatically) 1: Enable (turned OFF automatically)	1
	0F44h (3908)	0F45h (3909)	INFO action (driver temperature information (INFO-DRVTMP))	Sets the bit output, INFO output, and the status of the LED when information is generated. [Setting range] 0: No info reflect (Only the bit output is ON.) 1: Info reflect (The bit output and the INFO output are ON and the LED blinks.)	1
	0F48h (3912)	0F49h (3913)	INFO action (overvoltage information (INFO-OVOLT))		
	0F4Ah (3914)	0F4Bh (3915)	INFO action (undervoltage information (INFO-UVOLT))		
	0F52h (3922)	0F53h (3923)	INFO action (operation start error information (INFO-START))		
	0F56h (3926)	0F57h (3927)	INFO action (PRESET request information (INFO-PR-REQ))		
	0F58h (3928)	0F59h (3929)	INFO action (motor setting error information (INFO-MSET-E))		
	0F5Eh (3934)	0F5Fh (3935)	INFO action (RS-485 communication error information (INFO-NET-E))		
	0F60h (3936)	0F61h (3937)	INFO action (forward operation prohibition information (INFO-FW-OT))		
	0F62h (3938)	0F63h (3939)	INFO action (reverse operation prohibition information (INFO-RV-OT))		
	0F68h (3944)	0F69h (3945)	INFO action (tripmeter information (INFO-TRIP))		
	0F6Ah (3946)	0F6Bh (3947)	INFO action (odometer information (INFO-ODO))		
	0F78h (3960)	0F79h (3961)	INFO action (operation start restricted mode information (INFO-DSLMTD))		
	0F7Ah (3962)	0F7Bh (3963)	INFO action (I/O test mode information (INFO-IOTEST))		
	0F7Ch (3964)	0F7Dh (3965)	INFO action (configuration request information (INFO-CFG))		
	0F7Eh (3966)	0F7Fh (3967)	INFO action (reboot request information (INFO-RBT))		

6-1 Clearing information

How to clear the information can be set with the “Information auto clear” parameter.

- **When the “Information auto clear” parameter is set to “1: Enable (turned off automatically)”**
The generated information will automatically be cleared if the condition to clear information is satisfied.
- **When the “Information auto clear” parameter is set to “0: Disable (not turned off automatically)”**
Even if the condition to clear information is satisfied, the information is kept generated. The information can be cleared if one of the following is performed in a state where the condition to clear information is satisfied.
 - Execute the clear information of the maintenance command via RS-485 communication.
 - Execute the clear information on the information monitor of the **MEXE02**.
 - Turn the INFO-CLR input ON.
 - Turn on the main power supply again.

6-2 Information history

Up to 16 generated information items are stored in the RAM in order of the latest to oldest. Information items stored as the information history are the information code, generation time, and contents of information.

The information history can be read or cleared when one of the following is performed.

- Read the information history by the monitor command via RS-485 communication.
- Clear the information history by the maintenance command via RS-485 communication.
- Read or clear the information history using the **MEXE02**.



Information history is stored in the RAM, so they are cleared when the main power supply of the driver is turned off.

6-3 Information list

Information item	Information bit output signal	Cause	Reset condition
Driver temperature	INFO-DRVTMP	The internal temperature of the driver exceeded the value set in the "Driver temperature information" parameter.	The internal temperature of the driver fell below the value set in the "Driver temperature information" parameter.
Overvoltage	INFO-OVOLT	<ul style="list-style-type: none"> • The voltage of the main power supply exceeded the value set in the "Overvoltage information" parameter. • A large load inertia was suddenly stopped. • Vertical operation (elevating operation) was performed. 	The voltage of the main power supply fell below the value set in the "Overvoltage information" parameter.
Undervoltage	INFO-UVOLT	<ul style="list-style-type: none"> • The voltage of the main power supply fell below the value set in the "Undervoltage information" parameter. • The main power supply was shut off momentarily or a voltage shortage was generated. 	The voltage of the main power supply exceeded the value set in the "Undervoltage information" parameter.
Operation start error	INFO-START	<ul style="list-style-type: none"> • The operation start signal in the direction having been stopped by the FW-BLK input or RV-BLK input was turned ON. • The operation start signal in the direction having been stopped by the FW-LS input or RV-LS input was turned ON. • The operation start signal in the direction having been stopped by the software limit was turned ON. • When operation could not be executed (e.g., the READY output was OFF), the operation start signal was turned ON. 	Operation was started normally.
PRESET request	INFO-PR-REQ	Preset was executed by the position preset or return-to-home operation.	Preset was completed.
Motor setting error	INFO-MSET-E	A value not described in the table of "STEP 4 Setting the applicable product" on p.25 was set.	Set the correct value to the motor setting switch (SW1), and turn on the main power supply again.
RS-485 communication error	INFO-NET-E	A RS-485 communication error was detected.	RS-485 communication was performed normally.
Forward operation prohibition	INFO-FW-OT	<ul style="list-style-type: none"> • The positive software limit was exceeded. • Either the FW-LS input or the FW-BLK input was turned ON. 	The position coordinate of the motor was in the range of the positive software limit, and in addition, both the FW-LS input and the FW-BLK input were turned OFF.
Reverse operation prohibition	INFO-RV-OT	<ul style="list-style-type: none"> • The negative software limit was exceeded. • Either the RV-LS input or the RV-BLK input was turned ON. 	The position coordinate of the motor was in the range of the negative software limit, and in addition, both the RV-LS input and the RV-BLK input were turned OFF.

Information item	Information bit output signal	Cause	Reset condition
Tripmeter	INFO-TRIP	The total amount of rotations of the motor output shaft stored in the driver exceeded the value set in the "Tripmeter information" parameter.	The following operation was performed, and the total amount of rotations of the motor output shaft stored in the driver (tripmeter) fell below the value set in the "Tripmeter information" parameter. <ul style="list-style-type: none"> • The "Tripmeter information" parameter was set again. • The tripmeter was cleared via RS-485 communication or using the MEXE02.
Odometer	INFO-ODO	The cumulative amount of rotations of the motor output shaft stored in the driver exceeded the value set in the "Odometer information" parameter.	The following operation was performed, and the cumulative amount of rotations of the motor output shaft stored in the driver (odometer) fell below the value set in the "Odometer information" parameter. <ul style="list-style-type: none"> • The "Odometer information" parameter was set again.
Operation start restricted mode	INFO-DSLMTD	<ul style="list-style-type: none"> • "Teaching, remote operation" was executed using the MEXE02. • Configuration was executed. • Data was written to the driver from the MEXE02. • "Reset" was executed using the MEXE02. 	<ul style="list-style-type: none"> • Teaching, remote operation was canceled. • Configuration was completed. • Writing data was completed. • Data was restored to the factory setting.
I/O test mode	INFO-IOTEST	<ul style="list-style-type: none"> • "I/O test" was executed with the MEXE02. • Configuration was executed. 	<ul style="list-style-type: none"> • The I/O test mode was canceled. • Configuration was completed.
Configuration request	INFO-CFG	The parameter that required executing the configuration was changed.	Configuration was executed.
Reboot request	INFO-RBT	A parameter required the main power supply to turn on again was changed.	The main power supply was turned on.

6-4 Monitor of information history

The information history can be checked via RS-485 communication or using the **MEXE02**.

■ Items that can be checked in the information history

Register address		Name	Description
Upper	Lower		
0A20h (2592)	0A21h (2593)	Information history 1	Shows the latest information history. When information is generated, the code is displayed also in information history 1 at the same time.
0A22h (2594)	0A23h (2595)	Information history 2	
0A24h (2596)	0A25h (2597)	Information history 3	
0A26h (2598)	0A27h (2599)	Information history 4	
0A28h (2600)	0A29h (2601)	Information history 5	
0A2Ah (2602)	0A2Bh (2603)	Information history 6	
0A2Ch (2604)	0A2Dh (2605)	Information history 7	
0A2Eh (2606)	0A2Fh (2607)	Information history 8	
0A30h (2608)	0A31h (2609)	Information history 9	
0A32h (2610)	0A33h (2611)	Information history 10	
0A34h (2612)	0A35h (2613)	Information history 11	
0A36h (2614)	0A37h (2615)	Information history 12	
0A38h (2616)	0A39h (2617)	Information history 13	
0A3Ah (2618)	0A3Bh (2619)	Information history 14	
0A3Ch (2620)	0A3Dh (2621)	Information history 15	
0A3Eh (2622)	0A3Fh (2623)	Information history 16	Shows the information history. For details about information code, refer to "Information codes" on p.45.
0A40h (2624)	0A41h (2625)	Information time history 1	
0A42h (2626)	0A43h (2627)	Information time history 2	
0A44h (2628)	0A45h (2629)	Information time history 3	
0A46h (2630)	0A47h (2631)	Information time history 4	
0A48h (2632)	0A49h (2633)	Information time history 5	
0A4Ah (2634)	0A4Bh (2635)	Information time history 6	
0A4Ch (2636)	0A4Dh (2637)	Information time history 7	
			Shows the oldest information history.
			Shows the history of the time when the latest information was generated. If information is being generated, the generation time of the information is displayed.
			Shows the history of the time when information was generated.

Register address		Name	Description
Upper	Lower		
0A4Eh (2638)	0A4Fh (2639)	Information time history 8	Shows the history of the time when information was generated.
0A50h (2640)	0A51h (2641)	Information time history 9	
0A52h (2642)	0A53h (2643)	Information time history 10	
0A54h (2644)	0A55h (2645)	Information time history 11	
0A56h (2646)	0A57h (2647)	Information time history 12	
0A58h (2648)	0A59h (2649)	Information time history 13	
0A5Ah (2650)	0A5Bh (2651)	Information time history 14	
0A5Ch (2652)	0A5Dh (2653)	Information time history 15	
0A5Eh (2654)	0A5Fh (2655)	Information time history 16	

● Information codes

Information codes are indicated in eight hexadecimal digits. They can also be read in 32 bits.

If multiple information items are generated, the logical sum (OR) of the information codes is indicated.

Example) When information items of the driver temperature and the overvoltage are generated

Information code of driver temperature: 0000 0004h

Information code of overvoltage: 0000 0010h

Logical sum (OR) of two information codes: 0000 0014h

Information code	Display in 32 bits	Information item
00000004h	0000 0000 0000 0000 0000 0000 0000 0100	Driver temperature
00000010h	0000 0000 0000 0000 0000 0000 0001 0000	Overvoltage
00000020h	0000 0000 0000 0000 0000 0000 0010 0000	Undervoltage
00000200h	0000 0000 0000 0000 0000 0010 0000 0000	Operation start error
00000800h	0000 0000 0000 0000 0000 1000 0000 0000	PRESET request
00001000h	0000 0000 0000 0000 0001 0000 0000 0000	Motor setting error
00008000h	0000 0000 0000 0000 1000 0000 0000 0000	RS-485 communication error
00010000h	0000 0000 0000 0001 0000 0000 0000 0000	Forward operation prohibition
00020000h	0000 0000 0000 0010 0000 0000 0000 0000	Reverse operation prohibition
00100000h	0000 0000 0001 0000 0000 0000 0000 0000	Tripmeter
00200000h	0000 0000 0010 0000 0000 0000 0000 0000	Odometer
10000000h	0001 0000 0000 0000 0000 0000 0000 0000	Operation start restricted mode
20000000h	0010 0000 0000 0000 0000 0000 0000 0000	I/O test mode
40000000h	0100 0000 0000 0000 0000 0000 0000 0000	Configuration request
80000000h	1000 0000 0000 0000 0000 0000 0000 0000	Reboot request

7 Troubleshooting and remedial actions

In motor operation, the motor or driver may not function properly due to an improper setting or wrong connection. When the motor cannot be operated properly, refer to the contents provided in this chapter and take an appropriate remedial action.
If the problem persists, contact your nearest Oriental Motor sales office.

Phenomenon	Possible cause	Remedial action
<ul style="list-style-type: none"> The motor is not excited. The motor output shaft can be moved by hand. 	Connection error of the connection cable or power supply cable.	Check the connections between the driver, the motor and the main power supply.
	The AWO input is being ON.	Turn the AWO input OFF.
	The motor setting switch (SW1) is left in the factory setting.	Set the motor setting switch (SW1), and turn on the main power supply again.
	A value not described in the table of "STEP 4 Setting the applicable product" on p.25 was set.	Set the correct value to the motor setting switch (SW1), and turn on the main power supply again.
The motor does not operate.	A value set in the "Base current" parameter or "Stop current" parameter is too low.	Check the setting of the "Base current" parameter or the "Stop current" parameter. If the motor current value is low, the torque will also be low and the operation will be unstable.
	The STOP input is being ON.	Turn the STOP input OFF.
	The position (travel amount) is not set in the operation data when positioning SD operation is performed.	Check the operation data.
The motor rotates in the direction opposite to the specified direction.	When JOG operation, high-speed JOG operation, or continuous macro operation is performed, input signals to operate the motor in the forward direction and the reverse direction are being ON simultaneously.	Turn both inputs signal of the forward direction and the reverse direction OFF, and then turn either one ON.
	The "Motor rotation direction" parameter is set wrongly.	Check the setting of the "Motor rotation direction" parameter.
The gearhead output shaft rotates in the direction opposite to the motor output shaft.	The geared motor that rotates in the direction opposite to the motor output shaft is used.	<ul style="list-style-type: none"> With the TS geared type, the gearhead output shaft rotates in the direction opposite to the motor output shaft when the gear ratio is 20 or 30. With the SH geared type of the frame size 28 mm (1.10 in.), the gearhead output shaft rotates in the direction opposite to the motor output shaft when the gear ratio is 9, 10, or 18. With the SH geared type of the frame size 42 mm (1.65 in.) and 60 mm (2.36 in.), the gearhead output shaft rotates in the direction opposite to the motor output shaft when the gear ratio is 18 or 36. With the flat type with harmonic gear, the gearhead output shaft rotates always rotates in the direction opposite to the motor output shaft.
Motor operation is unstable.	Connection error in the connection cable or the power supply cable.	Check the connections between the driver, the motor and the main power supply.
	A value set in the "Base current" parameter is too low.	Check the setting of the "Base current" parameter. If the operating current is too low, the motor torque will also be too low and operation will be unstable.

Measures for various cases

Phenomenon	Possible cause	Remedial action
The motor loses its synchronism while accelerating or operating.	The centers of the output shaft and the load shaft are not aligned.	Check the connection condition of the output shaft and the load shaft.
	A load is large or the load fluctuation is large.	<ul style="list-style-type: none"> • Check if large load fluctuations have occurred during operation. • Adjust the operating speed to the low-speed side of higher torque area. If the motor does not cause loss of synchronism at low-speed operation, reconsider the load condition.
	The starting speed is too high.	Set a lower starting speed so that the motor can be started stably.
	The acceleration rate is too short.	Set a longer acceleration rate so that the motor can be started stably.
Motor vibration is too large.	The load is small.	Lower the current with the "Base current" parameter. If the motor output torque is too large relative to the load, vibration will increase.
The motor position (travel amount) does not match the setting value.	The setting of resolution (step angle) is incorrect.	Check the "Base resolution setting" parameter and "Resolution" parameter.



When an alarm is being generated, check the alarm message via RS-485 communication or using the **MEXE02**.

8 Cables

This section describes cables shown in gray in the figure.

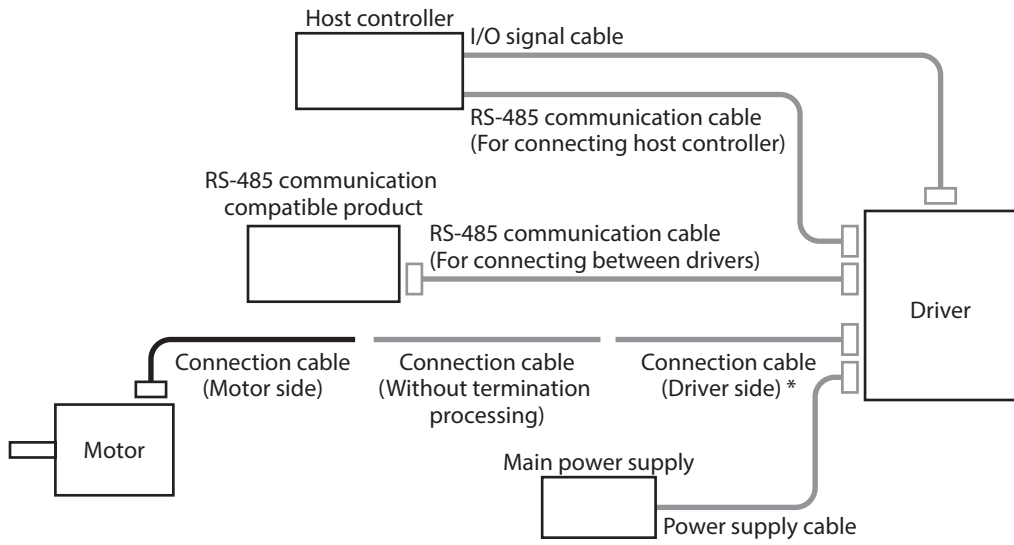

* It is a cable for 5-phase stepping motors and motorized actuators.



In addition to the cables described here, several types of connection cables are available, such as those that can directly connect between the motor and the driver. Check on the Oriental Motor Website for cables not described here.

8-1 Connection cables (Driver side)

These are cables for 5-phase stepping motors and motorized actuators. A connector is assembled at the driver side.

■ Connection cables

Model	Length [m (ft.)]
CC005N1	0.5 (1.6)
CC010N1	1 (3.3)

■ Flexible connection cables

Model	Length [m (ft.)]
CC005N1R	0.5 (1.6)
CC010N1R	1 (3.3)

8-2 Connection cables (Without termination processing)

These cables are used to extend the wiring distance between the motor and the driver.

■ Connection cables

Model	Length [m (ft.)]	Diameter of lead wires	Outer diameter [mm (in.)]
CC05PK5	5 (16.4)	AWG22 (0.3 m ²)	ø7.2 (ø0.283)
CC10PK5	10 (32.8)		

■ Flexible connection cables

These are cables for 5-phase stepping motors and motorized actuators. They cannot be used for 2-phase stepping motors.

Model	Length [m (ft.)]	Diameter of lead wires	Outer diameter [mm (in.)]
CC05PK5R	5 (16.4)	AWG22 (0.3 m ²)	ø5.8 (ø0.228)
CC10PK5R	10 (32.8)		

8-3 Power supply cable and I/O signal cable sets

These are a set of two cables, a power supply cable and an I/O signal cable.

A power supply cable is used to connect a driver and a main power supply, and an I/O signal cable is used to connect a driver and a host controller.

Model: **LHS003CC** [0.3 m (1 ft.)]

LHS010CC [1 m (3.3 ft.)]

8-4 RS-485 communication cables

There are two types of RS-485 communication cables, one for connecting between drivers and the other for connecting a host controller.

Connectors are assembled on both sides for a cable for connecting between drivers, and a connector is assembled on one side (driver side) for a cable for connecting a host controller.

Model: For connecting between drivers **LH0015-RWN** [0.15 m (0.5 ft.)]

For connecting a host controller **CC030-RS** [3 m (9.8 ft.)]



Note that the cable for connecting between drivers cannot be connected to a driver whose connector shape or pin assignment is different.

9 Accessories

9-1 Relay contact protection circuit/module

- **CR circuit for surge suppression**

This product is effective to suppress the surge which occurs in a relay contact part. Use it to protect the contacts of the relay or switch.

Model: **EPCR1201-2**

- **CR circuit module**

This product is effective to suppress the surge which occurs in a relay contact part. Use it to protect the contacts of the relay or switch.

Four pieces of CR circuit for surge suppression are mounted on the compact circuit, and this product can be installed to the DIN rail. This product can make the wiring easily and securely since it also supports terminal block connection.

Model: **VCS02**

10 Specifications

10-1 Product specifications

Input voltage		24 VDC±10 %
Input current		2-phase: 0.5 to 3.0 A * 5-phase: 0.6 to 3.0 A *
Interface	Control input	Number of input points: 7, photocoupler
	Control output	Number of output points: 2, photocoupler/open collector
	Field network	Modbus RTU (RS-485 communication)

* A current value varies depending on the product combined. Refer to p.18.

10-2 General specifications

Operating environment	Ambient temperature	0 to +50 °C (+32 to +122 °F) (non-freezing)
	Humidity	85 % or less (non-condensing)
	Altitude	Up to 1,000 m (3,300 ft.) above sea level
	Surrounding atmosphere	No corrosive gas, dust, water, or oil.
Storage environment Shipping environment	Ambient temperature	-25 to +70 °C (-13 to +158 °F) (non-freezing)
	Humidity	85 % or less (non-condensing)
	Altitude	Up to 3,000 m (10,000 ft.) above sea level
	Surrounding atmosphere	No corrosive gas, dust, water, or oil.

10-3 Communications specifications

Electrical characteristics	Compliant with EIA-485 Use a shielded twist pair cable and keep the total wiring distance up to 10 m (32.8 ft.).
Communication mode	Half-duplex communication Asynchronous mode (data: 8 bits, stop bit: 1 bit/2 bits, parity: none/even number/odd number)
Transmission speed	Selectable from 9,600 bps, 19,200 bps, 38,400 bps, 57,600 bps, 115,200 bps, 230,400 bps
Protocol	Modbus RTU mode
Number of connectable units	Up to 31 drivers can be connected to one host controller.

11 Regulations and standards

11-1 CE Marking / UKCA Marking

This product is affixed with the marks under the following directive/regulations.

- **EU EMC Directive / UK EMC Regulations**

Refer to "12-1 Compliance with EMC Directive/Regulations" on p.54 for details about conformity

- **EU RoHS Directive / UK RoHS Regulations**

This product does not contain the substances exceeding the restriction values.

11-2 Republic of Korea, Radio Waves Act

This product is affixed with the KC Mark under the Radio Waves Act, the Republic of Korea.

12 Noise elimination measures

There are two types of electrical noises: One is a noise to invade into the driver from the outside and cause the driver malfunction, and the other is a noise to emit from the driver and cause peripheral equipment malfunction.

For the noise that is invaded from the outside, take measures to prevent the driver malfunction. It is needed to take adequate measures because signal lines are very likely to be affected by the noise.

For the noise that is emitted from the driver, take measures to suppress it.

■ Measures against electrical noise

There are the following three methods mainly to take measures against the electrical noise.

● Noise suppression

- When relays or electromagnetic switches are used, use noise filters or CR circuits to suppress surge generated by them.
- Cover the driver by a metal plate such as aluminum. This is effective in shielding the electrical noise emitted from the driver.

● Prevention of noise propagation

- Separate the power lines such as the connection cables and power supply cables at least 100 mm (3.94 in.) from the signal lines such as an I/O signal cable and a RS-485 communication cable. In addition, do not bundle them or do not wire them in parallel. If the power lines and the signal lines have to cross, cross them at a right angle.
- For more effective elimination of noise, use shielded cables for power lines and signal lines or attach ferrite cores if non-shielded cables are used.
- Keep cables as short as possible without coiling and bundling extra lengths.
- Grounding multiple points will increase effect to block electrical noise because impedance on the grounding points is decreased. However, ground them so that a potential difference does not occur among the grounding points.
- To ground a shielded cable, use a metal cable clamp that can maintain contact with the entire circumference of the shielded cable, and ground as near the product as possible.

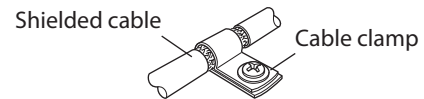

● Suppression of effect by noise propagation

- Loop the noise propagated cable around a ferrite core. Doing so will prevent the propagated noise invades into the driver or emits from the driver. The frequency band in which an effect by the ferrite core can be seen is generally 1 MHz or more. Check the frequency characteristics of the ferrite core used. When increasing the effect of noise attenuation by the ferrite core, loop the cable a lot.

■ Noise suppression product

● Noise filter

- Connect a noise filter (or equivalent) in the table on the AC input side of the DC power supply. When a power supply transformer is used, be sure to connect a noise filter on the AC input side of the power supply transformer. Doing so will prevent the propagated noise through the power line. Install the noise filter as close to the input terminals of DC power supply as possible.

Manufacturer	Model
SOSHIN ELECTRIC CO., LTD.	HF2010A-UPF
Schaffner EMC	FN2070-10-06

- Use the AWG18 (0.75 mm²) or thicker wire for the input and output cables of the noise filter, and secure firmly using a cable clamp or others so that the cable does not come off the enclosure.
- Place the input cable as far apart as possible from the output cable, and do not wire the cables in parallel. If the input and output cables are placed at a close distance or if they are wired in parallel, the noise in the enclosure affects the power cable through stray capacitance, and the noise suppressing effect will reduce.
- Connect the ground terminal of the noise filter to the grounding point, using as thick and short a wire as possible.
- When connecting a noise filter inside an enclosure, wire the input cable of the noise filter as short as possible. Wiring in long distance may reduce the noise suppressing effect.

■ **Our noise suppression product**

Check the model name on p.50.

● **Surge suppressor**

This product is effective to suppress the surge which occurs in a relay contact part. Connect it when using a relay or electromagnetic switch. CR circuit for surge suppression and CR circuit module are provided.

12-1 Compliance with EMC Directive/Regulations

Effective measures must be taken against the EMI that the motor and the driver may give to adjacent control-system equipment, as well as the EMS of the motor and the driver itself, in order to prevent a serious functional impediment in the machinery. Use of the following installation and wiring methods will enable the motor and driver to comply with the EMC Directive/Regulations.

Oriental Motor conducts EMC testing on its motors and drivers in accordance with "Example of installation and wiring" on p.55

The user is responsible for ensuring the machine's compliance with the EMC, based on the installation and wiring explained next.

⚠ CAUTION This equipment is not intended for use in residential environments nor for use on a low-voltage public network supplied in residential premises, and it may not provide adequate protection to radio reception interference in such environments.

● **Main power supply**

The driver is a product of DC power input. Use a DC power supply (switched-mode power supply, etc.) that complies with the EMC Directive/Regulations.

● **Connecting the signal cable**

Refer to "Prevention of noise propagation" on p.53.

● **Grounding method**

- The cable used to ground the motor and the driver must be as thick and short as possible so that no potential difference is generated.
- Choose a large, thick and uniformly conductive surface for the grounding point.
- Install the motor to a grounded metal plate.

● Example of installation and wiring

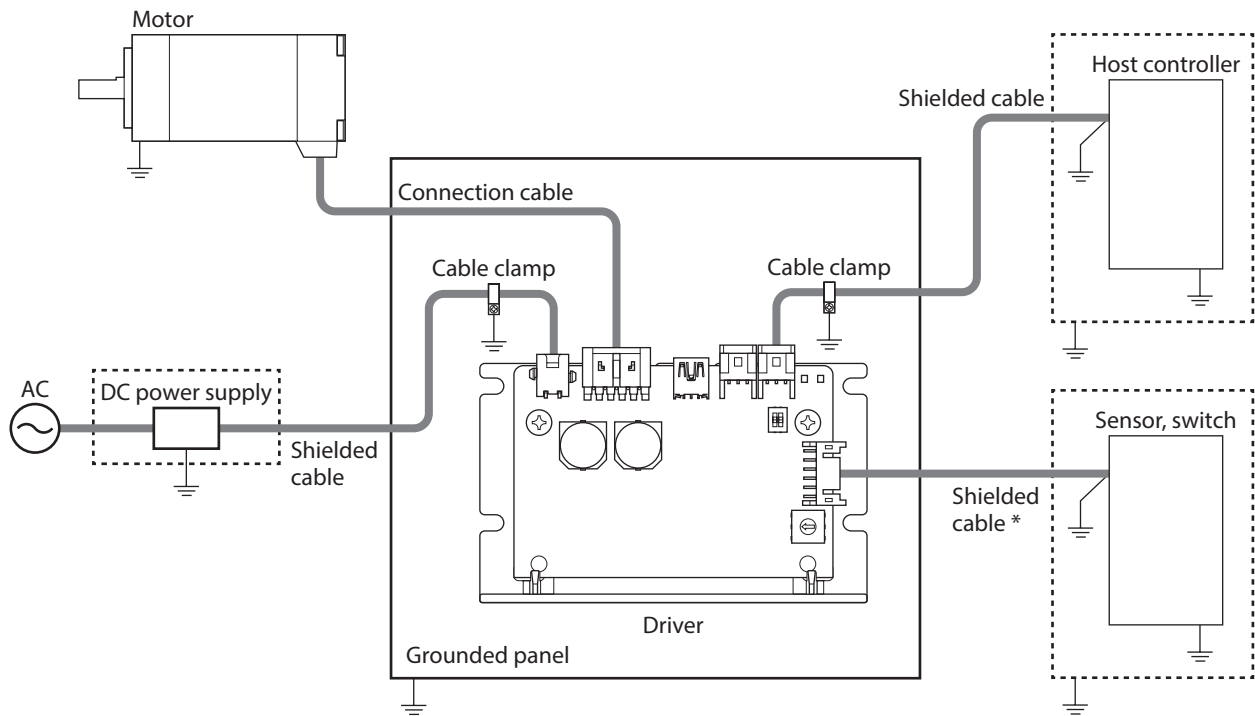

⏏ symbol indicate the grounding.

--- is a shielded box.

* Ground only the host side of the shielded cable.

Note The driver uses parts that are sensitive to electrostatic charge. Take measures against static electricity since static electricity may cause the driver to malfunction or suffer damage.

- Unauthorized reproduction or copying of all or part of this Manual is prohibited.
If a new copy is required to replace an original manual that has been damaged or lost, please contact your nearest Oriental Motor sales office.
- Oriental Motor shall not be liable whatsoever for any problems relating to industrial property rights arising from use of any information, circuit, equipment or device provided or referenced in this manual.
- Characteristics, specifications and dimensions are subject to change without notice.
- While we make every effort to offer accurate information in the manual, we welcome your input. Should you find unclear descriptions, errors or omissions, please contact your nearest Oriental Motor sales office.
- **Orientalmotor** is a registered trademark or trademark of Oriental Motor Co., Ltd., in Japan and other countries.
Modbus is a registered trademark of Schneider Automation Inc.
Other product names and company names mentioned in this manual may be registered trademarks or trademarks of their respective companies and are hereby acknowledged. The third-party products mentioned in this manual are recommended products, and references to their names shall not be construed as any form of performance guarantee. Oriental Motor is not liable whatsoever for the performance of these third-party products.

© Copyright ORIENTAL MOTOR CO., LTD. 2020

Published in December 2023

- Please contact your nearest Oriental Motor office for further information.

ORIENTAL MOTOR U.S.A. CORP.
Technical Support Tel:800-468-3982
8:30am EST to 5:00pm PST (M-F)

ORIENTAL MOTOR (EUROPA) GmbH
Schiessstraße 44, 40549 Düsseldorf, Germany
Technical Support Tel:00 800/22 55 66 22

ORIENTAL MOTOR (UK) LTD.
Unit 5 Faraday Office Park, Rankine Road,
Basingstoke, Hampshire RG24 8QB UK
Tel:+44-1256347090

ORIENTAL MOTOR (FRANCE) SARL
Tel:+33-1 47 86 97 50

ORIENTAL MOTOR ITALIA s.r.l.
Tel:+39-02-93906347

ORIENTAL MOTOR ASIA PACIFIC PTE. LTD.
Singapore
Tel:1800-842-0280

ORIENTAL MOTOR (MALAYSIA) SDN. BHD.
Tel:1800-806-161

ORIENTAL MOTOR (THAILAND) CO., LTD.
Tel:1800-888-881

ORIENTAL MOTOR (INDIA) PVT. LTD.
Tel:1800-120-1995 (For English)
1800-121-4149 (For Hindi)

TAIWAN ORIENTAL MOTOR CO., LTD.
Tel:0800-060708

SHANGHAI ORIENTAL MOTOR CO., LTD.
Tel:400-820-6516

INA ORIENTAL MOTOR CO., LTD.
Korea
Tel:080-777-2042

ORIENTAL MOTOR CO., LTD.
4-8-1 Higashiueno, Taito-ku, Tokyo
110-8536 Japan
Tel:+81-3-6744-0361
www.orientalmotor.co.jp/ja