



5-Phase Stepping Motor and Driver package

CRK Series

OPERATING MANUAL



Table of contents

1	Introduction	2	7	Setting	38
2	Safety precautions	4	8	Inspection	45
3	Precautions for use.....	6	9	Troubleshooting and remedial actions	46
4	Preparation	8	10	Accessories (sold separately) ...	49
5	Installation	15			
6	Connection	24			

Thank you for purchasing an Oriental Motor product.
This Manual describes product handling procedures and safety precautions.

- Please read it thoroughly to ensure safe operation.
- Always keep the manual where it is readily available.

1 Introduction

■ Before using the product

The product described in this manual has been designed and manufactured for use in general industrial machinery, and must not be used for any other purpose. For the driver's power supply, use a DC power supply with reinforced insulation on its primary and secondary sides. Oriental Motor Co., Ltd. is not responsible for any damage caused through failure to observe this warning.

■ Overview of the product

The **CRK** series is a motor and driver package product comprised of an open-case microstep driver equipped with smooth drive function and a five-phase stepping motor or various geared motors designed for high torque and low vibration. The smooth drive function allows microstep drive to be performed automatically within the driver without having to change the pulse setting, thereby enabling low vibration, low noise operation.

■ Standards and CE Marking

This product is recognized by UL and bears the CE Marking (EMC Directive) in compliance with the EN Standards.

● Applicable Standards

Motor

Motor type [unit: mm (in.)]	Applicable Standards *6	Certification Body	Standard File No.	CE Marking
High-resolution type	UL 60950-1	UL	E208200	EMC Directive *7
High-torque type	CSA C22.2 No.60950-1			
Standard type	UL 60950-1 CSA C22.2 No.60950-1	UL	E208200	
□20 (0.79) *1				
∅22 (0.87) *2				
□28 (1.10) *3				
PL geared type	UL 1004-1, UL 2111	UL	E64199	
□30 (1.18) *1				
PS geared type	UL 1004-1, UL 2111 CSA C22.2 No.77 CSA C22.2 No.100	UL	E64199	
□60 (2.36) *4				
PN geared type	UL 1004-1, UL 2111 CSA C22.2 No.77 CSA C22.2 No.100	UL	E64199	
□42 (1.65)				
Harmonic geared type	UL 1004-1, UL 2111 CSA C22.2 No.77 CSA C22.2 No.100	UL	E64199	
□60 (2.36) *5				

*1 Harmonic geared type only.

*2 **PS** geared type only.

*3 **TH** geared type, **PS** geared type and **PN** geared type only.

*4 **CRK566H**□**PB** only.

*5 Excluding **CRK566H**□**PB**.

*6 Approval conditions for UL 60950, UL 60950-1: Class III equipment, SELV circuit, Pollution degree 2.

*7 Oriental Motor declares compliance with the EMC Directives based on motor and driver combinations.

Driver

Applicable Standards *1	Certification Body	Standard File No.	CE Marking
UL 60950-1 *2 CSA C22.2 No.60950-1 *2	UL	E208200	EMC Directive *3

*1 Approval conditions for UL 60950, UL 60950-1: Class III equipment, SELV circuit, Pollution degree 2

*2 Excluding CRD5128PB.

*3 Oriental Motor declares compliance with the EMC Directives based on motor and driver combinations.

● Low Voltage Directive

This product is not subject to the EC's Low Voltage Directive because its input power supply voltage is 24 VDC. However, the user is advised to perform the following actions when conducting product installation and connection.

- This product is designed for use within machinery, so it should be installed within an enclosure.
- For the driver's power supply, use a DC power supply with reinforced insulation on its primary and secondary sides.

● EMC Directive

This product has conducted EMC testing under the conditions specified in "Example of installation and wiring" on p.36.

The compliance with the EMC Directive of the entire equipment will vary depending on such factors as the configuration, wiring and installation condition of other control-system devices or electrical parts used together with this product.

Therefore, be sure to confirm the compliance of the equipment in a finished condition that all parts including this product are installed in the equipment.

Applicable Standards



EMI	EN 61000-6-4, EN 55011
EMS	EN 61000-6-2

■ Hazardous substances

The products do not contain the substances exceeding the restriction values of RoHS Directive (2011/65/EU).

2 Safety precautions

The precautions described below are intended to prevent danger or injury to the user and other personnel through safe, correct use of the product. Use the product only after carefully reading and fully understanding these instructions.

 WARNING	Handling the product without observing the instructions that accompany a “Warning” symbol may result in serious injury or death.
 CAUTION	Handling the product without observing the instructions that accompany a “Caution” symbol may result in injury or property damage.
 Note	The items under this heading contain important handling instructions that the user should observe to ensure safe use of the product.

WARNING

General

- Do not use the product in explosive or corrosive environments, in the presence of flammable gases, locations subjected to splashing water, or near combustibles. Doing so may result in fire or injury.
- Assign qualified personnel the task of installing, wiring, operating/controlling, inspecting and troubleshooting the product. Failure to do so may result in fire or injury.
- If this product is used in an elevator application, be sure to provide a measure for the position retention of moving parts. The motor loses its holding torque when the power supply is turned off. Failure to provide such a measure may cause the moving parts to fall, resulting in injury or damage to the equipment.

Installation

- Install the motor and driver in their enclosures in order to prevent injury.

Connection

- Keep the driver's power supply input voltage within the specified range to avoid fire.
- For the driver's power supply, use a DC power supply with reinforced insulation on its primary and secondary sides. Failure to do so may result in electric shock.
- Connect the cables securely according to the wiring diagram in order to prevent fire.
- Do not forcibly bend, pull or pinch the power supply cable or motor cable. Doing so may result in fire.

Operation

- Turn off the driver power supply in the event of a power failure, or the motor may suddenly start when the power is restored and may cause injury or damage to equipment.
- Do not turn the A.W.OFF input to ON while the motor is operating. The motor will stop and lose its holding ability, which may result in injury or damage to the equipment.

Repair, disassembly and modification

- Do not disassemble or modify the motor or driver. This may cause injury. Refer all such internal inspections and repairs to the branch or sales office from which you purchased the product.

CAUTION

General

- Do not use the motor and driver beyond their specifications. Doing so may result in injury or damage to equipment.
- Keep your fingers and objects out of the openings in the motor and driver. Failure to do so may result in fire or injury.
- Do not touch the motor or driver during operation or immediately after stopping. The surfaces are hot and may cause a skin burn(s).
- If the power supply cable or motor cable connected the driver are forcibly bent or pulled, the driver will receive stress and may suffer damage.

Transportation

- Do not hold the motor output shaft or motor cable. This may cause injury.

Installation

- Keep the area around the motor and driver free of combustible materials in order to prevent fire or a skin burn(s).
- To prevent the risk of damage to equipment, leave nothing around the motor and driver that would obstruct ventilation.
- Provide a cover over the rotating parts (output shaft) of the motor to prevent injury.

Operation

- Use a motor and driver only in the specified combination. An incorrect combination may cause a fire.
- Provide an emergency stop device or emergency stop circuit external to the equipment so that the entire equipment will operate safely in the event of a system failure or malfunction. Failure to do so may result in injury.
- Before supplying power to the driver, turn all input signals to the driver to OFF. Otherwise, the motor may start suddenly and cause injury or damage to equipment.
- Do not touch the rotating parts (output shaft) of the motor during operation. This may cause injury.
- Before moving the motor output shaft directly with the hands (as in the case of manual positioning), confirm that the driver A.W.OFF input is ON to prevent injury.
- Immediately when trouble has occurred, stop running and turn off the driver power supply. Failure to do so may result in fire or injury.

Disposal

- To dispose of the motor and driver, disassemble it into parts and components as much as possible and dispose of individual parts/components as industrial waste.

3 Precautions for use

This section covers limitations and requirements the user should consider when using the **CRK** series.

- **Conduct the insulation resistance measurement or withstand voltage test separately on the motor and the driver.**

Conducting the insulation resistance measurement or withstand voltage test with the motor and driver connected may result in injury or damage to equipment.

- **Do not apply a radial load and axial load in excess of the specified permissible limit.**

Be sure to operate the motor within the specified permissible limit of radial load and axial load. Operating it under an excessive radial load and axial load may damage the motor bearings (ball bearings). See p.18 for details.

- **Motor case temperature**

The motor casing's surface temperature may exceed 100 °C (212 °F) under certain conditions (ambient temperature, operating speed, duty cycle, etc.). Keeping the surface temperature of the motor casing below 100 °C (212 °F) will also maximize the life of the motor bearings (ball bearings).

Use the geared type motor in a condition where the gear case temperature does not exceed 70 °C (158 °F), in order to prevent deterioration of grease and parts in the gear case.

- **Holding torque at standstill**

The holding torque is reduced by the current cutback function of the driver at motor standstill. When selecting a motor, check the holding torque at motor standstill in the specifications on the catalog.

- **Noise measures**

Refer to p.34 for the noise measures.

- **Maximum torque of geared type motor**

Always operate geared types with loads not exceeding their maximum torque. If a geared type is operated with a load exceeding the maximum torque, the gear will be damaged.

- **Rotating direction of the gear output shaft**

The relationship between the rotating direction of the motor shaft and that of the gear output shaft changes as follows, depending on the gear type and gear ratio.

Gear type	Gear ratio	Rotating direction (Relative to the motor rotation direction)			
		Motor size [mm (in.)]			
		20 (0.79) ø22 (0.87)	28 (1.10) 30 (1.18)	42 (1.65)	60 (2.36)
TH gear	3.6 7.2 10	–	Opposite direction	Same direction	
	20 30	–	Same direction	Opposite direction	
PL gear PS gear PN gear	All gear ratio	Same direction			
Harmonic gear		Opposite direction			

- **Grease of geared motor**

On rare occasions, a small amount of grease may ooze out from the geared motor.

If there is concern over possible environmental damage resulting from the leakage of grease, check for grease stains during regular inspections. Alternatively, install an oil pan or other device to prevent leakage from causing further damage. Oil leakage may lead to problems in the customer's equipment or products.

- **Regeneration**

When a large inertial load is operated at high speed, regenerative energy will generate and increase the power supply voltage, which can damage the driver. Review the operating condition and make sure regenerative voltage will not generate.

4 Preparation

This section covers the points to be checked along with the names and functions of the respective parts.

4-1 Checking the product

Verify that the items listed below are included.

Report any missing or damaged items to the branch or sales office from which you purchased the product. See "4-2 Combinations of motors and drivers" on p.9 for the motor and driver combinations.

- Motor 1 unit
- Driver 1 unit
- Connector leads 0.6 m (2 ft.) 1 pc.
(Connector leads are supplied only with the connector coupled type motor and driver package products.)
- Operating manual (this manual)..... 1 copy
- Connector housing/contact 1 set (packed in a bag)

Manufacturer: Molex Incorporated

Model	Connector	Housing	Contact
CRD5103PB CRD5107PB CRD5107HPB CRD5114PB CRD5103P CRD5107P CRD5107HP CRD5114P	For power supply	1 pc. 51103-0200 (2 poles)	19 pcs. 50351-8100
	For I/O signals	1 pc. 51103-1200 (12 poles)	
	For motor	1 pc. 51103-0500 (5 poles)	
CRD5128PB	For power supply	1 pc. 51067-0200 (2 poles)	2 pcs. 50217-9101
	For I/O signals	1 pc. 51103-1200 (12 poles)	12 pcs. 50351-8100
	For motor	1 pc. 51067-0500 (5 poles)	5 pcs. 50217-9101



When removing the driver from the conductive protection bag, make sure your hands are not charged with static electricity. This is to prevent damage to the driver due to static electricity.

4-2 Combinations of motors and drivers

- □ indicates **A** (single shaft) or **B** (double shaft).
- ■ represents a number indicating the gear ratio.

■ High-resolution type

Model	Motor model	Driver model
CRK523PM□P	PK523PM□	CRD5103P
CRK523PM□PB		CRD5103PB
CRK523HPM□P	PK523HPM□	CRD5107HP
CRK523HPM□PB		CRD5107HPB
CRK524PM□P	PK524PM□	CRD5103P
CRK524PM□PB		CRD5103PB
CRK524HPM□P	PK524HPM□	CRD5107HP
CRK524HPM□PB		CRD5107HPB
CRK525PM□P	PK525PM□	CRD5103P
CRK525PM□PB		CRD5103PB
CRK525HPM□P	PK525HPM□	CRD5107HP
CRK525HPM□PB		CRD5107HPB
CRK544PM□P	PK544PM□	CRD5107P
CRK544PM□PB		CRD5107PB
CRK546PM□P	PK546PM□	CRD5107P
CRK546PM□PB		CRD5107PB
CRK564PM□P	PK564PM□	CRD5114P
CRK564PM□PB		CRD5114PB
CRK566PM□P	PK566PM□	CRD5114P
CRK566PM□PB		CRD5114PB
CRK569PM□P	PK569PM□	CRD5114P
CRK569PM□PB		CRD5114PB

■ High-torque type

Model	Motor model	Driver model
CRK513P□P	PK513P□	CRD5103P
CRK513P□PB		CRD5103PB
CRK523P□P	PK523P□	CRD5103P
CRK523P□PB		CRD5103PB
CRK523HP□P	PK523HP□	CRD5107HP
CRK523HP□PB		CRD5107HPB
CRK525P□P	PK525P□	CRD5103P
CRK525P□PB		CRD5103PB
CRK525HP□P	PK525HP□	CRD5107HP
CRK525HP□PB		CRD5107HPB
CRK544P□P	PK544P□	CRD5107P
CRK544P□PB		CRD5107PB
CRK546P□P	PK546P□	CRD5107P
CRK546P□PB		CRD5107PB

■ Standard type

Model	Motor model	Driver model
CRK543□P	PK543N□W	CRD5107P
CRK543□PB		CRD5107PB
CRK544□P	PK544N□W	CRD5107P
CRK544□PB		CRD5107PB
CRK545□P	PK545N□W	CRD5107P
CRK545□PB		CRD5107PB
CRK564□P	PK564N□W	CRD5114P
CRK564□PB		CRD5114PB
CRK566□P	PK566N□W	CRD5114P
CRK566□PB		CRD5114PB
CRK566H□PB	PK566HN□W	CRD5128PB
CRK569□P	PK569N□W	CRD5114P
CRK569□PB		CRD5114PB
CRK569H□PB	PK569HN□W	CRD5128PB

■ TH geared type

Model	Motor model	Driver model
CRK523P□P-T■	PK523P□-T■	CRD5103P
CRK523P□PB-T■		CRD5103PB
CRK543□P-T■	PK543□W-T■	CRD5107P
CRK543□PB-T■		CRD5107PB
CRK564□P-T■	PK564□W-T■	CRD5114P
CRK564□PB-T■		CRD5114PB

■ PL geared type

Model	Motor model	Driver model
CRK543□P-P■	PK543□W-P■	CRD5107P
CRK543□PB-P■		CRD5107PB
CRK545□P-P■	PK545□W-P■	CRD5107P
CRK545□PB-P■		CRD5107PB
CRK564□P-P■	PK564□W-P■	CRD5114P
CRK564□PB-P■		CRD5114PB
CRK566□P-P■	PK566□W-P■	CRD5114P
CRK566□PB-P■		CRD5114PB

■ PS geared type

Model	Motor model	Driver model
CRK513P□P-PS■	PK513P□-PS■	CRD5103P
CRK513P□PB-PS■		CRD5103PB
CRK523P□P-PS■	PK523P□-PS■	CRD5103P
CRK523P□PB-PS■		CRD5103PB
CRK543□P-PS■	PK543□W-PS■	CRD5107P
CRK543□PB-PS■		CRD5107PB
CRK545□P-PS■	PK545□W-PS■	CRD5107P
CRK545□PB-PS■		CRD5107PB
CRK564□P-PS■	PK564□W-PS■	CRD5114P
CRK564□PB-PS■		CRD5114PB
CRK566□P-PS■	PK566□W-PS■	CRD5114P
CRK566□PB-PS■		CRD5114PB

■ PN geared type

Model	Motor model	Driver model
CRK523P□P-N■	PK523P□-N■	CRD5103P
CRK523P□PB-N■		CRD5103PB
CRK544□P-N■	PK544□W-N■	CRD5107P
CRK544□PB-N■		CRD5107PB
CRK564□P-N■	PK564□W-N■	CRD5114P
CRK564□PB-N■		CRD5114PB
CRK566□P-N■	PK566□W-N■	CRD5114P
CRK566□PB-N■		CRD5114PB

■ Harmonic geared type

Model	Motor model	Driver model
CRK513P□P-H■	PK513P□-H■S	CRD5103P
CRK513P□PB-H■		CRD5103PB
CRK523P□P-H■	PK523HP□-H■S	CRD5107HP
CRK523P□PB-H■		CRD5107HPB
CRK543□P-H■	PK543□W-H■S	CRD5107P
CRK543□PB-H■		CRD5107PB
CRK564□P-H■	PK564□W-H■S	CRD5114P
CRK564□PB-H■		CRD5114PB

4-3 Names and functions of parts

This section covers the names and functions of parts in the motor and driver.
See the reference page indicated for details on each part.

■ Motor

Illustration shows the PK56□ type.

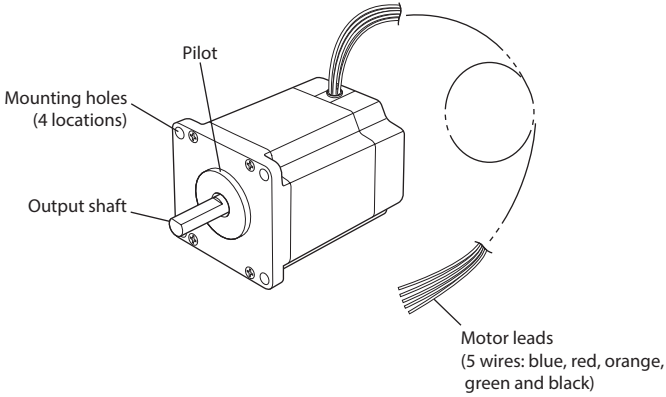

■ Driver

- CRD5103PB, CRD5107PB, CRD5107HPB, CRD5114PB

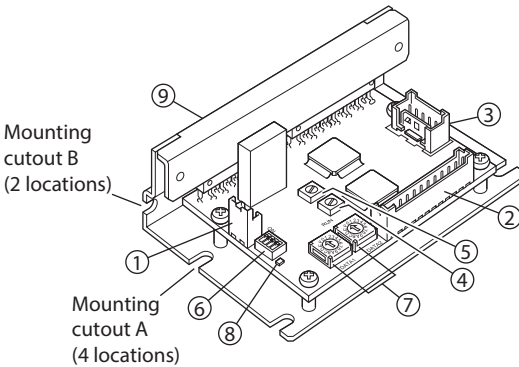

- CRD5103P, CRD5107P, CRD5107HP, CRD5114P

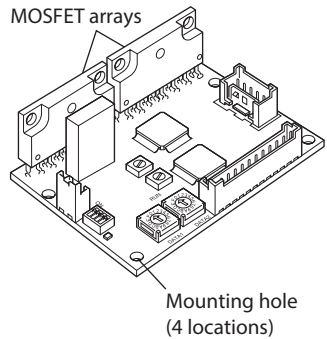

● CRD5128PB

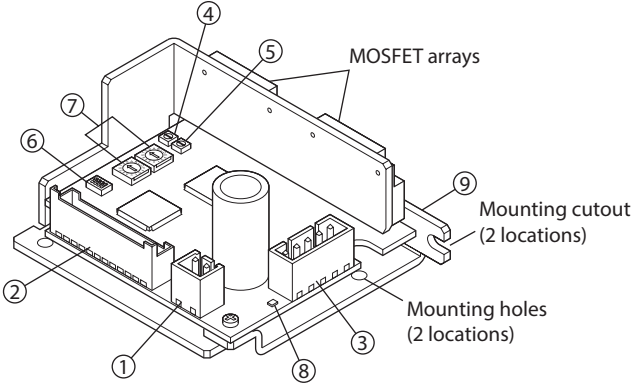

No.	Name	Description
1	Power supply connector (CN1) [p.26]	Connect to a 24 VDC power supply.
2	I/O signals connector (CN2) [p.26]	Connect to I/O signals.
3	Motor connector (CN3) [p.26]	Connect to motor leads.
4	Motor operating current potentiometer (RUN) [p.41]	Set the operating current of the motor. If there is sufficient torque, the current setting can be reduced to suppress increases in motor/driver temperatures. The potentiometer is factory set to [the rated current].
5	Motor standstill current potentiometer (STOP) [p.43]	Set the current when the motor is at a standstill (in the current cutback state)The potentiometer is factory set to [50% of the rated current].
6	Function select switches (1P/2P, OFF/SD, R2/R1) [p.38 to p.40]	<ul style="list-style-type: none"> • Pulse input mode select switch (1P/2P): Switch the pulse input mode between 1-pulse input mode and 2-pulse input mode. • Smooth drive function select switch (OFF/SD): Set or cancel the smooth drive function. • Resolution select switch (R2/R1): Switch the reference step angle between R1 and R2.
7	Step angle setting switch (DATA1, DATA2) [p.38]	You can set a desired step angle by selecting it from among the 16 step angles.
8	Power supply input indicator (LED)	This LED remains lit while the power supply is input.
9	Mounting plate [p.21]	—

5 Installation

This chapter explains the installation location and installation methods of the motor and driver, as well as how to install a load.

5-1 Location for installation

The motor and driver are designed and manufactured for installation in equipment. Install them in a well-ventilated location that provides easy access for inspection.

The location must also satisfy the following conditions:

- Inside an enclosure that is installed indoors (provide vent holes)
- Operating ambient temperature

Motor: -10 to $+50$ °C ($+14$ to $+122$ °F) (non-freezing)

PS geared type of $\varnothing 22$ mm ($\varnothing 0.87$ in.): 0 to $+50$ °C ($+32$ to $+122$ °F) (non-freezing)

Harmonic geared type: 0 to $+40$ °C ($+32$ to $+104$ °F) (non-freezing)

Driver: 0 to $+40$ °C ($+32$ to $+104$ °F) (non-freezing)

- Operating ambient humidity 85% or less (non-condensing)
- Area that is free of explosive atmosphere or toxic gas (such as sulfuric gas) or liquid
- Area not exposed to direct sun
- Area free of excessive amount of dust, iron particles or the like
- Area not subject to splashing water (rain, water droplets), oil (oil droplets) or other liquids
- Area free of excessive salt
- Area not subject to continuous vibration or excessive shocks
- Area free of excessive electromagnetic noise (from welders, power machinery, etc.)
- Area free of radioactive materials, magnetic fields or vacuum

5-2 Installing the motor

■ Installation direction

The motor can be installed in any direction.

■ Installation method

Install the motor onto an appropriate flat metal plate having excellent vibration resistance and heat conductivity.

When installing the motor, secure it with four bolts (not supplied) through the four mounting holes provided. Do not leave a gap between the motor and metal plate.

Note

- Insert the pilot located on the motor's installation surface into the mounting plate's.
 - When installing the motor, do not apply strong force using a hammer or other tools. Doing so may cause damage to the motor.
-

Installation method A

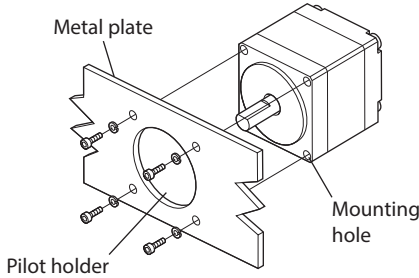

Installation method B

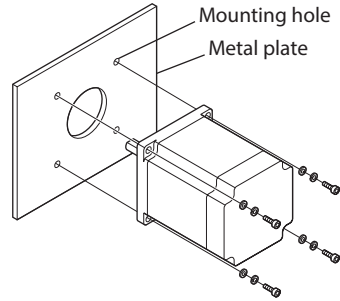

Bolt size, tightening torque and installation method

Motor type	Frame size [mm (in.)]	Bolt size	Tightening torque [N·m (oz-in)]	Effective depth of bolt [mm (in.)]	Installation method
High-resolution type High-torque type Standard type	20 (0.79)	M2	0.25 (35)	2.5 (0.098)	A
	28 (1.10)	M2.5	0.5 (71)	2.5 (0.098)	
	42 (1.65)	M3	1 (142)	4.5 (0.177)	
	60 (2.36)	M4	2 (280)	–	B
TH geared type	28 (1.10)	M2.5	0.5 (71)	4 (0.157)	A
	42 (1.65)	M4	2 (280)	8 (0.315)	
	60 (2.36)				
PL geared type	20 (0.79) *1	M2	0.25 (35)	5 (0.197) *3	
PS geared type	28 (1.10) *2	M3	1 (142)	6 (0.236)	
PN geared type	42 (1.65)	M4	2 (280)	8 (0.315)	
Harmonic geared type	60 (2.36)	M5	2.5 (350)	10 (0.394)	

*1 \varnothing 22 mm (0.87 in.) for the PS geared type

*2 30 mm (1.18 in.) for the Harmonic geared type

*3 3.5 mm (0.138 in.) for the PS geared type

5-3 Installing a load

When connecting a load to the motor, align the centers of the motor's output shaft and load shaft. Also, keep the radial load and axial load to the permissible values or below.



- When coupling the load to the motor, pay attention to the centering of the shafts, belt tension, parallelism of the pulleys, and so on. Securely tighten the coupling and pulley set screws.
- Be careful not to damage the output shaft or bearings when installing a coupling, pulley or parallel key to the motor's output shaft.
- Do not modify or machine the motor's output shaft. Doing so may damage the bearings and destroy the motor.

- **Using a coupling**

Align the centers of the motor's output shaft and load shaft in a straight line.

- **Using a belt drive**

Align the motor's output shaft and load shaft in parallel with each other, and position both pulleys so that the line connecting their centers is at a right angle to the shafts.

- **Using a gear drive**

Align the motor's output shaft and gear shaft in parallel with each other, and let the gears mesh at the center of the tooth widths.

- **Connecting with a key (Geared motor)**

With a geared motor, to connect a load to the gear output shaft having a key groove, first provide a key groove on the load and fix the load with the gear output shaft using the supplied key.

- **Installing on the flange surface (Harmonic geared type)**

With a harmonic geared type, a load can be installed directly to the gear using the load mounting holes provided on the flange surface.

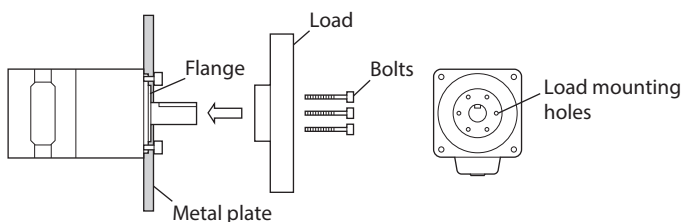

Model	Bolt size	Number of bolts	Tightening torque [N·m (oz-in)]	Effective depth of thread [mm (in.)]
CRK513	M2	3	0.35 (49)	3 (0.118)
CRK523	M3	4	1.4 (198)	4 (0.157)
CRK543	M3	6	1.4 (198)	5 (0.197)
CRK564	M4	6	2.5 (350)	6 (0.236)

Note

- When installing a load on the flange surface, the load cannot be affixed using the key groove (or flat surface) in the output shaft.
- Design an appropriate installation layout so that the load will not contact the metal plate or bolts used for installing the motor.

5-4 Permissible radial load and permissible axial load

The radial load and the axial load on the motor's output shaft must be kept under the permissible values listed on below.

The figures in parenthesis { } are the values for the High-resolution or High-torque type motors.

Motor type	Model	Gear ratio	Permissible radial load [N (lb.)]					Permissible axial load [N (lb.)]	
			Distance from the tip of motor's output shaft [mm (in.)]						
			0 (0)	5 (0.20)	10 (0.39)	15 (0.59)	20 (0.79)		
High-resolution High-torque Standard	CRK513	-	12 (2.7)	15 (3.3)	-	-	-	3 (0.67)	
	CRK523		25 (5.6)	34 (7.6)	52 (11.7)	-	-	5 (1.12)	
	CRK524								
	CRK525								
	CRK543		-	20 (4.5)	25 (5.6)	34 (7.6)	52 (11.7)	-	10 (2.2)
	CRK544								
	CRK545								
	CRK546								
	CRK564		63 (14.1) {90 (20)}	75 (16.8) {100 (22)}	95 (21) {130 (29)}	130 (29) {180 (40)}	190 (42) {270 (60)}	20 (4.5) {20 (4.5)}	
	CRK566								
CRK569									
TH geared	CRK523	3.6, 7.2, 10, 20, 30	15 (3.3)	17 (3.8)	20 (4.5)	23 (5.1)	-	10 (2.2)	
	CRK543		10 (2.2)	14 (3.1)	20 (4.5)	30 (6.7)	-	15 (3.3)	
	CRK564		70 (15.7)	80 (18)	100 (22)	120 (27)	150 (33)	40 (9)	
PL geared	CRK513	4, 16	20 (4.5)	30 (6.7)	-	-	-	20 (4.5)	
	CRK523	5, 7.2, 10	45 (10.1)	60 (13.5)	80 (18)	100 (22)	-	20 (4.5)	
	CRK545	5, 7.2, 10	73 (16.4)	84 (18.9)	100 (22)	123 (27)	-	50 (11.2)	
	CRK543	25, 36, 50	109 (24)	127 (28)	150 (33)	184 (41)	-		

Motor type	Model	Gear ratio	Permissible radial load [N (lb.)]					Permissible axial load [N (lb.)]
			Distance from the tip of motor's output shaft [mm (in.)]					
			0 (0)	5 (0.20)	10 (0.39)	15 (0.59)	20 (0.79)	
PL geared	CRK566	5	200 (45)	220 (49)	250 (56)	280 (63)	320 (72)	100 (22)
		7.2, 10	250 (56)	270 (60)	300 (67)	340 (76)	390 (87)	
	CRK564	25, 36, 50	330 (74)	360 (81)	400 (90)	450 (101)	520 (117)	
PS geared	CRK513	4, 16	20 (4.5)	30 (6.7)	–	–	–	20 (4.5)
	CRK523	5, 7.2, 10	45 (10.1)	60 (13.5)	80 (18)	100 (22)	–	40 (9)
	CRK545	5	70 (15.7)	80 (18)	95 (21)	120 (27)	–	100 (22)
		7.2	80 (18)	90 (20)	110 (24)	140 (31)	–	
		10	85 (19.1)	100 (22)	120 (27)	150 (33)	–	
	CRK543	25	120 (27)	140 (31)	170 (38)	210 (47)	–	100 (22)
		36	130 (29)	160 (36)	190 (42)	240 (54)	–	
		50	150 (33)	170 (38)	210 (47)	260 (58)	–	
	CRK566	5	170 (38)	200 (45)	230 (51)	270 (60)	320 (72)	200 (45)
		7.2	200 (45)	220 (49)	260 (58)	310 (69)	370 (83)	
		10	220 (49)	250 (56)	290 (65)	350 (78)	410 (92)	
PS geared	CRK564	25	300 (67)	340 (76)	400 (90)	470 (105)	560 (126)	200 (45)
		36	340 (76)	380 (85)	450 (101)	530 (119)	630 (141)	
		50	380 (85)	430 (96)	500 (112)	600 (135)	700 (157)	

Motor type	Model	Gear ratio	Permissible radial load [N (lb.)]					Permissible axial load [N (lb.)]		
			Distance from the tip of motor's output shaft [mm (in.)]							
			0 (0)	5 (0.20)	10 (0.39)	15 (0.59)	20 (0.79)			
PN geared	CRK523	5, 7.2, 10	45 (10.1)	60 (13.5)	80 (18)	100 (22)	–	40 (9)		
	CRK544	5	80 (18)	95 (21)	120 (27)	160 (36)	–	100 (22)		
		7.2	90 (20)	110 (24)	130 (29)	180 (40)	–			
		10	100 (22)	120 (27)	150 (33)	200 (45)	–			
	CRK566	5	240 (54)	260 (58)	280 (63)	300 (67)	330 (74)	200 (45)		
		7.2	270 (60)	290 (65)	310 (69)	340 (76)	370 (83)			
		10	300 (67)	320 (72)	350 (78)	380 (85)	410 (92)			
	CRK564	25	410 (92)	440 (99)	470 (105)	520 (117)	560 (126)			
		36	360 (81)	410 (92)	480 (108)	570 (128)	640 (144)			
		50	360 (81)	410 (92)	480 (108)	570 (128)	700 (157)			
	Harmonic geared	CRK513	50,100	50 (11.2)	75 (16.8)	–	–		–	60 (13.5)
		CRK523		110 (24)	135 (30)	175 (39)	250 (56)		–	140 (31)
CRK543		180 (40)		220 (49)	270 (60)	360 (81)	510 (114)		220 (49)	
CRK564		320 (72)		370 (83)	440 (99)	550 (123)	720 (162)	450 (101)		

Note

- Failure due to fatigue may occur if the motor's bearings and output shaft are subject to repeated loading by an radial or axial load that is in excess of the permissible limit.
- The permissible radial load and permissible axial load of the **PS** geared type and **PN** geared type represent the value that the service life of the gear part satisfies 20,000 hours when either of the radial load or axial load is applied to the gear output shaft.

■ Permissible moment load of the harmonic geared type

When installing an arm or table on the flange surface, calculate the moment load using the formula below if the flange surface receives any eccentric load.

The moment load should not exceed the permissible value specified in the table.

Moment load: M [N·m (oz-in)] = $F \times L$

Model	Permissible moment load [N·m (oz-in)]
CRK513	0.7 (99)
CRK523	2.9 (410)
CRK543	5.6 (790)
CRK564	11.6 (1640)

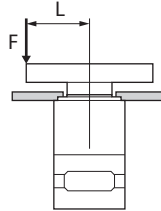

5-5 Installing the driver

When installing the driver in the device, mount it vertically or horizontally. Installing the driver under conditions other than this could reduce its radiation effect. Fix the driver directly to the metal enclosure using screws.

The items shown below are necessary in order to mount the driver. (The items are not included and must be provided by the customer.)

Torque the mounting screw to 0.5 N·m (71 oz-in).

Driver model	CRD5103PB CRD5107PB CRD5107HPB CRD5114PB	CRD5103P CRD5107P CRD5107HP CRD5114P	CRD5128PB
M3 screws	4 pcs. (2 pcs.) *	4 pcs.	2 pcs.
M3 spring washers	4 pcs. (2 pcs.) *	4 pcs.	2 pcs.
M3 nuts (Not necessary if screw holes are provided in the enclosure.)	4 pcs. (2 pcs.) *	4 pcs.	2 pcs.
Spacers [5 mm (0.20 in.) or more]	—	4 pcs.	—

* The figures in () apply when the mounting cutout B is used.

There must be a clearance of at least 25 mm (0.98 in.) and 50 mm (1.97 in.) in the horizontal and vertical directions, respectively, between the driver and enclosure or other equipment. When two or more drivers are to be installed side by side, provide 20 mm (0.79 in.) and 50 mm (1.97 in.) clearances in the horizontal and vertical directions, respectively.

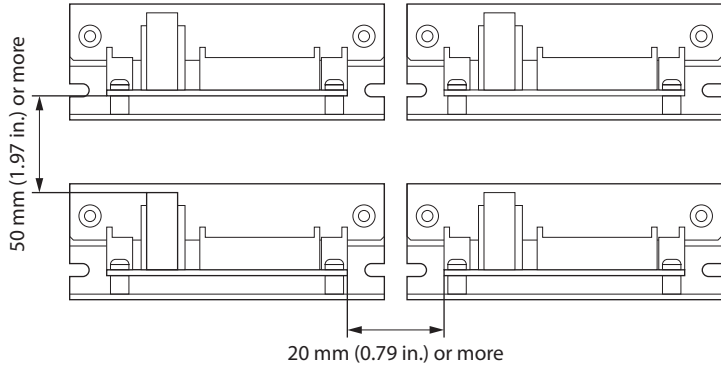

Note

- Install the driver in an enclosure.
- Do not install any equipment that generates a large amount of heat near the driver.
- Check ventilation if the ambient temperature of the driver exceeds 40 °C (104 °F).

- CRD5103PB, CRD5107PB, CRD5107HPB, CRD5114PB, CRD5128PB

Illustration shows CRD5103PB.

Horizontal installation

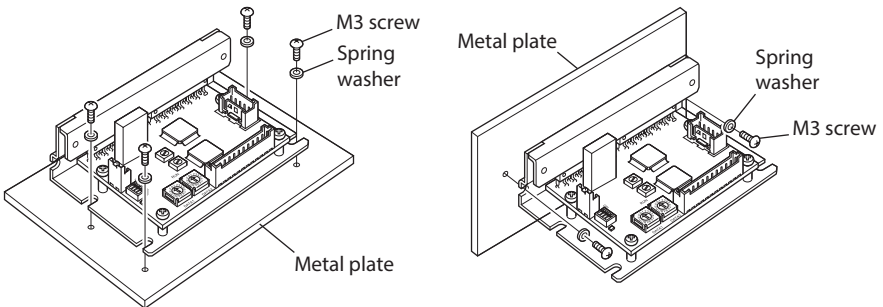

* For CRD5128, affix with screws (two locations).

Vertical installation

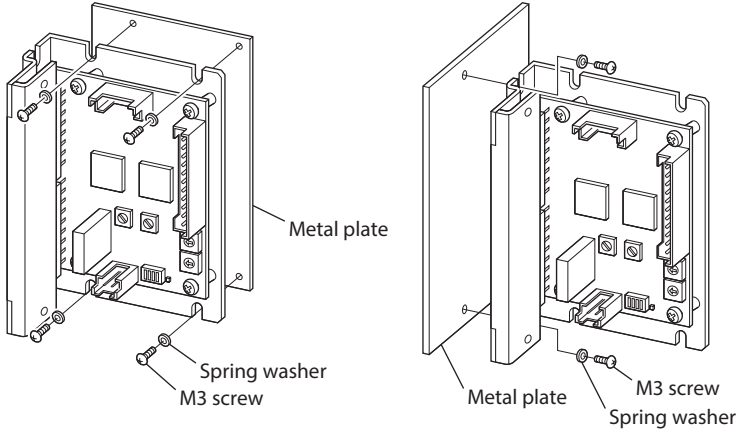

* For CRD5128, affix with screws (two locations).

Note

- Review the operating conditions if the surface temperature of the mounting plate exceeds 75 °C (167 °F).
- When installing CRD5103PB, CRD5107PB, CRD5107HPB and CRD5114PB, use either mounting cutout A or B. Do not use both simultaneously.
- When installing CRD5128PB, use either mounting holes or mounting cutouts.

- CRD5103P, CRD5107P, CRD5107HP, CRD5114P

Horizontal installation

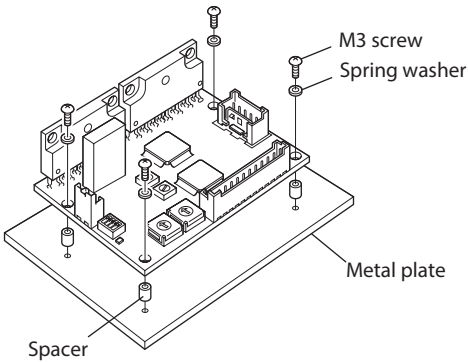

Vertical installation

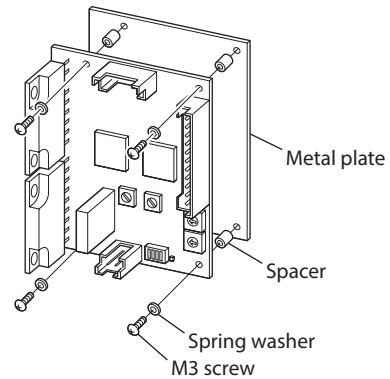

Note

- Do not use any holes on the MOSFET arrays to install the drivers.
- If the surface temperature of the driver's MOSFET array exceeds 90 °C (194 °F), review the operating conditions.
- The case containing the MOSFET arrays is insulated.

6 Connection

This chapter explains the connection methods, connection examples, and I/O signals about the driver and motor, power supply, and controller. Also, it explains the protection against noise and the compliance with the EMC Directive.

A connector-coupled type motor is adopted for the high-resolution type, high-torque type and geared types (**CRK513P**, **CRK523P**). Use the supplied connector leads. Accessories connector leads and driver cable sets (sold separately) are also available. See p.49 for details.

6-1 Connection example

■ NPN type

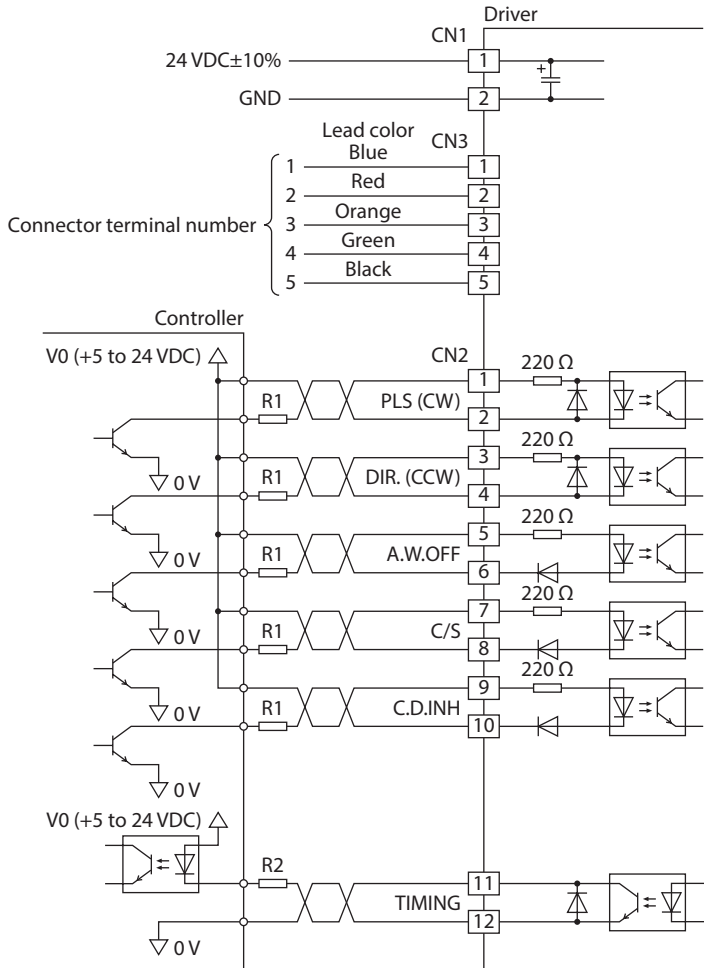

■ PNP type

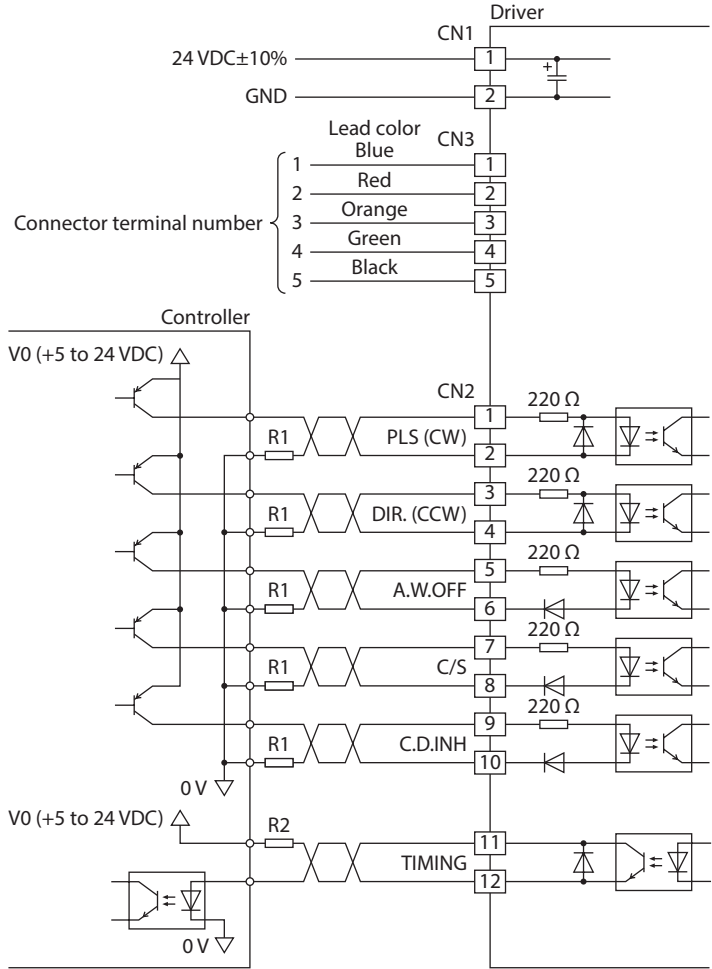

Note

- Use 5 VDC as input signal voltage. If the input signal voltage exceeds 5 VDC, connect an appropriate external resistance R1 in order to keep the input current to 7 to 20 mA.
Example) When V0 is 24 VDC R1: 1.5 to 2.2 k Ω , 0.5 W or more.
- Use the output signal voltage between 5 VDC and 24 VDC, 10 mA or less. When it is above 10 mA, connect R2 to keep the current below 10 mA or less.
- Be certain the I/O signals cable that connects the driver and controller is as short as possible. The maximum input frequency will decrease as the cable length increases.

■ Connector pin assignments for driver

Connector No.	Pin No.	Type	Signal	Description
CN1	1	Input	POWER	+ +24 VDC
	2	Input		- GND
CN2	1	Input	PLS (CW)	+ Pulse input (CW pulse) *1
	2	Input		-
	3	Input	DIR. (CCW)	+ Rotation direction input (CCW pulse) *1
	4	Input		-
	5	Input	A.W.OFF	+ All windings off input
	6	Input		-
	7	Input	C/S	+ Step angle select input
	8	Input		-
	9	Input	C.D.INH	+ Current cutback release input *2
	10	Input		-
	11	Output	TIMING	+ Excitation timing output
	12	Output		-
CN3	1	Output	MOTOR	Blue motor lead
	2	Output		Red motor lead
	3	Output		Orange motor lead
	4	Output		Green motor lead
	5	Output		Black motor lead

*1 When this switch is set to 1-pulse input mode, the inputs are the pulse input (PLS) and the rotation direction input (DIR).

When this switch is set to 2-pulse input mode, the inputs are CW pulse input (CW) and CCW pulse input (CCW).

*2 These signals are used to set the motor current. Refer to p.41 for details.

■ Connector pin assignments for connector-type motor

Terminal No.	1	2	3	4	5
Motor leads color	Blue	Red	Orange	Green	Black

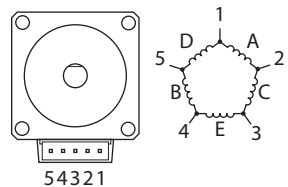

Connect the driver, using the following suitable contacts and connector housings. When crimping contacts for connectors, be sure to use the crimping tool specified by the connector maker. Accessories motor cables and driver cable sets (sold separately) are also available. See p.49 for details.

■ Connector housing, contact and crimping tool for driver

- Manufacturer: Molex Incorporated

Driver model		CRD5103PB, CRD5107PB, CRD5107HPB, CRD5114PB, CRD5103P, CRD5107P, CRD5107HP, CRD5114P	CRD5128PB
For power supply (CN1)	Connector housings	51103-0200	51067-0200
	Contacts	50351-8100	50217-9101
	Specified crimping tool	63811-8100	57189-5000
For I/O signals (CN2)	Connector housings	51103-1200	51103-1200
	Contacts	50351-8100	50351-8100
	Specified crimping tool	63811-8100	57295-5000
For motor (CN3)	Connector housings	51103-0500	51067-0500
	Contacts	50351-8100	50217-9101
	Specified crimping tool	63811-8100	57189-5000

- For the power supply cable, use a cable of AWG22 (0.3 mm²). Keep the wiring distance as short as possible [less than 2 m (6.6 ft.)] to suppress the effect of noise. For CRD5128PB, use a cable of AWG20 (0.5 mm²).
- For the I/O signals cable, use a cable of AWG24 to 22 (0.2 to 0.3 mm²) and keep the wiring distance as short as possible [less than 2 m (6.6 ft.)] to suppress the effect of noise.

Note

- When connecting the cable, be careful regarding the polarity of the power supply. Incorrect power supply polarity could damage the drivers.
- Have the connector plugged in securely. Insecure connection may cause malfunction or damage to the motor or driver.
- When pulling out a connector, pull it out by slightly expanding the latch part of the connectors using a precision screwdriver.
- Always wait at least 5 sec. after switching off the power supply before switching it back on again or connecting/disconnecting the motor cables connector.
- Separate I/O signals cable at least 100 mm (3.94 in.) from electromagnetic relays and other than inductance loads. Additionally, route I/O signals cable perpendicular to power supply cables and motor cables, rather than in a parallel fashion.
- Do not route the power supply cables in the same conduits as other power supply lines and motor cables.
- If the motor cable or power supply cable generates an undesirable amount of noise after wiring/installation, shield the cable or install a ferrite core.

■ Connector housing, contact and crimping tool for motor

- Manufacturer: For PK56□PM J.S.T. Mfg. Co., Ltd.
For other than PK56□PM Molex Incorporated

Motor type	PK513P PK52□P, PK52□HP PK52□PM, PK52□HPM	PK54□P PK54□PM	PK56□PM
Connector housings	51065-0500	51103-0500	VHR-5N
Contacts	50212-8100	50351-8100	BVH-21T-P1.1
Specified crimping tool	63819-0500	63811-8100	AWG22, 20: YC-160R AWG20, 18: YC-161R



- When connecting a connector-type motor, affix the cable at the connection part to prevent the connection part from receiving stress due to the flexing of the cable. Make the cable's radius of curvature as large as possible.
- When disconnecting the connector-type motor cable, pull the connector horizontally along the output shaft to remove. The motor may be damaged if force is applied in any other direction.
- The connector leads that come with the **CRK54□P**, **CRK54□PM** and **CRK56□PM** have a connector with a lock mechanism. When removing this type of cable, release the connector lock first. Forcibly pulling out the cable without releasing the connector lock may damage the motor and connector.

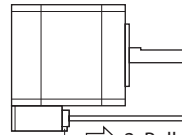

1. Release the lock.
(**CRK54□P**, **CRK54□PM**
and **CRK56□PM** only)
2. Pull out the cable horizontally.

6-3 Connecting the power supply

Use a power supply that can supply the following current capacity.

Driver model	CRD5103PB CRD5103P	CRD5107PB CRD5107HPB CRD5107P CRD5107HP	CRD5114PB CRD5114P	CRD5128PB
Power supply input voltage	24 VDC±10%			
Power supply current capacity	0.7 A or more	1.4 A or more	2.5 A or more	4.3 A or more

6-4 Explanation of I/O signals

Input signals

The signal states indicate the state of the internal photocoupler (ON: power conducted; OFF: power not conducted).

- Example of connection with a current sink output circuit

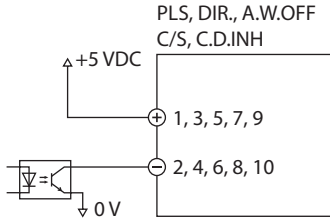

- Example of connection with a current source output circuit

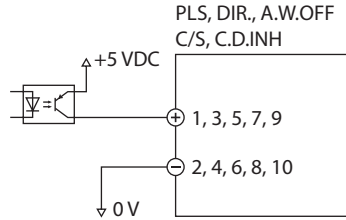

PLS (CW) input and DIR. (CCW) input

This driver can select either 1-pulse input mode or 2-pulse input mode as the pulse input mode to match the controller used. For details on how to set the pulse input mode, see “7-2 Pulse input modes” on p.40.

1-pulse input mode

The controller pulses are connected to the PLS+ input (pin No.1) and the PLS- input (pin No.2), and the rotation direction is connected to the DIR.+ input (pin No.3) and DIR.- input (pin No.4).

- When the DIR. input is ON, a fall of the pulse input from ON to OFF will rotate the motor one step in the CW direction.
- When the DIR. input is OFF, a fall of the pulse input from ON to OFF will rotate the motor one step in the CCW direction.

Use an input pulse signal with a waveform having a sharp rise and fall, as shown in the figure.

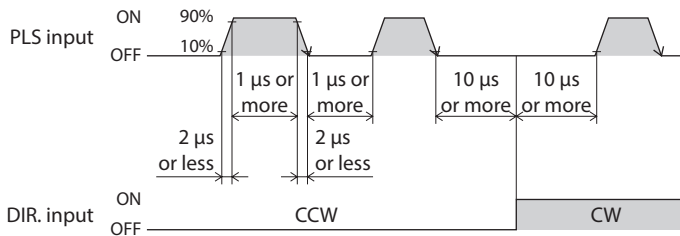

The interval for switching the motor direction represents the response time of the circuit. Set this interval to an appropriate time after which the motor will respond.

2-pulse input mode

The controller's CW pulses are connected to the CW+ (pin No.1) and the CW- (pin No.2), while the CCW pulses are connected to the CCW+ (pin No.3) and the CCW- (pin No.4).

- When the CW pulse input changes from the ON state to OFF state, the motor will rotate one step in the CW direction.
- When the CCW pulse input changes from the ON state to OFF state, the motor will rotate one step in the CCW direction.

Use an input pulse signal with a waveform having a sharp rise and fall, as shown in the figure.

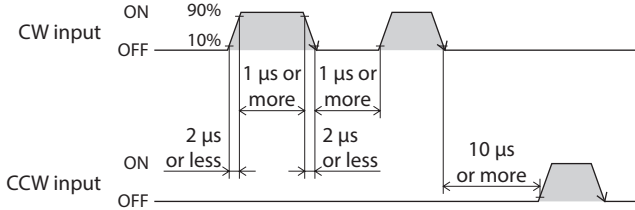

- The interval for switching the motor direction represents the response time of the circuit. Set this interval to an appropriate time after which the motor will respond.
- Always set the photocoupler to OFF when not inputting pulse signals.
- Do not input CW input and CCW input at the same time. If one of these pulses is input when the other is ON the motor will not run properly.

● A.W.OFF (All windings off) input

Use this signal only when the motor's shaft must be rotated mechanically for the purpose of position adjustment.

- When the A.W.OFF input is turned ON, the driver stops supplying current to the motor and the motor's holding torque is lost.
- When the A.W.OFF input is turned OFF, the current supply to the motor resumes, thereby restoring the motor's holding torque.

● C/S (step angle switching) input

This signal selects the step angle set with one of the two step angle setting switches (DATA1 and DATA2).

For example, when DATA1 is set to [0: 0.72°] and DATA2 is set to [6: 0.072°], this signal can switch between 0.72°/step operation and 0.072°/step operation. For details on step angle setting switch, see “7-1 Step angle” on p.38.

- When the C/S input is turned to ON, operation switches to the setting for step angle setting switch DATA2.
- When the C/S input is turned to OFF, operation switches to the setting for step angle setting switch DATA1.

Note

- With the C/S input, the status of selection is read when the power to the driver is turned on.
- Do not switch the C/S input while the motor is operating, or the motor may misstep and stop or cause an offset in position.
- If the C/S input must be used to switch the step angles after the driver power has been turned on, do so while the driver's TIMING output is ON and the motor is at rest. Switching the C/S input under any other condition may disable the TIMING output.

■ Output signals

The driver's output signals are photocoupler/open-collector outputs. The signal states indicate the state of the internal photocoupler (ON: power conducted; OFF: power not conducted).

- Example of connection with a current source output circuit

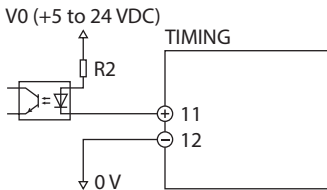

- Example of connection with a current sink output circuit

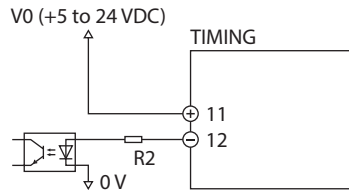

● **TIMING (excitation timing) output**

When the motor excitation state (combined phases of current flowing) is the excitation home position (step 0), the driver switches on the timing output. The motor excitation state is reset to the excitation home position when the power supply is switched on.

When the motor has a base step angle of 0.72°/step, the TIMING output turns ON with a rotation of every 7.2° from the excitation home position in synchronization with a pulse input. The TIMING output behaves differently depending on the combined motor and number of divisions.

Motor type		Number of divisions		TIMING output
		Number of divisions 1	Number of divisions 10	
Standard type High-torque type	Base step angle 0.72°/step	0.72°	0.072°	Every 7.2°
High-resolution type	Base step angle 0.36°/step	0.36°	0.036°	Every 3.6°
Geared type	Geared motor with 7.2:1 gear ratio	0.1°	0.01°	Every 1°

Also, when detecting the mechanical home position for a mechanical device, by making an AND circuit for the mechanical home position sensor and the TIMING output, the variation in the motor stop position within the mechanical home position sensor can be reduced and the mechanical home position made more precise.



- When using the TIMING output, stop the motor's output shaft at an integer multiple of 7.2°.
- When switching the step angle using the C/S input, do this with the motor stopped and the timing output on. If the C/S input is switched in any other condition, the timing output may not turn ON even after the motor has rotated 0.72°.

6-5 Timing chart

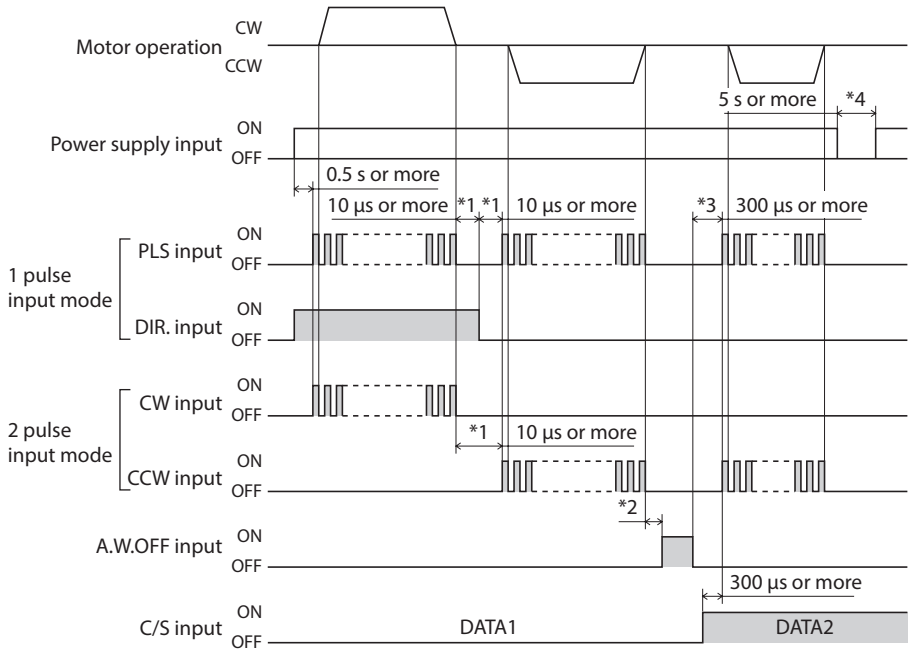

The section indicates that the photocoupler diode is emitting light.

- *1 "10 μs or more" indicated in connection with the DIR. input select time (1-pulse input mode) or CW/CCW input select time (2-pulse input mode) indicates a circuit response time. Set it to the time required for the motor to respond to the applicable pulse input.
- *2 The specific duration varies depending on the load inertial moment, load torque, self-starting frequency, etc.
- *3 Do not input pulse signals immediately after switching the A.W.OFF input to OFF, given that it will affect the motor's starting characteristics.
- *4 After turning off the power supply, wait at least 5 sec. before turning the power supply back on.

6-6 Noise measures

The electrical noise is of two types: One is a noise to invade into the driver from the outside and cause the driver malfunction, and the other is a noise to emit from the driver and cause peripheral equipments malfunction. For the noise that is invaded from the outside, take measures to prevent the driver malfunction. It is needed to take adequate measures because signal lines are very likely to be affected by the noise. For the noise that is emitted from the driver, take measures to suppress it.

■ Measures against electrical noise

There are the following three methods mainly to take measures against the electrical noise.

● Noise suppression

- When relays or electromagnetic switches are used together with the system, use noise filters and CR circuits to suppress surges generated by them.
- Cover the driver by a metal plate such as aluminum. This is effective in shielding the electrical noise emitted from the driver.

● Prevention of noise propagation

- Connect a noise filter on the input side of the DC power supply.
- Place the power lines, such as the motor and power supply cables, keeping a distance of 100 mm (3.94 in.) or more from the signal lines, and also do not bundle them or wire them in parallel. If the power cables and signal cables have to cross, cross them at a right angle.
- Use shielded twisted pair cables of AWG22 (0.3 mm²) [AWG20 (0.5 mm²) for CRD5128PB] or thicker for power lines, and AWG24 (0.2 mm²) or thicker for signal lines.
- Keep cables as short as possible without coiling and bundling extra lengths.
- To ground a shielded cable, use a metal cable clamp that will maintain contact with the entire circumference of the cable. Ground the cable clamp near the product.

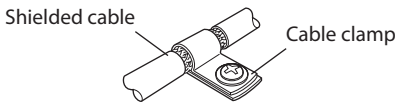

- When grounding PE terminals of multiple drivers to a grounding point, it becomes more effective to block the electrical noise since impedance on the grounding point is decreased. However, ground them so that a potential difference does not occur among the grounding points. An accessory driver cable including with a ground wire is available (sold separately). Refer to p.51 for details.

● Suppression of effect by noise propagation

- Loop the noise propagated cable around a ferrite core. Doing so will prevent the propagated noise invades into the driver or emits from the driver. The frequency band in which an effect by the ferrite core can be seen is generally 1 MHz or more. Check the frequency characteristics of the ferrite core used. To increase the effect of noise attenuation by the ferrite core, loop the cable a lot.
- Change the transmission method of the pulse signal to the line driver type in order to prevent noise effects. When the pulse signal of the controller is the open collector type, use an accessory pulse signal converter for noise immunity. (sold separately). Refer to p.51 for details.

■ Noise suppression parts

● Noise filter

Connect a noise filter (or equivalent) in the table below on the input side of the DC power supply. When a power supply transformer is used, be sure to connect a noise filter on the AC input side of the power supply transformer. Doing so will prevent the propagated noise through the power line. Install the noise filter as close to the input terminals of DC power supply as possible.

Manufacture	Model
SOSHIN ELECTRIC CO.,LTD	HF2010A-UPF
Schaffner EMC	FN2070-10-06

- Use the AWG18 (0.75 mm²) or thicker wire for the input and output cables of the noise filter, and secure firmly using a cable clamp etc. so that the cable does not come off the enclosure.
- Place the input cable as far apart as possible from the output cable, and do not wire the cables in parallel. If the input and output cable are placed at a close distance or if they are wired in parallel, the noise in the enclosure affects the power cable through stray capacitance, and the noise suppressing effect will reduce.
- Connect the ground terminal of the noise filter to the grounding point, using as thick and short a wire as possible.
- When connecting a noise filter in an enclosure, wire the input cable of the noise filter as short as possible. Wiring in long distance may reduce the noise suppressing effect.

■ Noise suppression parts (accessories)

Accessories are sold separately. Refer to p.51 for details.

● Driver cable

This cable is a shielded twisted pair cable for good noise immunity to connect the driver and controller. The ground wires useful to grounding are provided at both ends of the cable. The EMC measures are conducted using the Oriental Motor driver cable.

● Pulse signal converter for noise immunity

This is a noise filter for pulse signal lines. It eliminates the noise of the pulse signal and changes the pulse signal to the line driver type.

● Surge suppressor

This product is effective to suppress the surge which occurs in a relay contact part. Connect it when using a relay or electromagnetic switch. CR circuit for surge suppression and CR circuit module are provided.

6-7 Installing and wiring in compliance with EMC Directive

Effective measures must be taken against the EMI that the motor and driver may give to adjacent control-system equipment, as well as the EMS of the motor and driver itself, in order to prevent a serious functional impediment in the machinery. The use of the following installation and wiring methods will enable the motor and driver to be compliant with the EMC directive. Refer to p.3 for the applicable standards.

Oriental Motor conducts EMC measurements on its motors and drivers in accordance with "Example of installation and wiring."

The user is responsible for ensuring the machine's compliance with the EMC Directive, based on the installation and wiring explained below.

● Connecting the noise filter

Refer to p.35 for details.

● Power supply

The **CRK** Series is a product of DC power input. Use a DC power supply (switched-mode power supply etc.) that conforms to the EMC Directive.

● Connecting the signal

Refer to "Prevention of noise propagation" on p.34.

● How to ground

- The cable used to ground the motor, driver and noise filter must be as thick and short as possible so that no potential difference is generated.
- Choose a large, thick and uniformly conductive surface for the grounding point.
- Install the motor to the grounded metal plate.

● Example of installation and wiring

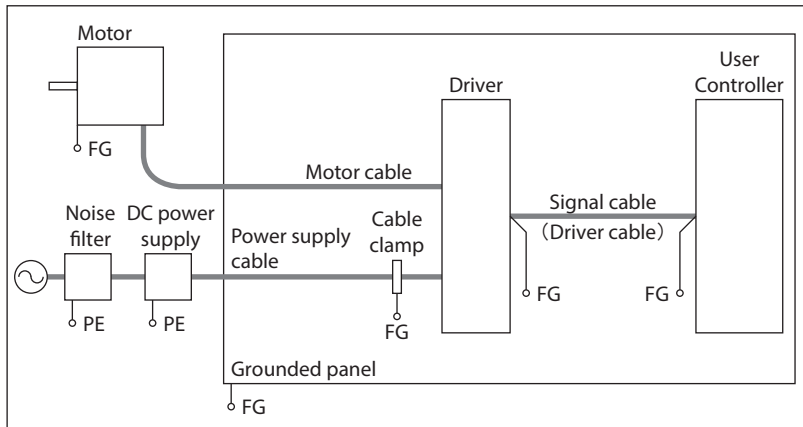

- **Precautions about static electricity**

Static electricity may cause the driver to malfunction or suffer damage.

While the driver is receiving power, handle the driver with care and do not come near or touch the driver.

Always use an insulated screwdriver to adjust the driver's potentiometers.



The driver uses parts that are sensitive to electrostatic charge. Before touching the driver, turn off the power to prevent electrostatic charge from generating. If an electrostatic charge is impressed on the driver, the driver may be damaged.

7 Setting

7-1 Step angle

When setting the motor's step angle, use the resolution select switch and the step angle setting switches [DATA1] [DATA2].

Resolution select switch
Factory setting R1

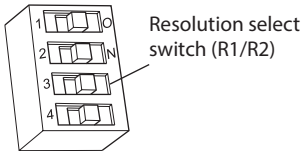

Step angle setting switches
Factory setting DATA1: 0
DATA2: 0

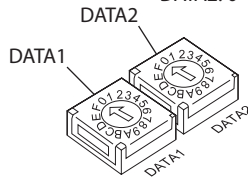

For motors of the base step angle 0.72° , the step angles can be set are shown in the table below.

Resolution select switch: R1

DATA1 or DATA2	Number of divisions	Resolution	Step angle
0	1	500	0.72°
1	2	1000	0.36°
2	2.5	1250	0.288°
3	4	2000	0.18°
4	5	2500	0.144°
5	8	4000	0.09°
6	10	5000	0.072°
7	20	10000	0.036°
8	25	12500	0.0288°
9	40	20000	0.018°
A	50	25000	0.0144°
B	80	40000	0.009°
C	100	50000	0.0072°
D	125	62500	0.00576°
E	200	100,000	0.0036°
F	250	125,000	0.00288°

Resolution select switch: R2

DATA1 or DATA2	Number of divisions	Resolution	Step angle
0	$\times 2.5$	200	1.8°
1	$\times 1.25$	400	0.9°
2	1.6	800	0.45°
3	2	1000	0.36°
4	3.2	1600	0.225°
5	4	2000	0.18°
6	6.4	3200	0.1125°
7	10	5000	0.072°
8	12.8	6400	0.05625°
9	20	10000	0.036°
A	25.6	12800	0.028125°
B	40	20000	0.018°
C	50	25000	0.0144°
D	51.2	25600	0.0140625°
E	100	50000	0.0072°
F	102.4	51200	0.00703125°

- Set to [R1] side when setting to the step angle in the “R1” side of the table.
- Set to [R2] side when setting to the step angle in the “R2” side of the table.

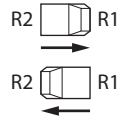

Note

- Step angles are theoretical values.
- With the high-resolution type, the base step angle is set to 0.36° and the resolution to 1000.
- If you are using a geared type, the actual step angle is calculated by dividing the step angle by the gear ratio.

■ How to set step angle

1. Set the resolution select switch to “R1” or “R2”.
R1: Among the step angles shown in the table on the previous page, those corresponding to the resolution select switch setting of “R1” can be used.
R2: Among the step angles shown in the table on the previous page, those corresponding to the resolution select switch setting of “R2” can be used.
2. Set a desired step angle using the step angle setting switches.
You can set different step angles using DATA1 and DATA2.
3. Using the C/S input, select whether to use the step angle corresponding to DATA1 or DATA2 to operate the motor.

Setting example: When switching the step angle between 0.72°/step and 0.09°/step

1. Set the resolution select switch to “R1”.
2. Set the step angle setting switch [DATA1] to “0” and [DATA2] to “5”.
3. To operate the motor at 0.72°/step, turn the C/S input OFF.
To operate the motor at 0.09°/step, turn the C/S input ON.

Note

Do not switch the C/S input or the step angle setting switch while the motor is operating, or the motor may misstep and stall.

7-2 Pulse input modes

Either the 1-pulse or 2-pulse input mode may be selected in accordance with the controller used.

Pulse input mode select switch (1P/2P)

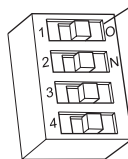

- When the motor is to be controlled through the pulse signal and the rotation direction signal that specifies the motor's direction of rotation, set the to "1P".
- When the motor is to be controlled through 2-pulse signal input via the CW pulse signal and CCW pulse signal, set to "2P".

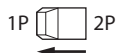

Note The factory setting of the pulse input mode depends on the destination country. Check the pulse input mode setting in accordance with the pulse mode in the controller used.

7-3 Smooth drive function

The smooth drive function achieves low vibration, low noise operation even in full step mode (0.72°). With this function, each full step is automatically divided into 16 microsteps. This provides extremely smooth operation. This function makes it not necessary to change the pulse signals (speed, pulse count) from the controller.

Smooth drive function select switch (OFF/SD)

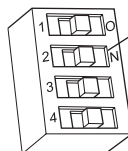

Factory setting SD (smooth drive enable)

The smooth drive function can be used only when the step angle is set to [DATA: 0] though [DATA: 6] for [R1] or [DATA: 0] through [DATA: 7] for [R2]. (The [DATA] value indicates the [DATA1] or [DATA2] setting of the step angle setting switch on p.38.)

- When the smooth drive function is used, set to "SD".
- When the smooth drive function is not used, set to "OFF".

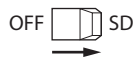

Note The smooth drive function does not work if the step angle is set to a division number greater than 10 (0.072°) *. The [SD] setting is ignored. (The same effect as "OFF".)

* High-resolution type: 0.036°

7-4 Motor current

When the load is light and there is a margin for motor torque, the motor's operating vibration and the temperature increase of the motor and driver can be held down by lowering the motor's operating current and standstill current.

Factory setting RUN: Motor rated current

STOP: About 50% of motor's rated current

■ Connection of current setting DC ammeter

Connect the DC ammeter to the blue motor lead wire and pin No.1 of the driver's CN3 in series.

Do not connect the red motor leads and pin No.2 or black motor leads and pin No.5.

■ Setting the motor operating current

1. Connect a DC ammeter between the motor and driver.
2. Turn the C.D.INH input to ON. Do not apply other input signals.
3. Turn on the driver's power supply (24 VDC).

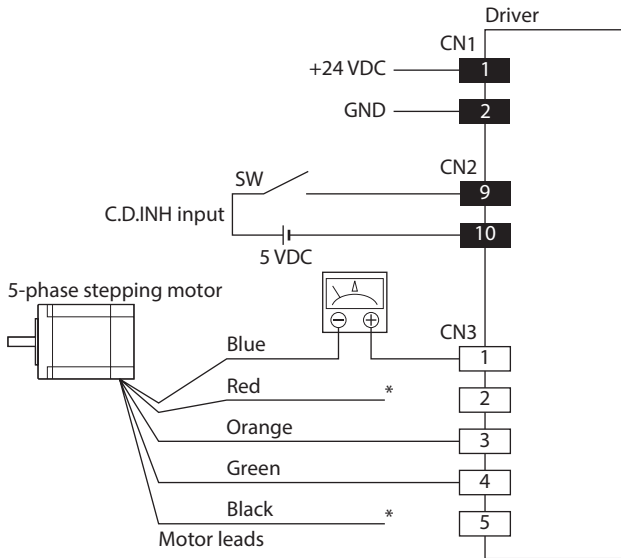

Note

If the red or black motor lead (indicated by *) contacts the other lead, equipment, etc., damage may result. Provide an insulation measure to protect against electric shock.

- Turn the motor operating current potentiometer (RUN) with a precision screwdriver, set the motor operating current.

When the potentiometer is turned counterclock wise, the current decreases.

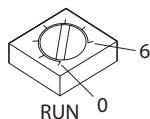

The scale values are not displayed on the control.

CRD5103PB, CRD5103P
(Representative values)

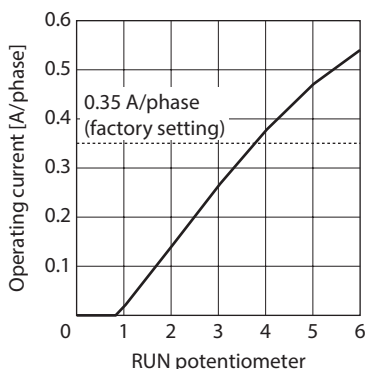

CRD5107PB, CRD5107HPB
CRD5107P, CRD5107HP
(Representative values)

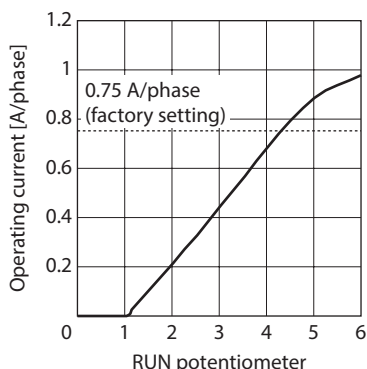

CRD5114PB, CRD5114P
(Representative values)

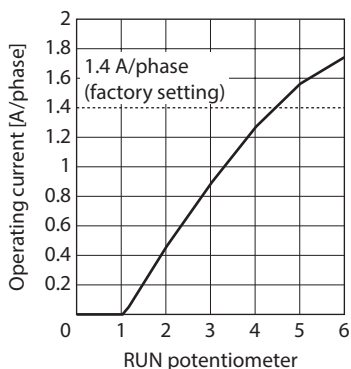

CRD5128PB
(Representative values)

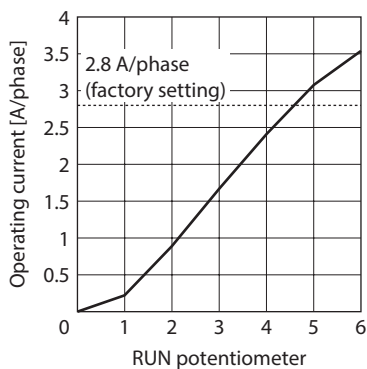

Current corresponding to a dual-phase value flows to the ammeter. A value of one-half that which is indicated equals the single-phase current value.

Example:

- When the indication value on the ammeter shows 1.5 A, it stands for the setting of 0.75 A/phase.
- When the indication value on the ammeter shows 0.7 A, it stands for the setting of 0.35 A/phase.

5. Turn the C.D.INH input to OFF.
6. Continue setting the current while the motor is at a standstill.

■ Setting current at motor standstill

The current at motor standstill is factory set so that it will be about 50% of the motor's operating current (This proportion does not change, even if the motor's operating current is changed).

1. After setting the motor operating current, turn the C.D.INH input to OFF and then input the power supply to the driver.
2. Turn the motor stop current potentiometer (STOP) with a precision screwdriver, setting the current at motor standstill.

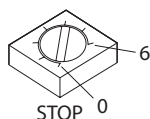

The scale values are not displayed on the control.

CRD5103PB, CRD5103P
(Representative values)

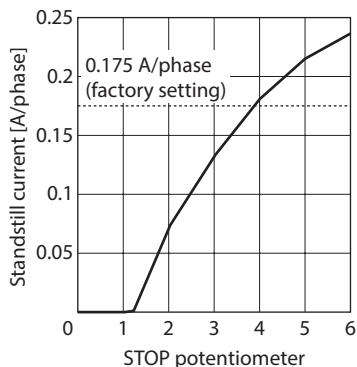

CRD5107PB, CRD5107HPB
CRD5107P, CRD5107HP
(Representative values)

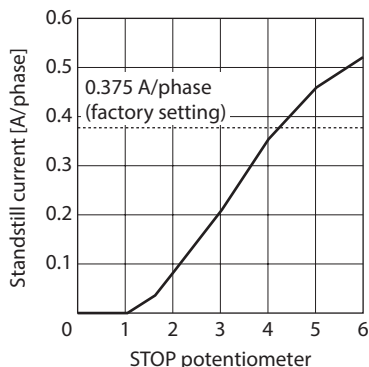

CRD5114PB, CRD5114P
(Representative values)

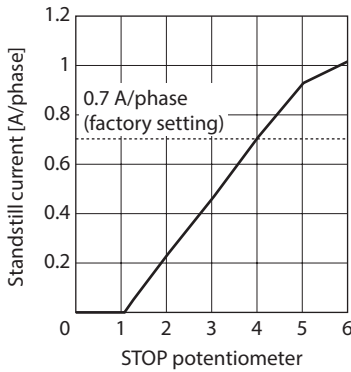

CRD5128PB
(Representative values)

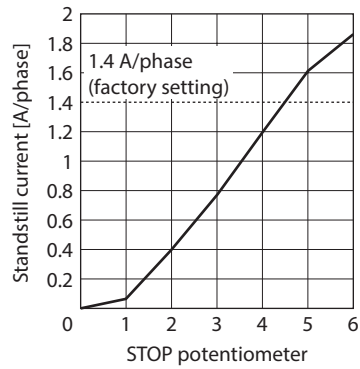

- When the setting is complete, turn off the power supply.
After about 0.1 sec. has passed since the pulse was stopped, the motor's operating current automatically decreases to the set value of current at motor standstill.

Note

- Set the motor's operating current to a value not exceeding the rated current of the motor.
- If the motor current potentiometer is used to adjust current, set the potentiometer graduation to 2 or more. If the potentiometer is set too low, current will become zero and the motor will lose its holding brake torque.
- A range of adjustment of the current at motor standstill is within one-half the set value of motor operating current. When the current at motor standstill is decreased too much, motor starting or maintenance of the location may be hindered. Do not reduce it any more than is necessary.
- When setting the current at motor standstill, be sure to do so after setting the motor's operating current and turning off the power supply to the driver.

8 Inspection

It is recommended that periodic inspections be conducted for the items listed below after each operation of the motor.

If an abnormal condition is noted, stop the use and contact your nearest office.

Inspection items

- Are the motor installation screws loose?
- Are there any abnormal sounds from the motor's bearing section (ball bearings) or elsewhere?
- Do any of the motor leads have damage or stress, or is there any play at the section for connection with the driver?
- Is there any deviation between the centers of the motor's output shaft and load shaft?
- Are the driver installation screws or connector sections loose?
- Is there any dust or dirt on the driver?
- Are there any strange smells or other abnormalities at the driver?



The driver uses semiconductor elements. Handle the driver carefully. There is a danger of the driver being damaged by static electricity, etc.

9 Troubleshooting and remedial actions

During motor operation, the motor or driver may fail to function properly due to an improper speed setting or wiring. When the motor cannot be operated correctly, refer to the contents provided in this section and take appropriate action. If the problem persists, contact your nearest office.

Phenomenon	Possible cause	Remedial action
<ul style="list-style-type: none"> The motor is not energized. The motor's output shaft can be turned easily by hand. 	Connection error in the motor leads or power supply cable.	Check the connections between the driver, motor and power supply.
	Current potentiometer incorrectly set. If the setting is too low, the motor torque will also be too low and operation will be unstable.	Return the current potentiometer to its factory setting and check.
	The A.W.OFF input is set to ON.	Switch the A.W.OFF input to OFF and confirm that the motor is excited.
The motor does not run.	Pulse input line connection error.	<ul style="list-style-type: none"> Check the controller and driver connections. Check the pulse signal specifications (voltage and width).
	The CW input and the CCW input came ON at the same time.	Input either the CW input or the CCW input, and always switch the other terminal to OFF.
The motor rotates in the direction opposite that which is specified.	The CW input and the CCW input are connected in reverse.	Connect the CW pulses to the CW input (pin No. 1 and 2), and CCW pulses to the CCW input (pin No. 3 and 4).
Motor operation is unstable.	Error in the motor's cable connection.	Check the driver and motor connections.
	Current potentiometer incorrectly set. If the setting is too low, the motor torque will also be too low and operation will be unstable.	Return the current potentiometer to its factory setting and check.
	Pulse input line connection error.	<ul style="list-style-type: none"> Check the controller and driver connections. Check the pulse signal specifications (voltage and width).
Motor operating time is longer than the specified time (self-start operation).	Effect of the smooth drive function.	Disable the smooth drive function and check the operation.

Phenomenon	Possible cause	Remedial action
Loss of synchronization during acceleration or running	The centers of the motor's output shaft and load shaft are not aligned.	Check the connection condition of the motor output shaft and load shaft.
	The load or load fluctuation is too high.	Check for large load fluctuations during motor operation. If adjusting the operating pulse speed to low and high torque eliminates the problem, it is necessary to review the load conditions.
	The starting pulse speed is too high.	Lower the starting pulse speed and set it again to a speed at which stable starting is possible.
	The acceleration (deceleration) time is too short.	Lengthen the acceleration (deceleration) time in order to reset it to a time at which stable starting is possible.
	Electrical noise.	Check running with only the motor, driver and required controller. If the impact of noise is recognized, take countermeasures, such as rewiring for greater distance from the noise source, changing the signal cables to shielded wire, or mounting a ferrite core.
Motor does not move the set amount.	Mistake in switching C/S input.	Check the C/S input switching state.
	Wrong step angle settings.	Check the settings of the step angle setting switches [DATA1] and [DATA2].
	Pulse output count is too low or too high.	Check whether or not the number of pulses required for operation at the set step angle are being output.
Current does not drop when the motor stops.	The C.D.INH input is set to ON.	Switch the C.D.INH input to OFF.
	The pulse input remains ON even after pulses have stopped.	After the pulses stop, always switch to OFF.

Phenomenon	Possible cause	Remedial action
Motor vibration too great.	The centers of the motor's output shaft and load shaft are not aligned.	Check the connection condition of the motor output shaft and load shaft.
	Motor resonating.	If the vibration decreases when the operating pulse speed is changed, it means the motor is resonating. Change the operating pulse speed setting. Or install a clean damper (sold separately) to suppress vibration.
	Load too small.	Lower the motor operating current. Vibration will increase if the motor's output torque is too large for the load.
Motor too hot.	Long continuous operation time of the motor.	Decrease the operation time of the motor per session or increase the standstill time. Make sure that the motor case temperature will not exceed 100 °C (212 °F).
	The C.D.INH input is set to ON.	Switch the C.D.INH input to OFF.
	Motor standstill current adjustment too high.	Adjust the motor's standstill current to 50% of the operating current or below.
Driver too hot.	Long continuous operation time of the motor.	Decrease the operation time of the motor per session or increase the standstill time. Make sure the surface temperature of the MOSFET array does not exceed 90°C (194 °F) while the motor is in operation. If the driver is installed with a mounting plate, the surface temperature of the mounting plate should not exceed 75 °C (167 °F).
TIMING output not output.	C/S input switched when TIMING output is OFF.	Switch the C/S input when TIMING output is ON.

10 Accessories (sold separately)

■ Connection cable (for motor)

The lead wires come preassembled with a crimped connector for easy connection of a connector-type motor. [A 0.6 m (2 ft.) connector leads come with the motor and driver package product.]

Model	Length	Conductor	Applicable product
LC5N06A	0.6 m (2 ft.)	AWG24 (0.2 mm ²)	PK513P, PK523P, PK525P, PK523HP, PK525HP, PK523PM, PK524PM, PK525PM, PK523HPM, PK524HPM, PK525HPM, PK523P-T□, PK513P-PS□, PK523P-PS□, PK523P-N□, PK513P-H□S, PK523HP-H□S
LC5N10A	1 m (3.3 ft.)		
LC5N06B	0.6 m (2 ft.)	AWG22 (0.3 mm ²)	PK544P, PK546P, PK544PM, PK546PM
LC5N10B	1 m (3.3 ft.)		
LC5N06C2	0.6 m (2 ft.)		PK564PM, PK566PM, PK569PM
LC5N10C2	1 m (3.3 ft.)		

■ Connection cable set

This is a set of lead wires (for power supply, I/O signals and motor connection; one each) being preassembled a crimped connector that is compatible with the connector of the driver.

Model	Length	Conductor	Applicable product
LCS04SD5	0.6 m (2 ft.)	AWG22(0.3 mm ²)	CRD5103PB, CRD5107PB CRD5107HPB, CRD5114PB CRD5103P, CRD5107P CRD5107HP, CRD5114P
LCS05SD5		For I/O signals: AWG22 (0.3 mm ²) For power supply and motor: AWG20 (0.5 mm ²)	CRD5128PB

■ Motor connector set

A set of connector housings and contacts matching a connector-type motor.
Each bag contains enough housings and contacts for connecting 30 motors.

Model	Applicable motor	Connector housings	Contacts	Applicable cable
CS5N30A	PK513P PK523P PK525P PK523HP PK525HP PK523PM PK524PM PK525PM PK523HPM PK524HPM PK525HPM PK523P-T□ PK513P-PS□ PK523P-PS□ PK523P-N□ PK513P-H□S PK523HP-H□S	51065-0500 *2	50212-8100 *2	AWG30 to 24 *1 (0.05 to 0.2 mm ²) Outer diameter of sheathed cable: ø1.4 mm (ø0.06 in.) or less. Stripped length: 1.3 to 1.8 mm (0.05 to 0.07 in.)
CS5N30B	PK544P PK546P PK544PM PK546PM	51103-0500 *2	50351-8100 *2	AWG28 to 22 *1 (0.08 to 0.3 mm ²) Outer diameter of sheathed cable: ø1.15 to 1.8 mm (ø0.05 to 0.07 in.) Stripped length: 2.3 to 2.8 mm (0.09 to 0.11 in.)
CS5N30C2	PK564PM PK566PM PK569PM	VHR-5N *3	BVH-21T-P1.1 *3	AWG22 to 18 *1 (0.33 to 0.83 mm ²) Outer diameter of sheathed cable: ø1.7 to 3 mm (ø0.07 to 0.12 in.) Stripped length: 3 to 3.5 mm (0.12 to 0.14 in.)

*1 The driver's motor connector (CN3) accepts cables of AWG24 to 22 (0.2 to 0.3 mm²) in size.

*2 Manufacturer: Molex Incorporated

*3 Manufacturer: J.S.T. Mfg. Co., Ltd.

■ Connection cable (for signal)

This is a shielded twisted pair cable for the driver control I/O (12 pins) that has good noise immunity. The ground wires useful to grounding are provided at both ends of the cable.

Model	Length [m (ft)]	Conductor
CC12D005-2	0.5 (1.6)	AWG24 (0.2 mm ²)
CC12D010-2	1 (3.3)	
CC12D015-2	1.5 (4.9)	
CC12D020-2	2 (6.6)	

■ Pulse signal converter for noise immunity

It eliminates the noise of the pulse signal and changes the pulse signal to the line driver type.

Model: **VCS06**

■ CR circuit for surge suppression

This product is effective to suppress the surge which occurs in a relay contact part. Use it to protect the contacts of the relay or switch.

Model: **EPCR1201-2**

■ CR circuit module

This product is effective to suppress the surge which occurs in a relay contact part. Use this product to protect the contacts of the relay or switch.

4 pieces of CR circuit for surge suppression are mounted on the compact circuit, and this product can be installed to the DIN rail. This product can make the wiring easily and securely since it also supports terminal block connection.

Model: **VCS02**

- Unauthorized reproduction or copying of all or part of this manual is prohibited. If a new copy is required to replace an original manual that has been damaged or lost, please contact your nearest Oriental Motor sales office.
- Oriental Motor shall not be liable whatsoever for any problems relating to industrial property rights arising from use of any information, circuit, equipment or device provided or referenced in this manual.
- Characteristics, specifications and dimensions are subject to change without notice.
- While we make every effort to offer accurate information in the manual, we welcome your input. Should you find unclear descriptions, errors or omissions, please contact your nearest Oriental Motor sales office.
- **Orientalmotor** is a registered trademark or trademark of Oriental Motor Co., Ltd., in Japan and other countries. Other product names and company names mentioned in this manual may be registered trademarks or trademarks of their respective companies and are hereby acknowledged. The third-party products mentioned in this manual are recommended products, and references to their names shall not be construed as any form of performance guarantee. Oriental Motor is not liable whatsoever for the performance of these third-party products.

© Copyright ORIENTAL MOTOR CO., LTD. 2010

Published in March 2021

• Please contact your nearest Oriental Motor office for further information.

ORIENTAL MOTOR U.S.A. CORP
Technical Support Tel:800-468-3982
8:30am EST to 5:00pm PST (M-F)
www.orientalmotor.com

ORIENTAL MOTOR (EUROPA) GmbH
Schiessstraße 44, 40549 Düsseldorf, Germany
Technical Support Tel:00 800/22 55 66 22
www.orientalmotor.de

ORIENTAL MOTOR (UK) LTD.
Tel:+44-1256347090
www.oriental-motor.co.uk

ORIENTAL MOTOR (FRANCE) SARL
Tel:+33-1 47 86 97 50
www.orientalmotor.fr

ORIENTAL MOTOR ITALIA s.r.l.
Tel:+39-02-93906347
www.orientalmotor.it

ORIENTAL MOTOR ASIA PACIFIC PTE. LTD.
Singapore
Tel:1800-842-0280
www.orientalmotor.com.sg

ORIENTAL MOTOR (MALAYSIA) SDN. BHD.
Tel:1800-806-161
www.orientalmotor.com.my

ORIENTAL MOTOR (THAILAND) CO., LTD.
Tel:1800-888-881
www.orientalmotor.co.th

ORIENTAL MOTOR (INDIA) PVT. LTD.
Tel:1800-120-1995 (For English)
1800-121-4149 (For Hindi)
www.orientalmotor.co.in

TAIWAN ORIENTAL MOTOR CO., LTD.
Tel:0800-060708
www.orientalmotor.com.tw

SHANGHAI ORIENTAL MOTOR CO., LTD.
Tel:400-820-6516
www.orientalmotor.com.cn

INA ORIENTAL MOTOR CO., LTD.
Korea
Tel:080-777-2042
www.inaom.co.kr

ORIENTAL MOTOR CO., LTD.
4-8-1 Higashiueno, Taito-ku, Tokyo
110-8536 Japan
Tel:+81-3-6744-0361
www.orientalmotor.co.jp