



2-Phase Stepping Motor and Driver Package

CMK Series

OPERATING MANUAL



Thank you for purchasing an Oriental Motor product.

This operating manual describes product handling procedures and safety precautions.

- Please read it thoroughly to ensure safe operation.
- Always keep the manual where it is readily available.

Table of contents

1	Introduction	2	6	Connection	24
1.1	EU Directive	2	6.1	Connection example	24
2	Safety precautions	3	6.2	Connecting the connector and crimping the contacts	28
3	Precautions for use	6	6.3	Connecting the power supply	30
4	Preparation	9	6.4	Connecting the motor	30
4.1	Checking the product	9	6.5	Connecting the I/O	31
4.2	Combinations of motors and drivers	10	6.6	About input/output	32
4.3	Names and functions of parts	13	6.7	Timing chart	35
5	Installation	14	7	Setting	36
5.1	Location for installation	14	7.1	Step angle	36
5.2	Installing the motor	14	7.2	Pulse input mode	37
5.3	Installing a load	16	7.3	Motor current	37
5.4	Permissible radial load and permissible axial load	17	8	Inspection	41
5.5	Installing the driver	19	9	Troubleshooting and remedial actions	42
5.6	Installing and wiring in compliance with EMC Directive	21	10	Options (sold separately)	45

1 Introduction

■ Before use

The product described in this manual has been designed and manufactured for use in general industrial machinery, and must not be used for any other purpose. For the driver's power supply, use a DC power supply with reinforced insulation on its primary and secondary sides. Oriental Motor Co., Ltd. is not responsible for any damage caused through failure to observe this warning.

■ Overview of the product

The **CMK** Series is a motor and driver package consisting of a board-level microstep driver and high-torque designing 2-phase stepping motor or geared type stepping motor.

1.1 EU Directive

■ CE Marking

This product is affixed the CE Marking under the EMC Directive.

Oriental Motor performs the self-declaration of conformity with the EMC Directive for the motor and driver package.

● Low Voltage Directive

The **CMK** Series motors and drivers are not subject to the Low Voltage Directive, since their input power supply voltage is 24 VDC. However, the product must satisfy the following conditions with regard to installation and connection:

- Use the product in a protected environment within an enclosure.
- As for the driver's power supply, use a DC power supply with reinforced insulation on both the primary and secondary sides.

● EMC Directive



This product has received EMC compliance under the conditions specified in "Example of motor and driver installation and wiring" on page 23. The conformance of your mechanical equipment with the EMC Directive will vary depending on such factors as the configuration, wiring, and layout for other control system devices and electrical parts used with this product. It therefore must be verified through conducting EMC measures in a state where all parts including this product have been installed in the equipment.

■ Hazardous substances

The products do not contain the substances exceeding the restriction values of RoHS Directive (2011/65/EU).

2 Safety precautions

The precautions described below are intended to prevent danger or injury to the user and other personnel through safe, correct use of the product. Use the product only after carefully reading and fully understanding these instructions.

 Warning	Handling the product without observing the instructions that accompany a “Warning” symbol may result in serious injury or death.
 Caution	Handling the product without observing the instructions that accompany a “Caution” symbol may result in injury or property damage.
<div style="background-color: black; color: white; padding: 2px; text-align: center;">Note</div>	The items under this heading contain important handling instructions that the user should observe to ensure safe use of the product.

 **Warning**

General

- Do not use the product in explosive or corrosive environments, in the presence of flammable gases, locations subjected to splashing water, or near combustibles. Doing so may result in fire or injury.
- Assign qualified personnel the task of installing, wiring, operating/controlling, inspecting and troubleshooting the product. Failure to do so may result in fire or injury.
- Provide a means to hold the moving parts in place for applications involving vertical travel. The motor loses holding torque when the power is shut off, allowing the moving parts to fall and possibly cause injury or damage to equipment.

Installation

- Install the motor and driver in their enclosures in order to prevent injury.

Connection

- Keep the driver’s power supply input voltage within the specified range to avoid fire.
- For the driver’s power supply use a DC power supply with reinforced insulation on its primary and secondary sides. Failure to do so may result in electric shock.
- Connect the cables securely according to the wiring diagram in order to prevent fire.
- Do not forcibly bend, pull or pinch the power supply cable and motor cable. Doing so may fire.

Operation

- Turn off the driver power supply in the event of a power failure, or the motor may suddenly start when the power is restored and may cause injury or damage to equipment.
- Do not turn the AWO (all windings off) input to ON while the motor is operating. The motor will stop and lose its holding ability, which may result in injury or damage to equipment.

Repair, disassembly and modification

- Do not disassemble or modify the motor or driver. This may cause injury. Refer all such internal inspections and repairs to the branch or sales office from which you purchased the product.



General

- Do not use the motor and driver beyond their specifications, or injury or damage to equipment may result.
- Keep your fingers and objects out of the openings in the motor and driver, or fire or injury.
- Do not touch the motor or driver during operation or immediately after stopping. The surfaces are hot and may cause a burn.
- If the power supply cable or motor cable connected the driver are forcibly bent or pulled, the driver will receive stress and may suffer damage.

Transportation

- Do not hold the motor output shaft or motor cable. This may cause injury.

Installation

- Keep the area around the motor and driver free of combustible materials in order to prevent fire or a burn.
- To prevent the risk of damage to equipment, leave nothing around the motor and driver that would obstruct ventilation.
- Provide a cover over the rotating parts (output shaft) of the motor to prevent injury.

Operation

- Use a motor and driver only in the specified combination. An incorrect combination may cause a fire.
- Provide an emergency stop device or emergency stop circuit external to the equipment so that the entire equipment will operate safely in the event of a system failure or malfunction. Failure to do so may result in injury.
- Before supplying power to the driver, turn all control inputs to the driver to OFF. Otherwise, the motor may start suddenly and cause injury or damage to equipment.

- To prevent bodily injury, do not touch the rotating parts (output shaft) of the motor during operation.
- Before moving the motor directly (as in the case of manual positioning), confirm that the driver AWO (all windings off) input is “ON” to prevent injury.
- Immediately when trouble has occurred, stop running and turn off the driver power supply. Failure to do so may result in fire, electric shock or injury.

Disposal

- To dispose of the motor or driver, disassemble it into parts and components as much as possible and dispose of individual parts/components as industrial waste.

3 Precautions for use

This section covers limitations and requirements the user should consider when using the **CMK** series.

- **Conduct the insulation resistance measurement or withstand voltage test separately on the motor and the driver.**

Conducting the insulation resistance measurement or withstand voltage test with the motor and driver connected may result in injury or damage to equipment.

- **Do not apply a radial load and axial load in excess of the specified permissible limit.**

Be sure to operate the motor within the specified permissible limit of radial load and axial load. Operating it under an excessive radial load and axial load may damage the motor bearings (ball bearings). See page 17 for details.

- **Operate the motor with a surface temperature not exceeding 100 °C (212 °F).**

The motor casing's surface temperature may exceed 100 °C (212 °F) under certain conditions (ambient temperature, operating speed, duty cycle, etc.). Keeping the surface temperature of the motor casing below 100 °C (212 °F) will also maximize the life of the motor bearings (ball bearings).

Use the geared type motor in a condition where the gear case temperature does not exceed 70 °C (158 °F), in order to prevent deterioration of grease and parts in the gear case.

- **About maximum static torque at excitation**

Maximum static torque at excitation represents a value obtained when the motor is excited using the rated current. When the motor is combined with a dedicated driver, the maximum static torque at excitation drops to approximately 40% due to the current cutback function that suppresses the rise in motor temperature in a standstill state. Acceleration and operation at the maximum static torque at excitation is possible in start-up, but it only has approximately 40% holding power after it has stopped. When selecting a motor for your application, consider the fact that the holding power will be reduced to approximately 40% after the motor has stopped.

- **Preventing electrical noise**

See 5.6 "Installing and wiring in compliance with EMC Directive" on page 21 for measures with regard to noise.

- **Check the colors of motor lead wires and connect them correctly and securely.**

Wrong connection of lead wires or poor contact may damage the driver.

- Geared type motors

Backlash

The **SH** gear output shaft is subject to backlash of 1 to 2°, while the **TH** gear output shaft is subject to backlash of 10 to 45'. Backlash refers to the looseness at the gear output shaft, as generated when the input side of the gear is fixed. To reduce the effect of backlash, positioning should be from one direction only either from the CW direction or the CCW direction.

Allowable torque

Operate the motor by making sure the sum of the acceleration/deceleration torque at the starting/stopping of the motor and the load (friction) torque doesn't exceed the allowable torque. Operating the motor in excess of the allowable torque may result in a damaged gear.

Allowable speed range

Operate the motor at speeds within the allowable range. Operating the motor at a speed outside the allowable range may result in a shorter gear life.

Rotating direction of the gear output shaft

The relationship between the rotating direction of the motor shaft and that of the gear output shaft changes as follows, depending on the gear type and gear ratio.

Gear type	Gear ratio	Rotating direction (Relative to the motor rotation direction)		
		Motor size [mm (in.)]		
		28 (1.1)	42 (1.65)	60 (2.36)
SH geared	3.6:1	-	Same direction	
	7.2:1	Same direction		
	9:1 10:1	Opposite direction		
	18:1	Opposite direction	Opposite direction	
	36:1	Same direction		
	50:1 100:1	-	Same direction	
TH geared	3.6:1 7.2:1 10:1	-	Same direction	
	20:1 30:1	-	Opposite direction	

Grease of geared motor

On rare occasions, a small amount of grease may ooze out from the geared motor. If there is concern over possible environmental damage resulting from the leakage of grease, check for grease stains during regular inspections. Alternatively, install an oil pan or other device to prevent leakage from causing further damage. Oil leakage may lead to problems in the customer's equipment or products.

- **Regeneration**

When a large inertial load is operated at high speed, regenerative energy will generate and increase the power supply voltage, which can damage the driver. Review the operating condition and make sure regenerative voltage will not generate.

4 Preparation

This section covers the points to be checked along with the names and functions of the respective parts.

4.1 Checking the product

Upon opening the package, verify that the items listed below are included. Report any missing or damaged items to the branch or sales office from which you purchased the product. See 4.2 “Combinations of motors and drivers” on page 10 for the motor and driver combinations.

- Motor 1 unit
- Driver 1 unit
- Operating manual (this manual) 1 copy
- Motor cable 0.6 m (2 ft.) 1 pc.
- * Motor cables are supplied with high-torque type and geared type (**CMK223SG**).
- Motor mounting screws (**SH** geared type only) 4 pcs.
 - CMK223A(B)P-SG**: M2.5 Cross recessed screw
 - CMK243A(B)P-SG**: M3 Cross recessed screw
 - CMK243A(B)PA-SG**: No.4-40UNC Cross recessed screw
 - CMK264A(B)P-SG**: M4 Hexagonal socket head screw
 - CMK264A(B)PA-SG**: No.8-32UNC Hexagonal socket head screw
- Connector housing/contact 1 set (packed in a bag)

Application	Connector housing (Molex)	Contact (Molex)
Power supply	51103-0200 (2 poles) 1 pc.	50351-8100 35 pcs. (15 pcs. are included as spares.)
I/O signals	51103-1200 (12 poles) 1 pc.	
Motor	51103-0600 (6 poles) 1 pc.	

Note

When removing the driver from the conductive protection bag, make sure your hands are not charged with static electricity. This is to prevent damage to the driver due to static electricity.

4.2 Combinations of motors and drivers

■ High-torque type

Model		Motor model		Driver model
Single shaft	Double shaft	Single shaft	Double shaft	
CMK223PAP	CMK223PBP	PK223PA	PK223PB	CMD2109P
CMK224PAP	CMK224PBP	PK224PA	PK224PB	
CMK225PAP	CMK225PBP	PK225PA	PK225PB	
CMK233PAP	CMK233PBP	PK233PA	PK233PB	CMD2112P
CMK235PAP	CMK235PBP	PK235PA	PK235PB	
CMK244PAP	CMK244PBP	PK244PA	PK244PB	
CMK246PAP	CMK246PBP	PK246PA	PK246PB	
CMK264PAP	CMK264PBP	PK264PA	PK264PB	CMD2120P
CMK266PAP	CMK266PBP	PK266PA	PK266PB	
CMK268PAP	CMK268PBP	PK268PA	PK268PB	
CMK264PAPA	CMK264PBPA	PK264PAA	PK264PBA	
CMK266PAPA	CMK266PBPA	PK266PAA	PK266PBA	
CMK268PAPA	CMK268PBPA	PK268PAA	PK268PBA	

■ High-resolution type

Model		Motor model		Driver model
Single shaft	Double shaft	Single shaft	Double shaft	
CMK243MAP	CMK243MBP	PK243MA	PK243MB	CMD2109P
CMK243MAPA	CMK243MBPA	PK243MAA	PK243MBA	
CMK244MAP	CMK244MBP	PK244MA	PK244MB	CMD2112P
CMK244MAPA	CMK244MBPA	PK244MAA	PK244MBA	
CMK245MAP	CMK245MBP	PK245MA	PK245MB	
CMK245MAPA	CMK245MBPA	PK245MAA	PK245MBA	CMD2120P
CMK264MAP	CMK264MBP	PK264MA	PK264MB	
CMK266MAP	CMK266MBP	PK266MA	PK266MB	
CMK268MAP	CMK268MBP	PK268MA	PK268MB	

■ Standard type

Model		Motor model		Driver model
Single shaft	Double shaft	Single shaft	Double shaft	
CMK243AP	CMK243BP	PK243-01A	PK243-01B	CMD2109P
CMK243APA	CMK243BPA	PK243-01AA	PK243-01BA	
CMK244AP	CMK244BP	PK244-01A	PK244-01B	CMD2112P
CMK244APA	CMK244BPA	PK244-01AA	PK244-01BA	
CMK245AP	CMK245BP	PK245-01A	PK245-01B	
CMK245APA	CMK245BPA	PK245-01AA	PK245-01BA	
CMK256AP	CMK256BP	PK256-02A	PK256-02B	CMD2120P
CMK258AP	CMK258BP	PK258-02A	PK258-02B	
CMK264AP	CMK264BP	PK264-02A	PK264-02B	
CMK266AP	CMK266BP	PK266-02A	PK266-02B	
CMK268AP	CMK268BP	PK268-02A	PK268-02B	

■ SH geared type

Model		Motor model		Driver model
Single shaft	Double shaft	Single shaft	Double shaft	
CMK223AP-SG7.2	CMK223BP-SG7.2	PK223PA-SG7.2	PK223PB-SG7.2	CMD2109P
CMK223AP-SG9	CMK223BP-SG9	PK223PA-SG9	PK223PB-SG9	
CMK223AP-SG10	CMK223BP-SG10	PK223PA-SG10	PK223PB-SG10	
CMK223AP-SG18	CMK223BP-SG18	PK223PA-SG18	PK223PB-SG18	
CMK223AP-SG36	CMK223BP-SG36	PK223PA-SG36	PK223PB-SG36	
CMK243AP-SG3.6	CMK243BP-SG3.6	PK243A1-SG3.6	PK243B1-SG3.6	
CMK243APA-SG3.6	CMK243BPA-SG3.6	PK243A1A-SG3.6	PK243B1A-SG3.6	
CMK243AP-SG7.2	CMK243BP-SG7.2	PK243A1-SG7.2	PK243B1-SG7.2	
CMK243APA-SG7.2	CMK243BPA-SG7.2	PK243A1A-SG7.2	PK243B1A-SG7.2	
CMK243AP-SG9	CMK243BP-SG9	PK243A1-SG9	PK243B1-SG9	
CMK243APA-SG9	CMK243BPA-SG9	PK243A1A-SG9	PK243B1A-SG9	
CMK243AP-SG10	CMK243BP-SG10	PK243A1-SG10	PK243B1-SG10	
CMK243APA-SG10	CMK243BPA-SG10	PK243A1A-SG10	PK243B1A-SG10	
CMK243AP-SG18	CMK243BP-SG18	PK243A1-SG18	PK243B1-SG18	
CMK243APA-SG18	CMK243BPA-SG18	PK243A1A-SG18	PK243B1A-SG18	
CMK243AP-SG36	CMK243BP-SG36	PK243A1-SG36	PK243B1-SG36	
CMK243APA-SG36	CMK243BPA-SG36	PK243A1A-SG36	PK243B1A-SG36	
CMK243AP-SG50	CMK243BP-SG50	PK243A1-SG50	PK243B1-SG50	
CMK243AP-SG100	CMK243BP-SG100	PK243A1-SG100	PK243B1-SG100	

Model		Motor model		Driver model
Single shaft	Double shaft	Single shaft	Double shaft	
CMK264AP-SG3.6	CMK264BP-SG3.6	PK264A2-SG3.6	PK264B2-SG3.6	CMD2120P
CMK264APA-SG3.6	CMK264BPA-SG3.6	PK264A2A-SG3.6	PK264B2A-SG3.6	
CMK264AP-SG7.2	CMK264BP-SG7.2	PK264A2-SG7.2	PK264B2-SG7.2	
CMK264APA-SG7.2	CMK264BPA-SG7.2	PK264A2A-SG7.2	PK264B2A-SG7.2	
CMK264AP-SG9	CMK264BP-SG9	PK264A2-SG9	PK264B2-SG9	
CMK264APA-SG9	CMK264BPA-SG9	PK264A2A-SG9	PK264B2A-SG9	
CMK264AP-SG10	CMK264BP-SG10	PK264A2-SG10	PK264B2-SG10	
CMK264APA-SG10	CMK264BPA-SG10	PK264A2A-SG10	PK264B2A-SG10	
CMK264AP-SG18	CMK264BP-SG18	PK264A2-SG18	PK264B2-SG18	
CMK264APA-SG18	CMK264BPA-SG18	PK264A2A-SG18	PK264B2A-SG18	
CMK264AP-SG36	CMK264BP-SG36	PK264A2-SG36	PK264B2-SG36	
CMK264APA-SG36	CMK264BPA-SG36	PK264A2A-SG36	PK264B2A-SG36	
CMK264AP-SG50	CMK264BP-SG50	PK264A2-SG50	PK264B2-SG50	
CMK264AP-SG100	CMK264BP-SG100	PK264A2-SG100	PK264B2-SG100	

■ TH geared type

Model		Motor model		Driver model
Single shaft	Double shaft	Single shaft	Double shaft	
CMK243AP-T3.6	CMK243BP-T3.6	PK243A1-T3.6	PK243B1-T3.6	CMD2109P
CMK243AP-T7.2	CMK243BP-T7.2	PK243A1-T7.2	PK243B1-T7.2	
CMK243AP-T10	CMK243BP-T10	PK243A1-T10	PK243B1-T10	
CMK243AP-T20	CMK243BP-T20	PK243A1-T20	PK243B1-T20	
CMK264AP-T3.6	CMK264BP-T3.6	PK264A2-T3.6	PK264B2-T3.6	CMD2120P
CMK264AP-T7.2	CMK264BP-T7.2	PK264A2-T7.2	PK264B2-T7.2	
CMK264AP-T10	CMK264BP-T10	PK264A2-T10	PK264B2-T10	
CMK264AP-T20	CMK264BP-T20	PK264A2-T20	PK264B2-T20	
CMK264AP-T30	CMK264BP-T30	PK264A2-T30	PK264B2-T30	

4.3 Names and functions of parts

This section covers the names and functions of parts in the motor and driver.

Motor

(Illustration shows the PK26□ type.)

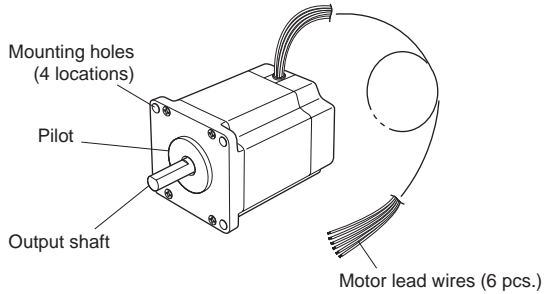

Driver

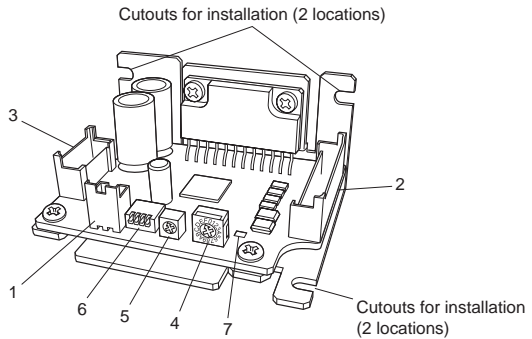

No.	Name	Description
1	Power supply connector (CN1)	Connect to power supply.
2	I/O signals connector (CN2)	Connect to I/O signals.
3	Motor connector (CN3)	Connect to motor.
4	Motor operating current setting switch (RUN)	Set the operating current of the motor. Factory setting: motor's rated current
5	Motor standstill current potentiometer (STOP)	Set the current when the motor is at a standstill. Factory setting: 40% of the rated current
6	Pulse input mode setting switch (SW-1)	Switch the pulse input mode between 1-pulse input mode and 2-pulse input mode.
	Step angle setting switch (SW-2, SW-3, SW-4)	Set a step angle by selecting it from among the 5 step angles.
7	POWER LED	This LED remains lit while the power supply is input (green).

5 Installation

This chapter explains the installation location and installation methods of the motor and driver, as well as how to install a load. The installation and wiring methods in compliance with the EMC Directive are also explained.

5.1 Location for installation

The motor and driver are designed and manufactured for installation in equipment. Install them in a well-ventilated location that provides easy access for inspection. The location must also satisfy the following conditions:

- Inside an enclosure that is installed indoors (provide vent holes)
- Operating ambient temperature
Motor: -10 to +50 °C (+14 to +122 °F) (non-freezing)
Driver: 0 to +40 °C (+32 to +104 °F) (non-freezing)
- Operating ambient humidity 85% or less (non-condensing)
- Area that is free of explosive atmosphere or toxic gas (such as sulfuric gas) or liquid
- Area not exposed to direct sun
- Area free of excessive amount of dust, iron particles or the like
- Area not subject to splashing water (rains, water droplets), oil (oil droplets) or other liquids
- Area free of excessive salt
- Area not subject to continuous vibration or excessive shocks
- Area free of excessive electromagnetic noise (from welders, power machinery, etc.)
- Area free of radioactive materials, magnetic fields or vacuum

5.2 Installing the motor

■ Installation direction

The motor can be installed in any direction.

■ Installation method

Install the motor onto an appropriate flat metal plate having excellent vibration resistance and heat conductivity.

When installing the motor, secure it with four bolts (supplied for **SH** geared type only) through the four mounting holes provided. Do not leave a gap between the motor and metal plate.

Note

- Insert the pilot located on the motor's installation surface into the mounting plate's countersunk or through hole.
- Do not loosen the gearhead attaching screws (4 pcs.)

Installation method A

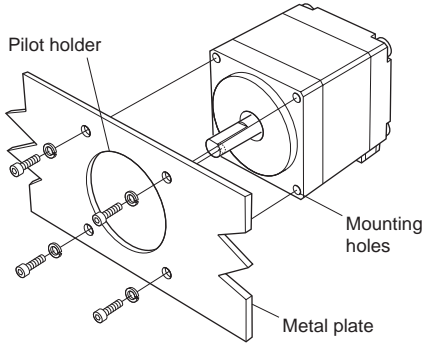

Installation method B

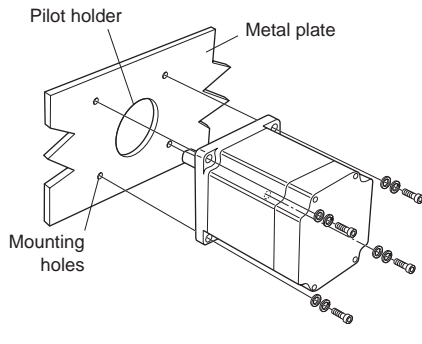

Motor type		Nominal size	Tightening torque [N·m (oz·in)]	Effective depth of bolt [mm (in.)]	Installation method
High-torque type	PK22□P	M2.5	0.5 (71)	2.5 (0.1)	A
	PK23□P	M3	1 (142)	4.5 (0.18)	A
	PK24□P				
	PK26□P	M4 No.8-32UNC	2 (280)	-	B
High-resolution type	PK24□MA(B)	M3	1 (142)	4.5 (0.18)	A
	PK24□MA(B)A	No.4-40UNC	1 (142)	4.5 (0.18)	A
	PK26□M	M4 No.8-32UNC	2 (280)	-	B
Standard type	PK24□-01A(B)	M3	1 (142)	4.5 (0.18)	A
	PK24□-01A(B)A	No.4-40UNC	1 (142)	4.5 (0.18)	A
	PK25	M4 No.8-32UNC	2 (280)	-	B
	PK26				
SH geared type	PK223SG	M2.5	0.5 (71)	4 (0.16)	A
	PK243A(B)1-SG	M3	1 (142)	7 (0.28)	A
	PK243A(B)1A-SG	No.4-40UNC	1 (142)	7 (0.28)	A
	PK264A(B)2-SG	M4	2 (280)	8 (0.31)	A
	PK264A(B)2A-SG	No.8-32UNC	2 (280)	8 (0.31)	A
TH geared type	PK243A(B)1-T	M4	2 (280)	8 (0.31)	A
	PK264A(B)2-T				

5.3 Installing a load

When connecting a load to the motor, align the centers of the motor's output shaft and load shaft. Also, keep the radial load and axial load to the permissible values or below.

- **Using a coupling**

Align the centers of the motor's output shaft and load shaft in a straight line.

- **Using a belt drive**

Align the motor's output shaft and load shaft in parallel with each other, and position both pulleys so that the line connecting their centers is at a right angle to the shafts.

- **Using a gear drive**

Align the motor's output shaft and gear shaft in parallel with each other, and let the gears mesh at the center of the tooth widths.

Note

- When coupling the load to the motor, pay attention to the centering of the shafts, belt tension, parallelism of the pulleys, and so on. Securely tighten the coupling and pulley set screws.
- Be careful not to damage the output shaft or bearings when installing a coupling or pulley to the motor's output shaft.
- Do not modify or machine the motor's output shaft. Doing so may damage the bearings and destroy the motor.

5.4 Permissible radial load and permissible axial load

The radial load and the axial load on the motor's output shaft must be kept under the permissible values listed below.

Note

Failure due to fatigue may occur when the motor bearings and output shaft are subject to repeated loading by a radial or axial load that is in excess of the permissible limit.

Motor type		Permissible radial load [N (lb.)]					Permissible axial load [N (lb.)]
		Distance from the tip of motor's output shaft [mm (in.)]					
		0 (0)	5 (0.20)	10 (0.39)	15 (0.59)	20 (0.79)	
High-torque type	PK223P PK224P PK225P	25 (5.6)	34 (7.6)	52 (11.7)	-	-	5 (1.12)
	PK233P PK235P PK244P PK246P	20 (4.5)	25 (5.6)	34 (7.6)	52 (11.7)	-	10 (2.2)
	PK264P PK266P PK268P	61 (13.7)	73 (16.4)	90 (20)	110 (24)	160 (36)	20 (4.5)
	PK264P□A PK266P□A PK268P□A	49 (11)	60 (13.5)	79 (17.7)	110 (24)	-	
High-resolution type	PK243M PK244M PK245M	20 (4.5)	25 (5.6)	34 (7.6)	52 (11.7)	-	10 (2.2)
	PK264M PK266M PK268M	54 (12.1)	67 (15)	89 (20)	130 (29)	-	20 (4.5)

- Enter A (single shaft) or B (double shaft) in the box (□) within the model name.

Motor type		Permissible radial load [N (lb.)]					Permissible axial load [N (lb.)]
		Distance from the tip of motor's output shaft [mm (in.)]					
		0 (0)	5 (0.20)	10 (0.39)	15 (0.59)	20 (0.79)	
Standard type	PK243 PK244 PK245	20 (4.5)	25 (5.6)	34 (7.6)	52 (11.7)	-	10 (2.2)
	PK256 PK258 PK264 PK266 PK268	54 (12.1)	67 (15)	89 (20)	130 (29)	-	20 (4.5)
SH geared type	PK223SG	15 (3.3)	17 (3.8)	20 (4.5)	23 (5.1)	-	10 (2.2)
	PK243SG	10 (2.2)	15 (3.3)	20 (4.5)	30 (6.7)	-	15 (3.3)
	PK264SG (gear ratio: 3.6 to 10)	30 (6.7)	40 (9)	50 (11.2)	60 (13.5)	70 (15.7)	30 (6.7)
	PK264SG (gear ratio: 18 to 100)	80 (18)	100 (22)	120 (27)	140 (31)	160 (36)	
TH geared type	PK243T	10 (2.2)	14 (3.1)	20 (4.5)	30 (6.7)	-	15 (3.3)
	PK264T	70 (15.7)	80 (18)	100 (22)	120 (27)	150 (33)	40 (9)

5.5 Installing the driver

■ Installation method

When installing the driver in the device, mount it vertically or horizontally.

Installing the driver under conditions other than this could reduce its radiation effect.

Fix the driver directly to the metal enclosure using screws.

The items shown below are necessary in order to mount the driver. (The items are not included and must be provided by the customer.)

- M3 screws 2 pcs.
- M3 spring washers..... 2 pcs.
- M3 washers..... 2 pcs.
- M3 nuts..... 2 pcs. (Not necessary if screw holes are provided in the enclosure.)

There must be a clearance of at least 25 mm (0.98 in.) and 50 mm (1.97 in.) in the horizontal and vertical directions, respectively, between the driver and enclosure or other equipment. When two or more drivers are to be installed side by side, provide 20 mm (0.79 in.) and 50 mm (1.97 in.) clearances in the horizontal and vertical directions, respectively.

Note

- Install the driver in an enclosure.
- Do not install any equipment that generates a large amount of heat near the driver.
- Check ventilation if the ambient temperature of the driver exceeds 40 °C (104 °F). If the surface temperature of the driver's MOSFET array exceeds 85 °C (185 °F), review the operating conditions.
- The case containing the MOSFET arrays is insulated.

Torque the mounting screw (M3) to 0.5 N·m (71 oz-in).

Horizontal installation

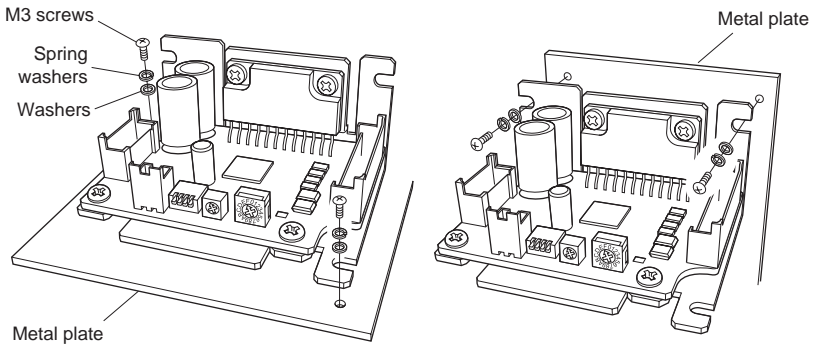

Vertical installation

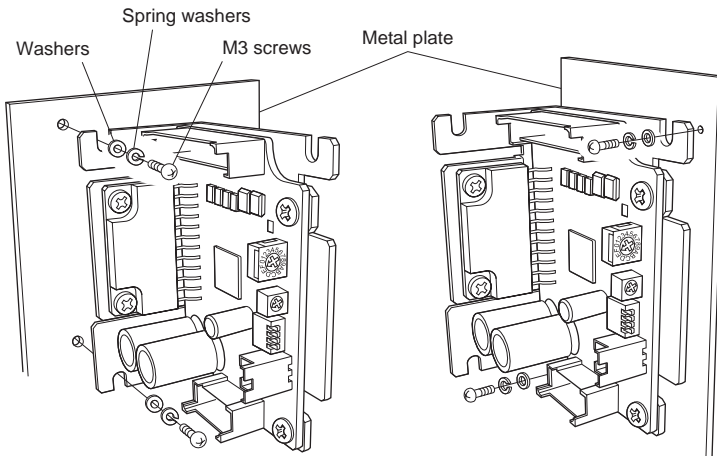

Note When installing the driver vertically, orient the driver so that the power element faces up and the aluminum electrolytic capacitor faces down. If the driver is installed upside down, heat generated by the power element may damage the aluminum electrolytic capacitor.

5.6 Installing and wiring in compliance with EMC Directive

Effective measures must be taken with regard to EMI (electromagnetic interference) caused by the **CMK** series motor and/or driver in the control system equipment operating nearby and EMS (electromagnetic susceptibility) of the **CMK** series motor and/or driver. Failure to do so may result in serious impairment of the machine's functionality.

The use of the following installation and wiring methods will enable the **CMK** series motor and/or driver to be compliant with the EMC Directive.

Oriental Motor conducts EMC measurement of its **CMK** series motors and drivers in accordance with "Example of motor and driver installation and wiring" on page 23. The user is responsible for ensuring the machine's compliance with the EMC Directive, based on the installation and wiring explained below.

Applicable Standards

EMI	EN 55011 EN 61000-6-4
EMS	EN 61000-6-2

■ About power supply

The **CMK** series products are specifically designed for DC power supply input. Use a DC power supply (such as a switching power supply) compliant with the EMC Directive.

■ Mains filter

Connect a mains filter on the input side of the DC power supply so as to prevent the noise generated in the driver from being transmitted externally via the power supply line. When a power supply transformer is used, be sure to connect a mains filter on the AC input side of the power supply transformer. For mains filters, use 10ESK1 (Tyco Electronics CORCOM), ZAG2210-11S (TDK Corporation), or an equivalent.

- Install the mains filter as close to the AC input terminal of DC power supply as possible. Also, secure the I/O cables (AWG18: 0.75 mm² or more) using cable clamps or the like so that the cables won't lift from the surface of the enclosure panel.
- The cable used to ground the mains filter must be as thick and short to the grounding point as possible.
- Do not wire the AC input cable (AWG18: 0.75 mm² or more) and the output cable of the mains filter (AWG18: 0.75 mm² or more) in parallel. If these two cables are wired in parallel, noise inside the enclosure will be connected to the power supply cable via stray capacitance, reducing the effect of the mains filter.

■ Grounding method

When grounding the driver and mains filter, use a cable of the largest possible size and connect to the ground point over the shortest distance so that no potential difference will be generated at the grounded position. The ground point must be a large, thick and uniform conductive surface. Install the motor onto a grounded metal surface.

■ Wiring the power supply cable and I/O signals cable

Use a shielded cable of AWG22 (0.3 mm^2) or more in diameter for the driver power supply cable. Use a shielded cable of AWG24 (0.2 mm^2) or more in diameter for the driver I/O signals cable, and keep it as short as possible.

Use a metal cable clamp that contacts the shielded cable along its entire circumference to secure/ground the power supply cable or I/O signals cable. Attach a cable clamp as close to the end of the cable as possible, and connect it as shown in the figure.

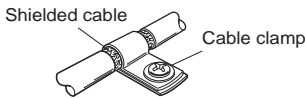

■ Notes about installation and wiring

- Connect the motor, driver and any surrounding control system equipment directly to the grounding point so as to prevent a potential difference from generating between grounds.
- When relays or electromagnetic switches are used together with the system, use mains filters and CR circuits to suppress surges generated by them.
- Keep the cable lengths as short as possible. Do not wind or bundle extra lengths.
- Separate the power supply cables such as motor cable and power supply cable from the signal cables, and wire them apart by around 100 to 200 mm (3.94 to 7.87 in.). If a power source cable must cross over a signal cable, wire them at right angles. Keep an appropriate distance between the AC input cable and output cable of the mains filter.

■ Example of motor and driver installation and wiring

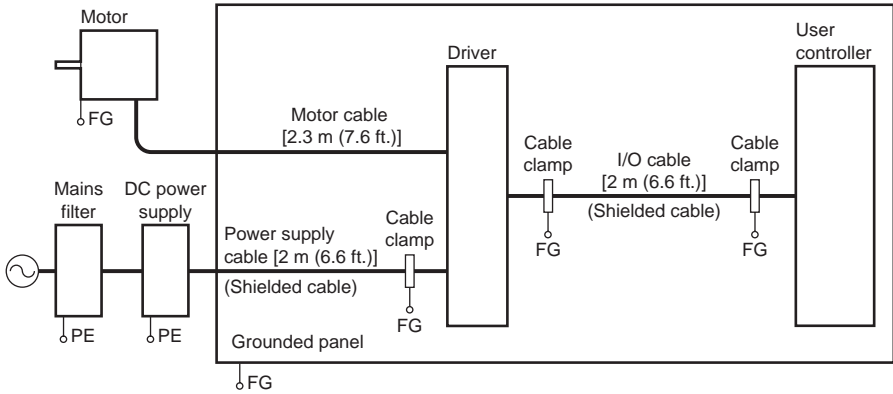

■ Precautions about static electricity

Static electricity may cause the driver to malfunction or suffer damage. Be careful when handling the driver with the power on.

Always use an insulated screwdriver when adjusting the motor current using the control on the driver.

Note

Do not come close to or touch the driver while the power is on.

6 Connection

This section covers the methods of connecting the driver, motor, power supply and controller, as well as the connection examples and I/O signals.

6.1 Connection example

Either 5 or 24 VDC can be used as the signal voltage for the AWO input, CS input and ACDOFF input.

Note Check the colors of motor lead wires and connect them correctly and securely. Wrong connection of lead wires or poor contact may damage the driver.

■ NPN type

- 5 VDC

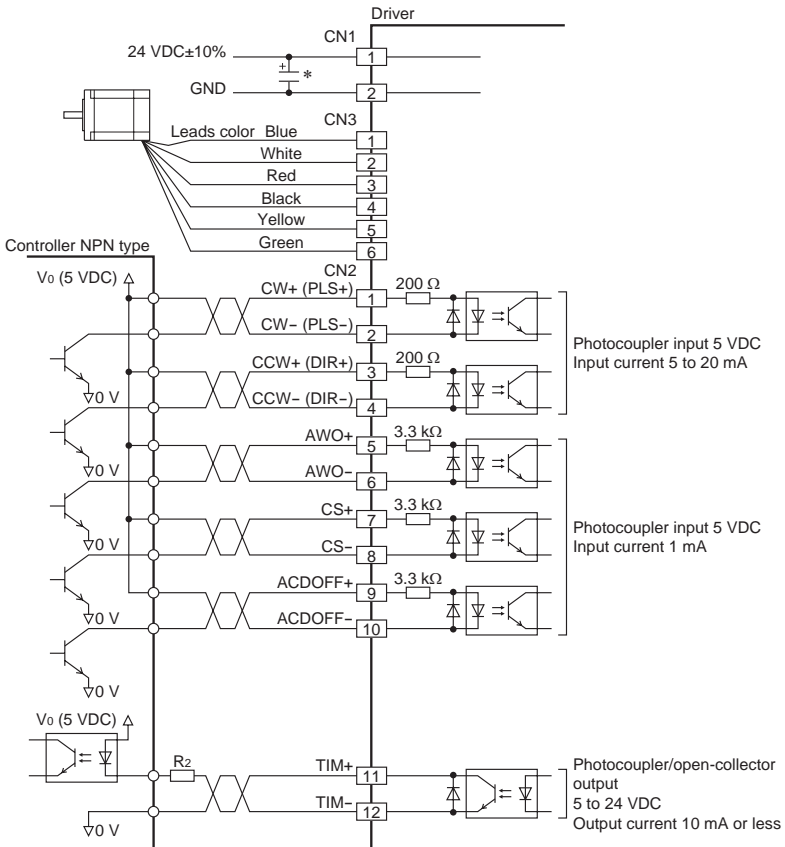

- 24 VDC

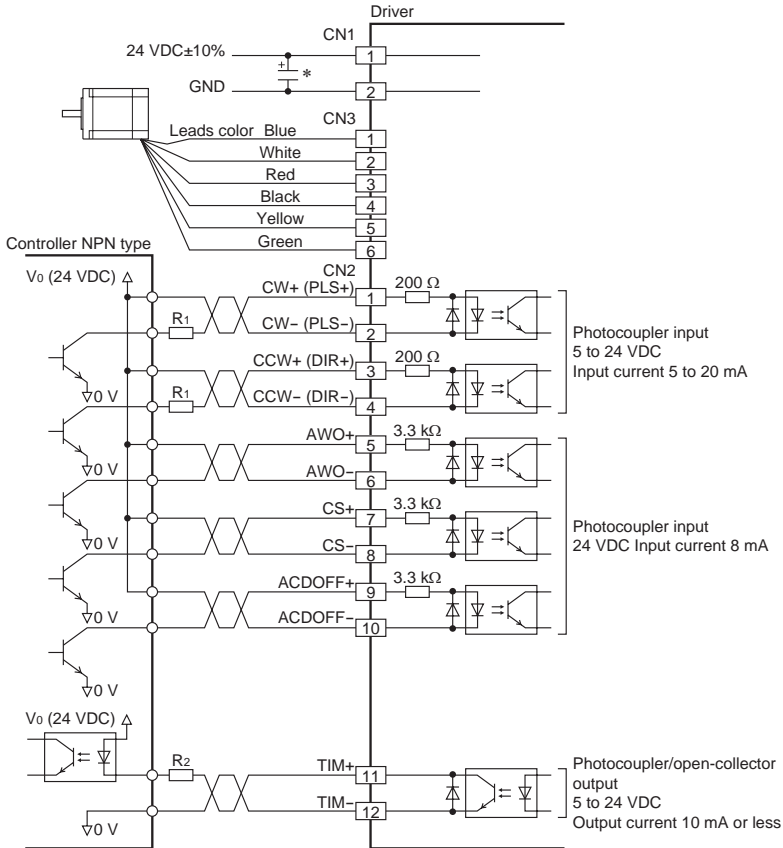
Note

- The CW pulse (pulse) and CCW pulse (rotation direction) inputs are of the 5 VDC input specification. If V_0 exceeds 5 V, connect external resistor R1. Example) When V_0 is 24 VDC R1: 1.5 to 2.2 k Ω , 0.5 W or more.
- If the output signal current exceeds 10 mA, connect external resistor R2 to keep the current to 10 mA or below.
- Be certain the I/O signals cable that connects the driver and controller is as short as possible. The maximum input frequency will decrease as the cable length increases.
- When a large inertial load is operated at high speed, regenerative energy will generate and increase the power supply voltage, which can damage the driver. When performing the operation described above, change the operating conditions so that any temporary rise in supply voltage due to regenerative energy will not exceed 8 V, or connect an electrolytic capacitor* (recommended specifications: 50 V or above in rated voltage and 10000 μ F or above in capacity) to the power supply line in parallel.

■ PNP type

- 5 VDC

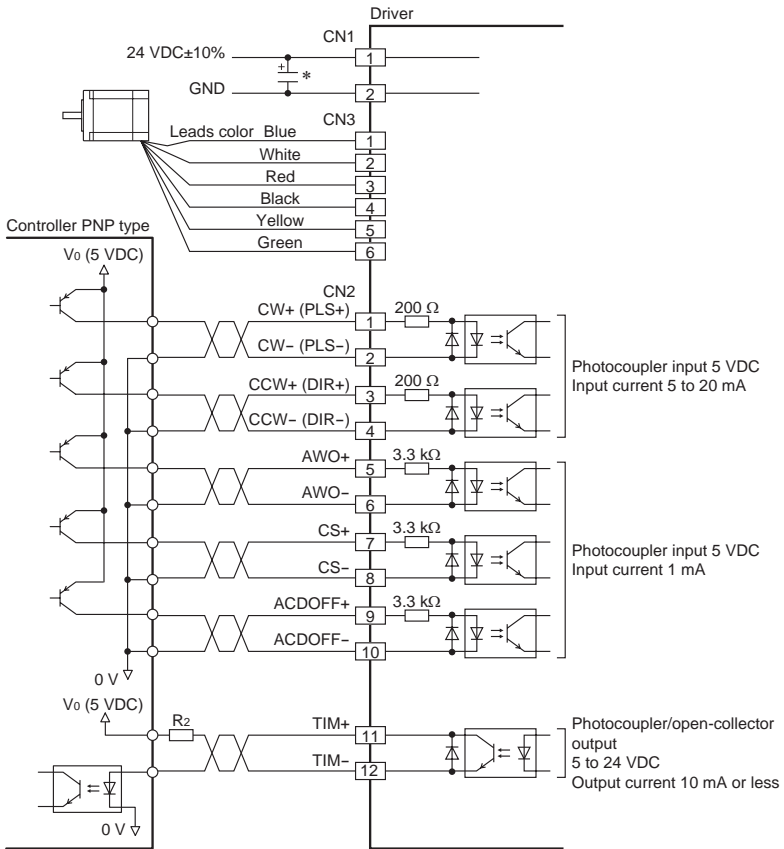

- 24 VDC

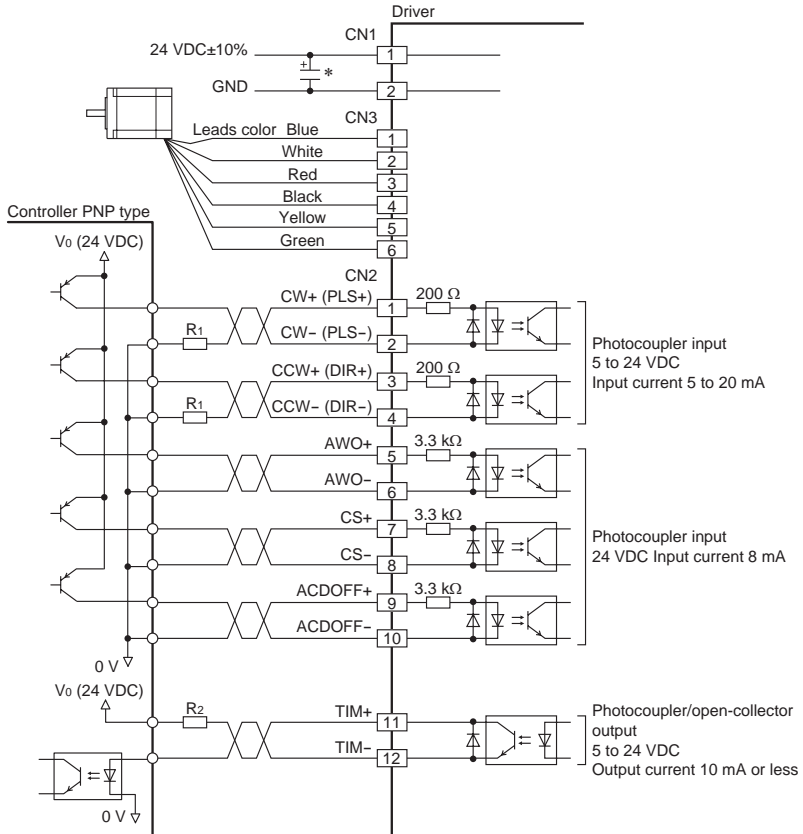
Note

- The CW pulse (pulse) and CCW pulse (rotation direction) inputs are of the 5 VDC input specification. If V_0 exceeds 5 V, connect external resistor R_1 . Example) When V_0 is 24 VDC R_1 : 1.5 to 2.2 k Ω , 0.5 W or more.
- If the output signal current exceeds 10 mA, connect external resistor R_2 to keep the current to 10 mA or below.
- Be certain the I/O signals cable that connects the driver and controller is as short as possible. The maximum input frequency will decrease as the cable length increases.
- When a large inertial load is operated at high speed, regenerative energy will generate and increase the power supply voltage, which can damage the driver. When performing the operation described above, change the operating conditions so that any temporary rise in supply voltage due to regenerative energy will not exceed 8 V, or connect an electrolytic capacitor* (recommended specifications: 50 V or above in rated voltage and 10000 μF or above in capacity) to the power line in parallel.

6.2 Connecting the connector and crimping the contacts

Connect the power supply, motor and I/O signals to the driver by using the supplied connector housing and contacts. Optional motor cables and driver cables (sold separately) are also available. See page 45 for details.

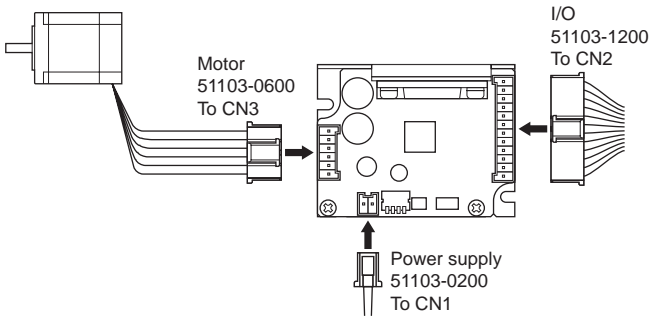

- High-torque type and geared type (**CMK223SG**)

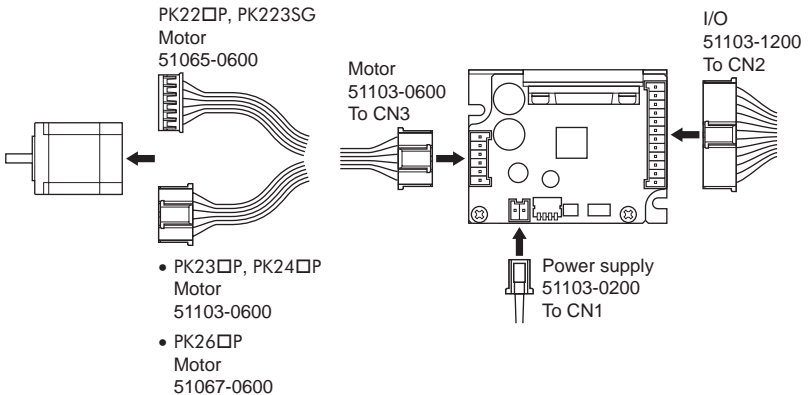

Note

- When connecting a motor, affix the cable at the connection part to prevent the connection part from receiving stress due to the flexing of the cable. Make the cable's radius of curvature as large as possible.
- Have the connector plugged in securely. Insecure connection may cause malfunction or damage to the motor or driver.
- When pulling out a connector, pull it out by slightly expanding the latch part of the connectors using a precision screwdriver.
- Always wait at least 5 seconds after switching off the power supply before switching it back on again or connecting/disconnecting the motor cables connector.

■ Connector housings and contacts (supplied)

When crimping contacts for connectors, be sure to use the crimping tool specified by the connector maker.

Application	Connector housing	Contact	Crimping tool
Power supply (CN1)	51103-0200: 2 poles (Molex)	50351-8100 (Molex)	57295-5000 (Molex)
I/O signals (CN2)	51103-1200: 12 poles (Molex)		
Motor (CN3)	51103-0600: 6 poles (Molex)		

Note

When connecting a motor, affix the cable at the connection part to prevent the connection part from receiving stress due to the flexing of the cable. Make the cable's radius of curvature as large as possible.

■ Suitable cable

Power supply cable

Use a cable of AWG22 (0.3 mm²).

Keep the wiring distance as short as possible [less than 2 m (6.6 ft.)] to suppress the effect of noise.

I/O signals cable

Use a cable of AWG24 to 22 (0.2 to 0.3 mm²).

Keep the wiring distance as short as possible [less than 2 m (6.6 ft.)] to suppress the effect of noise.

Note

- Separate I/O signals cable at least 100 mm (3.94 in.) from electromagnetic relays and other than inductance loads. Additionally, route I/O signals cable perpendicular to power supply cables and motor cables, rather than in a parallel fashion.
- If the motor cable or power supply cable generates an undesirable amount of noise, shield the cable or install a ferrite core.

6.3 Connecting the power supply

Connecting the power supply to the driver's CN1.

Use a power supply that can supply the following current capacity.

Driver model	CMD2109P	CMD2112P	CMD2120P
Power supply input voltage	24 VDC±10%		
Power supply current capacity	1.5 A or more	1.7 A or more	2.9 A or more

CN1 pin assignments

Pin No.	Signal name	Description
1	POWER+	DC power supply input
2	POWER-	GND

Note

- Pay attention to polarity when connecting the power supply. Connecting the power supply in reverse polarity may damage the driver.
- Do not wire the driver's power supply cable in the same conduit in which another power supply line or the motor cable is wired.

6.4 Connecting the motor

Connecting the motor lead wires to the driver's CN3.

With a high-torque type or geared type (**CMK223SG**), use the supplied motor cable.

CN3 pin assignments

Pin No.	Signal name	Description
1	BLUE	Blue motor lead
2	WHITE	White motor lead
3	RED	Red motor lead
4	BLACK	Black motor lead
5	YELLOW	Yellow motor lead
6	GREEN	Green motor lead

Note

- Check the colors of motor lead wires and connect them correctly and securely. Wrong connection of lead wires or poor contact may damage the driver.

■ Connector type motor

With a high-torque type or geared type (**CMK223SG**), a connector is also used for connection on the motor side. Use the supplied motor cable.

If the supplied motor cable is not used, make connection by aligning the motor pin numbers and driver pin numbers.

Note

- When disconnecting the connector type motor cable, pull the connector horizontally along the output shaft to remove. The motor may be damaged if force is applied in any other direction.
- The motor cables that come with the high-torque type **CMK23□P**, **CMK24□P** and **CMK26□P** have a connector with a lock mechanism. When removing this type of cable, release the connector lock first. Forcibly pulling out the cable without releasing the connector lock may damage the motor and connector.

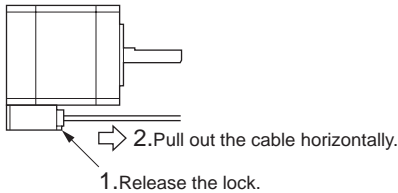

6.5 Connecting the I/O

Connecting the I/O signals to the driver's CN2.

CN2 pin assignments

Pin No.	Signal name	Description
1	CW+ (PLS+) input	CW pulse (pulse) input *
2	CW- (PLS-) input	
3	CCW+ (DIR+) input	CCW pulse (rotation direction) input *
4	CCW- (DIR-) input	
5	AWO+ input	All windings off input
6	AWO- input	
7	CS+ input	Step angle switching input
8	CS- input	
9	ACDOFF+ input	Auto current down release input
10	ACDOFF- input	
11	TIM+ output	Excitation timing output
12	TIM- output	

* When 2-pulse input mode, the inputs are CW pulse and CCW pulse.
When 1-pulse input mode, the inputs are the pulse and the rotation direction.

6.6 About input/output

■ Input signals

The signal state represents the “ON: Carrying current” or “OFF: Not carrying current” state of the internal photocoupler.

- Example of connection with a current sink output circuit

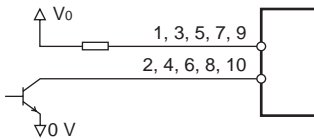

- Example of connection with a current source output circuit

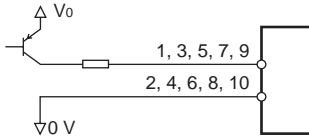

Note

The CW pulse (pulse) input and CCW pulse (rotation direction) input are of the 5 VDC input specification. If V_0 exceeds 5 V, connect an external resistor. Failure to do so may damage the elements.

The AWO input, CS input and ACDOFF input can be connected directly to 5 VDC or 24 VDC.

- CW pulse (PLS) input, CCW pulse (DIR) input

This driver can select either 1-pulse input mode or 2-pulse input mode as the pulse input mode to match the controller used. For details on how to set the pulse input mode, see 7.2 “Pulse input mode” on page 37.

2-pulse input mode

The controller’s CW pulses are connected to the CW+ (pin No.1) or the CW- (pin No.2), while the CCW pulses are connected to the CCW+ (pin No.3) or the CCW- (pin No.4).

- When the CW pulse input changes from the ON to OFF, the motor will rotate one step in the CW direction.
- When the CCW pulse input changes from the ON to OFF, the motor will rotate one step in the CCW direction.

Use an input pulse signal with a waveform having a sharp rise and fall, as shown in the figure:

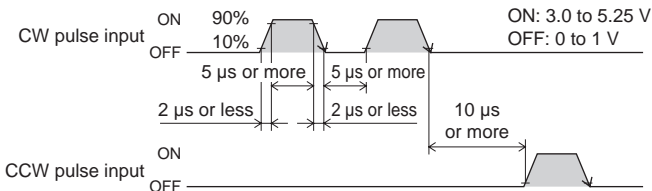

Note

- The interval for switching the motor direction represents the response time of the circuit. Set this interval to an appropriate time after which the motor will respond.
- Always set the photocoupler to OFF when not inputting pulse signals.
- Do not input CW pulse input and CCW pulse input at the same time. If one of these pulses is input when the other is ON the motor will not run properly.

1-pulse input mode

The controller pulses are connected to the PLS+ input (pin No.1) or the PLS- input (pin No.2), and the rotation direction is connected to the DIR+ input (pin No.3) or DIR- input (pin No.4).

- When the DIR input is ON, a fall of the PLS input from ON to OFF will rotate the motor one step in the CW direction.
- When the DIR input is OFF, a fall of the PLS input from ON to OFF will rotate the motor one step in the CCW direction.

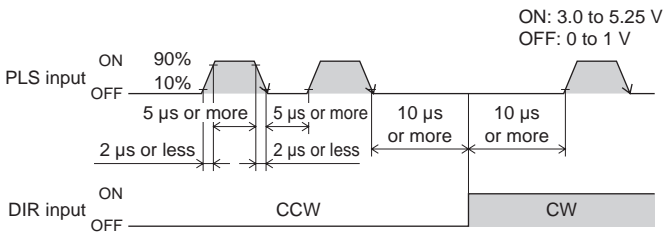
**Note**

The interval for switching the motor direction represents the response time of the circuit. Set this interval to an appropriate time after which the motor will respond.

- **AWO (All windings off) input**

Use the signal only when the motor's output shaft must be rotated manually for position adjustment (ON: 4.5 to 26.4 V, OFF: 0 to 1 V.)

- When the AWO input is turned ON, the driver stops supplying current to the motor and the motor's holding torque is lost. You to adjust the load position manually.
- When the AWO input is turned OFF, the current supply to the motor resumes, thereby restoring the motor's holding torque.

- **CS (step angle switching) input**

(ON: 4.5 to 26.4 V, OFF: 0 to 1 V)

- When the CS input is turned ON, the motor will operate at the base step angle regardless of the settings of the step angle setting switches.
- When the CS input is turned OFF, the motor will operate at the step angle set by the step angle setting switches.

- **ACDOFF (Auto current down release) input**

When the ACDOFF input is turned OFF, the motor current will automatically drop to the standstill current in approx. 0.1 second after the stopping of pulse output. This mechanism suppresses heat generation from the motor or driver while the motor is at standstill.

Keep the ACDOFF input OFF in normal conditions of use.

(ON: 4.5 to 26.4 V, OFF: 0 to 1 V)

■ Output signals

Driver output signals are photocoupler/open-collector output. The signal state represents the “ON: Carrying current” or “OFF: Not carrying current” state of the internal photocoupler.

- Example of connection with a current source input circuit

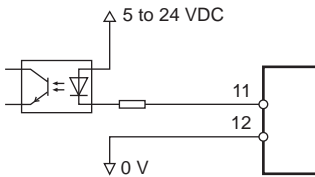

- Example of connection with a current sink input circuit

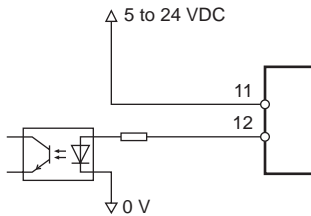

- **TIM (Excitation timing) output**

When the motor excitation state (combined phases of current flowing) is the excitation home position (step 0), the driver switches on the timing output. The motor excitation state is reset to the excitation home position when the power supply is switched on.

When the motor has a base step angle of 1.8°/step, the TIM output turns ON with a rotation of every 7.2° from the excitation home position in synchronization with a pulse input. The TIM output behaves differently depending on the combined motor and number of divisions.

Example of TIM output

Motor type	Number of divisions		TIM output
	1	4	
Motor with 1.8°/step base step angle	1.8°	0.45°	Every 7.2°
Motor with 0.9°/step base step angle	0.9°	0.225°	Every 3.6°
Geared motor with 18 : 1 gear ratio	0.1°	0.025°	Every 0.4°

Also, when detecting the mechanical home position for a mechanical device, by making an AND circuit for the mechanical home position sensor and the TIM output, the variation in the motor stop position within the mechanical home position sensor can be reduced and the mechanical home position made more precise.

Note

- When using the TIM output, stop the motor's output shaft at an integer multiple of 7.2° .
- When switching the step angle, do this with the motor stopped and the TIM output ON.

6.7 Timing chart

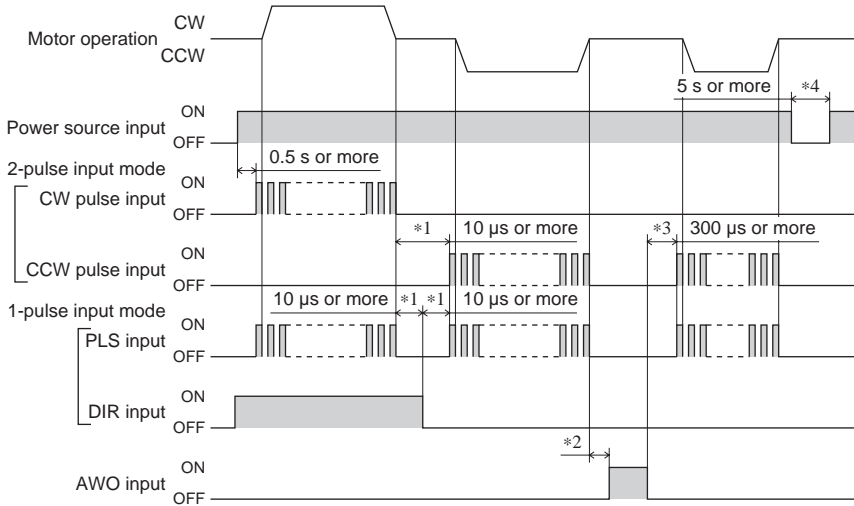

The shaded section indicates that the photocoupler diode is emitting light.

- *1 “ $10 \mu\text{s}$ or more” indicated in connection with the CW/CCW pulse select time (2-pulse input mode) or direction signal select time (1-pulse input mode) indicates a circuit response time. Set it to the time required for the motor to respond to the applicable pulse input.
- *2 The specific duration varies depending on the load inertial moment, load torque, starting frequency, etc.
- *3 Do not input pulse signals immediately after switching the AWO input to OFF, given that it will affect the motor's starting characteristics.
- *4 After turning off the power supply, wait at least 5 seconds before turning the power supply back on.

Note

The maximum response frequency is 100 kHz at a pulse duty of 50%.

7 Setting

7.1 Step angle

Set the motor step angle using the step angle setting switches (SW-2, SW-3, SW-4).

Factory setting: OFF (Number of divisions 1)

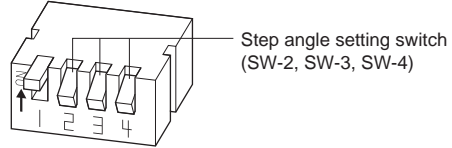

The three step angle setting switches are used together to set five step angles.

Use an insulated precision screwdriver to change the ON/OFF positions of SW-2, SW-3 and SW-4.

The ON/OFF combinations of SW-2, SW-3 and SW-4 and corresponding step angles are shown below.

When the base step angle is 1.8°/step

SW-2	SW-3	SW-4	Number of divisions	Resolution	Step angle
OFF	OFF	OFF	1	200	1.8°
OFF	OFF	ON	2	400	0.9°
OFF	ON	OFF	4	800	0.45°
OFF	ON	ON	8	1600	0.225°
ON	OFF	OFF	16	3200	0.1125°

The step angle is calculated by dividing the base step angle by the number of divisions.

If the switches are set to any combination other than those listed in the table above, the number of divisions will become 1 and the motor will operate at the base step angle.

Note

- Step angles are theoretical values.
- With the high-resolution type, the base step angle is set to 0.9° and the resolution to 400 (number of divisions: 1).
- With the geared type, the actual step angle is calculated by dividing the step angle by the gear ratio.
- The step angle set by the step angle setting switches becomes effective when the CS input is OFF.
- Do not switch the CS input or the step angle setting switch while the motor is operating, or the motor may misstep and stall. Set the step angle setting switches when the CS input is OFF and TIM output is ON.

7.2 Pulse input mode

Either the 1-pulse or 2-pulse input mode may be selected in accordance with the controller used.

Use an insulated precision screwdriver to change the ON/OFF position of the pulse input mode setting switch (SW-1).

Note

The factory setting of the pulse input mode depends on the destination country. Check the pulse input mode setting in accordance with the pulse mode in the controller used.

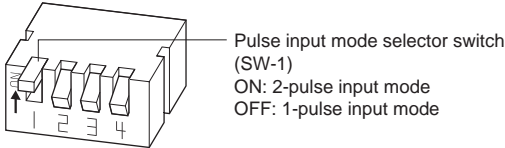

- When the motor is to be controlled through the CW pulse and CCW pulse, set the pulse input mode setting switch to ON.
- When the motor is to be controlled through the pulse and the rotation direction signal, set the pulse input mode setting switch to OFF.

7.3 Motor current

Set the motor current using the motor operating current setting switch (RUN) and motor standstill current potentiometer (STOP).

When the load is light and there is a margin for motor torque, the motor's operating vibration and the temperature increase of the motor and driver can be held down by lowering the motor's operating current and standstill current.

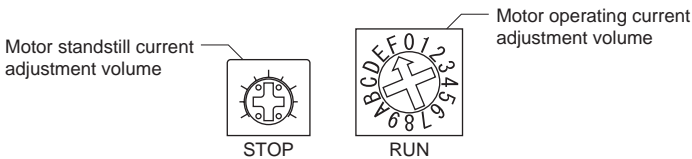

■ Operation current

The motor operating current setting switch (RUN) can be used to set the 16 operating current levels.

Factory setting: F (motor's rated current)

Dial setting	Operating current (A/phase) [Representative values]		
	CMD2109P	CMD2112P	CMD2120P
0	0.12	0.29	0.58
1	0.15	0.36	0.68
2	0.28	0.41	0.77
3	0.33	0.47	0.87
4	0.38	0.54	0.96
5	0.43	0.59	1.05
6	0.49	0.66	1.15
7	0.54	0.72	1.24
8	0.59	0.78	1.35
9	0.64	0.84	1.44
A	0.7	0.9	1.53
B	0.75	0.96	1.62
C	0.8	1.02	1.71
D	0.85	1.08	1.8
E	0.9	1.14	1.9
F	0.95	1.2	2

Note

- The maximum value of the motor's operating current is set as its rated current.
- The actual operating current may vary from the applicable value in the table depending on the motor used.

■ Standstill current

Set the motor standstill current using the motor standstill current potentiometer (STOP).

The motor standstill current is the motor operating current multiplied by current cutback ratio.

Factory setting: 40% of the rated current

Note

- A range of adjustment of the current at motor standstill is within 40% of motor operating current. When the current at motor standstill is decreased too much, motor starting or maintenance of the location may be hindered. Do not reduce it any more than is necessary.
- When operating the potentiometer, use a precision screwdriver.
- When setting the current at motor standstill, be sure to do so after setting the motor's operating current and turning off the power supply to the driver.

Setting method

Set the motor standstill current using ammeters.

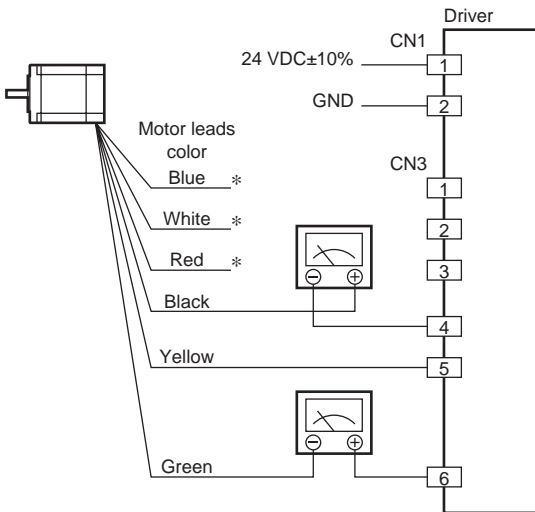

Note

- Check the colors of motor lead wires and connect them correctly and securely. Wrong connection of lead wires or poor contact may damage the driver.
- Damage result if the blue, white and red (*) motor lead wires are touched. Provide an insulation measure to protect against electric shock.

1. Connect a DC ammeter to motor.
2. Turn on the driver's power supply.
3. Use an insulated precision screwdriver to turn the motor standstill current potentiometer (STOP) to adjust the standstill current.
The sum of readings on two ammeters represents the current for one phase.

CMD2109P [Representative values]

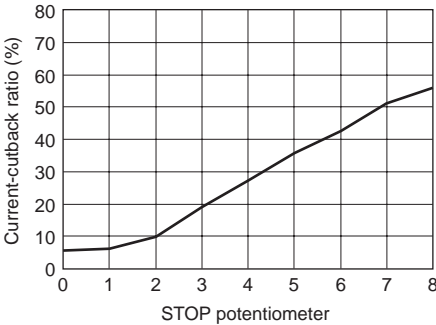

CMD2112P [Representative values]

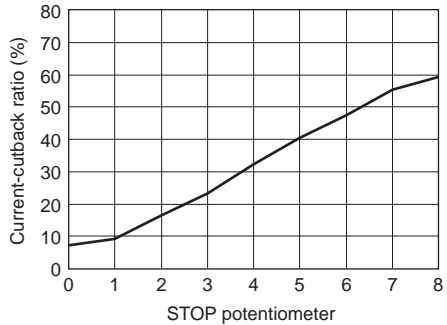

CMD2120P [Representative values]

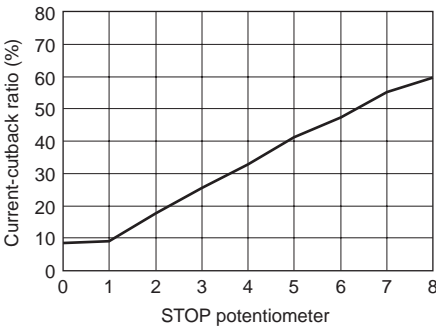

Example: Use CMD2109P at an operating current of 0.95 A/phase.

When the motor standstill current potentiometer (STOP) is set to “2,” the applicable standstill current is calculated as follows:

$$0.95 \text{ A/phase} \times 10\% = \text{Approx. } 0.095 \text{ A/phase}$$

When the potentiometer is set to “7,” the applicable standstill current is calculated as follows:

$$0.95 \text{ A/phase} \times 51\% = \text{Approx. } 0.48 \text{ A/phase}$$

4. When the setting is complete, turn off the power supply.
After about 0.1 second has passed since the pulse was stopped, the motor's operating current automatically decreases to the set value of current at motor standstill.

8 Inspection

It is recommended that periodic inspections be conducted for the items listed below after each operation of the motor.

If an abnormal condition is noted, stop the use and contact your nearest office.

Inspection items

- Are the motor installation screws loose?
- Are there any abnormal sounds from the motor's bearing section (ball bearings) or elsewhere?
- Do any of the motor lead wires have damage or stress, or is there any play at the section for connection with the driver?
- Is there any deviation between the centers of the motor's output shaft and load shaft?
- Are the driver installation screws or connector sections loose?
- Is there any dust or dirt on the driver?
- Are there any strange smells or other abnormalities at the driver?

Note

The driver uses semiconductor elements. Handle the driver carefully. There is a danger of the driver being damaged by static electricity, etc.

9 Troubleshooting and remedial actions

During motor operation, the motor or driver may fail to function properly due to an improper speed setting or wiring. When the motor cannot be operated correctly, refer to the contents provided in this section and take appropriate action. If the problem persists, contact your nearest office.

Phenomenon	Possible cause	Remedial action
<ul style="list-style-type: none"> The motor is not energized. The motor's output shaft can be turned easily by hand. 	Connection error in the motor or power supply.	Check that the connections between the driver, motor and power supply are correct.
	Current potentiometer incorrectly set. If the setting is too low, the motor torque will also be too low and operation will be unstable.	Return the current potentiometer to its factory setting and check.
	The AWO input is set to ON.	Switch the AWO input to OFF and confirm that the motor is excited.
The motor does not run.	Pulse input line connection error.	<ul style="list-style-type: none"> Check the controller and driver connections. Check the pulse input specifications (voltage and width).
	The CW input and the CCW input came ON at the same time.	Input either the CW input or the CCW input, and always switch the other terminal to OFF.
The motor rotates in the direction opposite that which is specified.	The CW input and the CCW input are connected in reverse.	Connect the CW pulses to the CW pulse input (pin No.1 and 2), and connect the CCW pulses to the CCW pulse input (pin No.3 and 4).
Motor operation is unstable.	Motor connection error.	Check that the driver and motor connections are correct.
	Current potentiometer incorrectly set. If the setting is too low, the motor torque will also be too low and operation will be unstable.	Return the current potentiometer to its factory setting and check.

Phenomenon	Possible cause	Remedial action
Loss of synchronization during acceleration or running.	The centers of the motor' output shaft and load shaft are not aligned.	Check the connection condition of the motor output shaft and load shaft.
	The load or load fluctuation is too high.	Check for large load fluctuations during motor operation. If adjusting the motor's operating speed to low and high torque eliminates the problem, it is necessary to review the load conditions.
	The speed of the starting pulse is too high.	Lower the speed of the starting pulse.
	The acceleration (deceleration) time is too short.	Lengthen the acceleration (deceleration) time.
	Electrical noise.	Check running with only the motor, driver and required controller. If the impact of noise is recognized, take countermeasures, such as rewiring for greater distance from the noise source, changing the signal cables to shielded wire, or mounting a ferrite core.
Motor does not move the set amount.	Mistake in switching CS input.	Check the CS input state.
	Wrong step angle settings.	Check the settings of the step angle setting switches.
	Pulse output count is too low or too high.	Check whether or not the number of pulses required for operation at the set step angle are being output.
Current does not drop when the motor stops.	The ACDOFF input is set to ON.	Switch ACDOFF input to OFF.

9 Troubleshooting and remedial actions

Phenomenon	Possible cause	Remedial action
Motor vibration is too loud.	The centers of the motor's output shaft and load shaft are not aligned.	Check the connection condition of the motor output shaft and load shaft.
	Motor is resonating.	If the vibration decreases when the operating pulse speed is changed, it means the motor is resonating. Change the operating pulse speed setting or install a clean damper (sold separately) to suppress vibration.
	Load is too small.	Turn the motor operating current setting switch slightly in the counterclockwise direction in order to lower the current. Vibration will increase if the motor's output torque is too large for the load.
Motor is too hot.	Long continuous operation time of the motor.	Decrease the operation time of the motor per session or increase the standstill time. Make sure that the motor case temperature will not exceed 100 °C (212 °F).
	The ACDOFF input is set to ON.	Switch ACDOFF input to OFF.
	Motor standstill current adjustment is too high.	Lower the motor standstill current.
TIM output does not work.	CS input switched to ON when TIM output is not being output.	Switch the CS input to ON when TIM output is being output.

10 Options (sold separately)

■ Motor cable

Used for connecting the motor of the high-torque type or geared type
(**CMK223SG**.)

Model	Length	Applicable product
LC2U06A	0.6 m (2 ft.)	CMK22□P, CMK223SG
LC2U10A	1 m (3.3 ft.)	
LC2U06B	0.6 m (2 ft.)	CMK23□P, CMK24□P
LC2U10B	1 m (3.3 ft.)	
LC2U06C	0.6 m (2 ft.)	CMK26□P
LC2U10C	1 m (3.3 ft.)	

■ Connector set

Used for connecting the motor of the high-torque type or geared type
(**CMK223SG**.) The cables are not included and must be provided by the customer.

Connector set model	CS2U30A	CS2U30B
Applicable product	CMK22□P, CMK223SG	CMK23□P, CMK24□P
Connector housing	51065-0600 (Molex) 30 pcs.	51103-0600 (Molex) 30 pcs.
Contact	50212-8100 (Molex) 180 pcs.	50351-8100 (Molex) 180 pcs.
Applicable cable	AWG30 to 24 (0.05 to 0.2 mm ²) Cable outer diameter: Ø1.4 mm (0.055 in.) or less Stripping the cable: 1.3 to 1.8 mm (0.051 to 0.071 in.)	AWG28 to 22 (0.08 to 0.3 mm ²) Cable outer diameter: Ø1.15 to 1.8 mm (0.045 to 0.071 in.) Stripping the cable: 2.3 to 2.8 mm (0.091 to 0.11 in.)
Crimping tool	57176-5000 (Molex)	57295-5000 (Molex)

■ Driver cable

A set of 3 cables is provided to connect the power supply, I/O and motor, respectively.

Model: **LCS01CMK2** [0.6 m (2 ft.)]

10 Options (sold separately)

- Unauthorized reproduction or copying of all or part of this manual is prohibited.
- If a new copy is required to replace an original manual that has been damaged or lost, please contact your nearest Oriental Motor branch or sales office.
- Oriental Motor shall not be liable whatsoever for any problems relating to industrial property rights arising from use of any information, circuit, equipment or device provided or referenced in this manual.
- Characteristics, specifications and dimensions are subject to change without notice.
- While we make every effort to offer accurate information in the manual, we welcome your input. Should you find unclear descriptions, errors or omissions, please contact the nearest office.
- ***Oriental motor*** is a registered trademark or trademark of Oriental Motor Co., Ltd., in Japan and other countries.

Other product names and company names mentioned in this manual may be trademarks or registered trademarks of their respective companies and are hereby acknowledged. The third-party products mentioned in this manual are recommended products, and references to their names shall not be construed as any form of performance guarantee. Oriental Motor is not liable whatsoever for the performance of these third-party products.

© Copyright ORIENTAL MOTOR CO., LTD. 2008

• Please contact your nearest Oriental Motor office for further information.

ORIENTAL MOTOR U.S.A. CORP
 Technical Support Tel:(800)468-3982
 8:30 A.M. to 5:00 P.M., P.S.T. (M-F)
 7:30 A.M. to 5:00 P.M., C.S.T. (M-F)
www.orientalmotor.com

ORIENTAL MOTOR DO BRASIL LTDA.
 Tel:+55-11-3266-6018
www.orientalmotor.com.br

ORIENTAL MOTOR (EUROPA) GmbH
 Schiessstraße 74, 40549 Düsseldorf, Germany
 Technical Support Tel:00 800/22 55 66 22
www.orientalmotor.de

ORIENTAL MOTOR (UK) LTD.
 Tel:01256-347090
www.oriental-motor.co.uk

ORIENTAL MOTOR (FRANCE) SARL
 Tel:01 47 86 97 50
www.orientalmotor.fr

ORIENTAL MOTOR ITALIA s.r.l.
 Tel:02-93906346
www.orientalmotor.it

ORIENTAL MOTOR ASIA PACIFIC PTE. LTD.
 Singapore
 Tel:1800-8420280
www.orientalmotor.com.sg

ORIENTAL MOTOR (MALAYSIA) SDN. BHD.
 Tel:1800-806161
www.orientalmotor.com.my

ORIENTAL MOTOR (THAILAND) CO., LTD.
 Tel:1800-888-881
www.orientalmotor.co.th

ORIENTAL MOTOR (INDIA) PVT. LTD.
 Tel:+91-80-41125586
www.orientalmotor.co.in

TAIWAN ORIENTAL MOTOR CO., LTD.
 Tel:0800-060708
www.orientalmotor.com.tw

SHANGHAI ORIENTAL MOTOR CO., LTD.
 Tel:400-820-6516
www.orientalmotor.com.cn

INA ORIENTAL MOTOR CO., LTD.
 Korea
 Tel:080-777-2042
www.inaom.co.kr

ORIENTAL MOTOR CO., LTD.
 Hong Kong Branch
 Tel:+852-2427-9800

ORIENTAL MOTOR CO., LTD.
 4-8-1 Higashiueno, Taito-ku, Tokyo
 110-8536 Japan
 Tel:03-6744-0361
www.orientalmotor.co.jp