



OPERATING MANUAL

Brushless Motor

BLM Motor Connector Type

With Electromagnetic Brake



Introduction

■ Before using the product

Only qualified personnel of electrical and mechanical engineering should work with the product. Use the product correctly after thoroughly reading the section "Safety precautions." In addition, be sure to observe the contents described in warning, caution, and note in this manual. The product described in this manual has been designed and manufactured to be incorporated in general industrial equipment. Do not use for any other purpose. Oriental Motor Co., Ltd. is not responsible for any damage caused through failure to observe this warning.

■ Related operating manuals

Operating manuals for this product are listed below. Operating manuals are not included with the product. Download from Oriental Motor Website Download Page or contact your nearest Oriental Motor sales office.

	Operating manual name
Motor	BLM Motor Connector Type With Electromagnetic Brake OPERATING MANUAL (this document)
Driver	BLE2 Series OPERATING MANUAL

For other descriptions, refer to the operating manual of the driver.

Safety precautions

The precautions described below are intended to ensure the safe and correct use of the product, and to prevent the customer and others from exposure to the risk of injury. Use the product only after carefully reading and fully understanding these instructions.

WARNING	Handling the product without observing the instructions that accompany a "WARNING" symbol may result in serious injury or death.
CAUTION	Handling the product without observing the instructions that accompany a "CAUTION" symbol may result in injury or property damage.
Note	The items under this heading contain important handling instructions that the user should observe to ensure safe use of the product.

[Description of graphic symbols]	Indicates "prohibited" actions that must not be performed.
	Indicates "compulsory" actions that must be performed.

WARNING	
	<ul style="list-style-type: none"> Do not use the product in explosive or corrosive environments, in the presence of flammable gases or near combustibles. Doing so may result in fire, electric shock or injury. Do not transport, install, connect or inspect the product while the power is supplied. Always turn off the power before carrying out these operations. Electric shock or damage to equipment may result. Use an electromagnetic brake motor in an application of vertical drive such as elevating equipment. If a power failure occurs or the driver protective function is activated in a state where the motor without an electromagnetic brake is used, the moving part may fall when the motor stops. This may cause injury or damage to equipment. When using the electromagnetic brake motor in an application of vertical drive (elevating application), be sure check the load condition sufficiently before operating. If a load in excess of the rated torque is applied or the small torque limiting value is set, the load may fall. This may cause injury or damage to equipment.

Thank you for purchasing an Oriental Motor product. This Operating Manual describes product handling procedures and safety precautions.

- Please read it thoroughly to ensure safe operation.
- Always keep the manual where it is readily available.

WARNING	
	<ul style="list-style-type: none"> Do not machine or modify the connection cable. Doing so may result in fire, electric shock, or damage to equipment. Do not apply any excessive force to the motor connector. Doing so may result in fire, electric shock, or damage to equipment. Do not forcibly bend, pull or pinch the cable. Doing so may result in fire, electric shock, or damage to equipment. Do not remove the connector cap until the connection cable is connected so that the O-ring of the connector for cable connection on the motor is not damaged. Doing so may result in fire, electric shock, or damage to equipment. Do not touch the motor or driver when conducting the insulation resistance measurement or dielectric strength test. Accidental contact may result in electric shock. Do not disassemble or modify the motor and gearhead. Refer all such internal inspections and repairs to the branch or sales office from which you purchased the product. This may result in electric shock, injury or damage to equipment.
	<ul style="list-style-type: none"> Only qualified and educated personnel should be allowed to perform installation, connection, operation and inspection/troubleshooting of the product. Handling by unqualified and uneducated personnel may result in fire, electric shock, injury, or damage to equipment. The motor is Class I equipment. When installing the motor and driver, connect their Protective Earth Terminals. Failure to do so may result in electric shock. Use a motor, gearhead, and driver only in the specified combination. Failure to do so may result in fire, electric shock, or damage to equipment. Always turn off the power before performing maintenance or inspection. Failure to do so may result in electric shock.

CAUTION	
	<ul style="list-style-type: none"> Do not use the motor and gearhead beyond the specifications. Doing so may result in fire, electric shock, injury or damage to equipment. Do not touch the motor or gearhead while operating or immediately after stopping. The surface of the motor or gearhead is hot and it may cause a skin burn(s). Do not leave anything around the motor that would obstruct ventilation. Doing so may result in damage to equipment. Do not lift up the product by holding the output shaft of the motor or the gearhead, or the motor cable. Doing so may result in injury. Do not touch the motor output shaft (end or pinion) with bare hands. Doing so may cause injury. When assembling the motor (pinion shaft) with the gearhead, exercise caution not to pinch your fingers or other parts of your body between the motor and gearhead. Injury may result. When installing the motor or gearhead in equipment, exercise caution not to pinch your fingers or other parts of your body between the equipment and motor or gearhead. Injury may result. Do not touch the rotating part (output shaft) while operating the motor. Doing so may cause injury.
	<ul style="list-style-type: none"> Securely install the motor and gearhead to the mounting plate. Inappropriate installation may cause the motor and gearhead to detach and fall, resulting in injury or damage to equipment. Provide a cover over the rotating part (output shaft) of the motor or gearhead. Failure to do so may result in injury. Securely install a load on the output shaft of the motor or gearhead. Inappropriate installation may result in injury. Be sure to ground the motor and driver to prevent them from being damaged by static electricity. Failure to do so may result in fire or damage to equipment. The motor surface temperature may exceed 70°C (158°F) even under normal operating conditions. If the operator is allowed to approach the motor in operation, attach a warning label in a conspicuous position as shown in the figure. Failure to do so may result in a skin burn(s).



Warning label

Precautions for use

This chapter covers limitations and requirements the user should consider when using the product.

Be sure to match the motor output power with the driver output power.

Wiring

- Be sure to use the connection cable exclusively for the electromagnetic brake motor

To connect the motor and driver, always use the dedicated connection cable (sold separately) that the label for electromagnetic brake motor is attached. Limit the number of times so that attaching/detaching between the connection cable and the motor or driver will not exceed 100 times.

Installation circumstances

- Grease measures

On rare occasions, grease may ooze out from the gearhead. If there is concern over possible environmental contamination resulting from the leakage of grease, check for grease stains during regular inspections. Alternatively, install an oil pan or other device to prevent damage resulting from contamination. Grease leakage may lead to problems in the user's equipment or products.

- Caution when using in low temperature environment

When an ambient temperature is low, since the load torque may increase by the oil seal or viscosity increment of grease used in the gearhead, the output torque may decrease or the overload alarm may be generated. However, as time passes, the oil seal or grease is warmed up, and the motor can be driven without generating an overload alarm.

Operations

- Use the electromagnetic brake motor in an application of vertical drive such as elevating equipment

When the motor is used in vertical drive such as elevating equipment (lifting and lowering device), use an electromagnetic brake motor so that the load can be held in position.

- Rotation direction of the gearhead output shaft

In the case of the combination type-parallel shaft gearhead, the rotation direction of the gearhead output shaft may vary with that of the motor output shaft depending on the gear ratio of the gearhead.

Gear ratio	Rotation direction of the gearhead output shaft
5, 10, 15, 20, 200	Same direction as the motor output shaft
30, 50, 100*	Opposite direction to the motor output shaft

* Same direction as the motor output shaft when the gear ratio is 100 for the 200 W type

- Sliding noise of electromagnetic brake

An electromagnetic brake motor may cause a sliding noise of the brake disk during operation. There is no functional problem.

Insulation resistance measurement and dielectric strength test

- Do not conduct the insulation resistance measurement or dielectric strength test with the motor and driver connected

Conducting the insulation resistance measurement or dielectric strength test with the motor and driver connected may result in damage to the product.

Checking the product

This chapter explains the items you should check, as well as the name of each part.

Package contents

Verify that the items listed below are included. Report any missing or damaged items to the branch or sales office from which you purchased the product.

Motor 1 unit

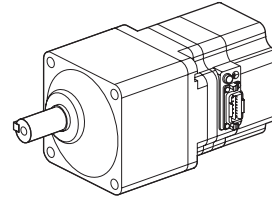

Combination type:
With a gearhead, fixing the parallel key to the output shaft

Mounting screw set..... 1 set

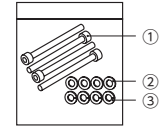

- ① Hexagonal socket head screw: 4 pieces
- ② Plain washer: 4 pieces
- ③ Spring washer: 4 pieces

Included with the combination type.

Instructions and Precautions for Safe Use 1 copy

Model

Verify the model name of the purchased product against the model shown on the package label. Check the motor model and the gearhead model against the model name shown on their nameplates, respectively.

The box (□) in the model name indicates a number representing the gear ratio. The box (◆) in the model name for the round shaft type indicates **A** (no machining) or **AC** (shaft flat).

- Electromagnetic brake motor, combination type-parallel shaft gearhead

Output power	Combination type motor model	Motor model	Gearhead model
30 W	BLM230HPM-□S	BLM230HPM-GFV	GFV2G□S
60 W	BLM460SHPM-□S	BLM460SHPM-GFV	GFV4G□S
120 W	BLM5120HPM-□S	BLM5120HPM-GFV	GFV5G□S
200 W	BLM6200SHPM-□S	BLM6200SHPM-GFV	GFV6G□S

- Electromagnetic brake motor, round shaft type

Output power	Motor model
30 W	BLM230HPM-◆S
60 W	BLM260HPM-◆S
120 W	BLM5120HPM-◆S
200 W	BLM5200HPM-◆S

Information about nameplate

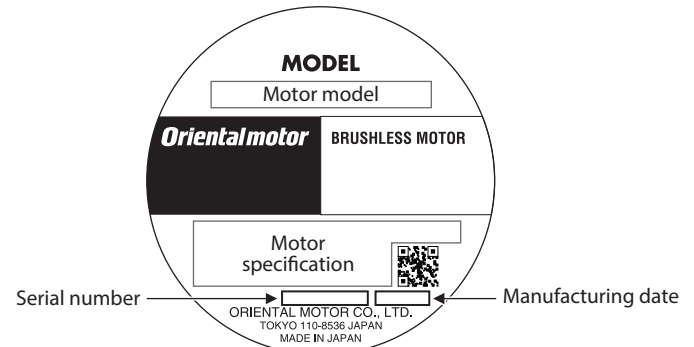

■ Drivers possible to combine

Products with which the motors can be combined are listed below.

● BLE2 Series

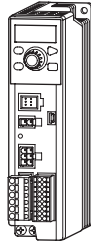

Output power	Motor model	Driver model	
		Single-phase 100-120 VAC	Single-phase 200-240 VAC Three-phase 200-240 VAC
30 W	BLM230	BLE2D30-AM	BLE2D30-CM
60 W	BLM460S BLM260	BLE2D60-AM	BLE2D60-CM
120 W	BLM5120	BLE2D120-AM	BLE2D120-CM
200 W	BLM6200S BLM5200	—	BLE2D200-CM

■ Connection cable (sold separately)

To connect the motor and driver, the dedicated connection cable (sold separately) is required.

The connection cables are provided up to 20 m (65.6 ft.).

Model name and type

CC 005 KHBL M F

Cable length

- 005** : 0.5 m (1.6 ft.)
- 010** : 1 m (3.3 ft.)
- 015** : 1.5 m (4.9 ft.)
- 020** : 2 m (6.6 ft.)
- 025** : 2.5 m (8.2 ft.)
- 030** : 3 m (9.8 ft.)
- 040** : 4 m (13.1 ft.)
- 050** : 5 m (16.4 ft.)
- 070** : 7 m (23.0 ft.)
- 100** : 10 m (32.8 ft.)
- 150** : 15 m (49.2 ft.)
- 200** : 20 m (65.6 ft.)

Cable outlet direction

- F** : Output shaft direction
- B** : Opposite to output shaft direction
- V** : Vertical direction

Electromagnetic brake motor

Output shaft direction:
CC __ **F**

Opposite to output shaft direction: CC __ **B**

Vertical direction:
CC __ **V**

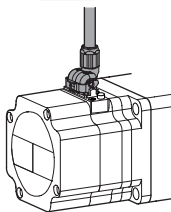
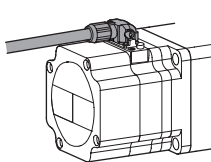
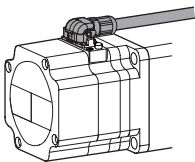

For the round shaft type motor, select the cable outlet direction in consideration of the installation.

■ Names of parts

Motor

The figure shows the 120W type motor.

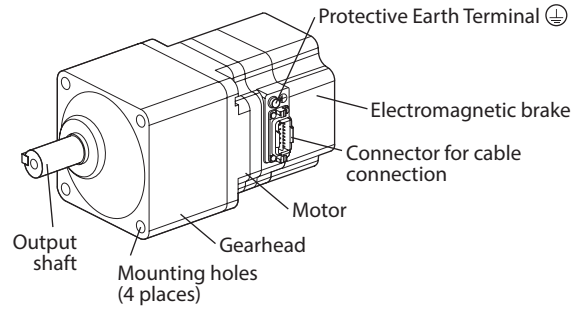

Connection cable (sold separately)

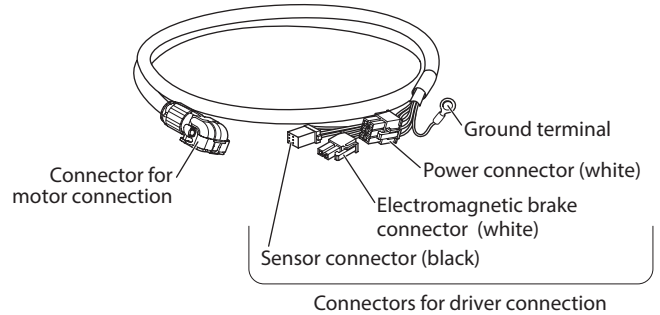

Installation

This section explains the installation method of a load in addition to the installation location and installation method of the product.

■ Installation location

Install the product in a well-ventilated location that provides easy access for inspection. The location must also satisfy the following conditions:

- Indoors
- Operating ambient temperature: 0 to +40 °C (+32 to +104 °F) (non-freezing)
- Operating ambient humidity 85% or less (non-condensing)
- Area that is free of explosive atmosphere or toxic gas (such as sulfuric gas) or liquid
- Area not exposed to direct sun
- Area free of excessive amount of dust, iron particles or the like
- Area free of excessive salt
- Area not subject to continuous vibration or excessive shocks
- Area free of excessive electromagnetic noise (from welders, power machinery, etc.)
- Area free of radioactive materials, magnetic fields or vacuum
- Altitude: Up to 1000 m (3300 ft.) above sea level
- Area not subject to oil (oil droplets) or chemicals
The motor can be used in an environment where it is splashed with water (excluding the part of the connectors for driver connection and the mounting surface of the round shaft type).
However, do not use it under water or in high water pressure.

■ Installation method

● Electromagnetic brake motor, combination type-parallel shaft gearhead

Secure the motor and gearhead through four mounting holes using the included mounting screw set.

Tighten the screws until no gap remains between the product and mounting plate.

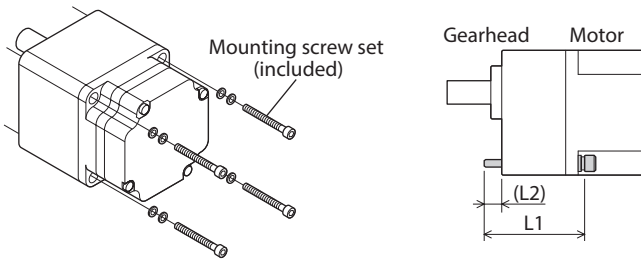

Model	Gear ratio	Hexagonal socket head screw		L2 [mm (in.)]	Tightening torque [N·m (lb-in)]
		Screw size	Material		
BLM230	5 to 20	M4	Stainless steel	50 (1.97)	1.4 (12.3)
	30 to 100			55 (2.17)	
BLM460S	5 to 20	M6		60 (2.36)	5.0 (44)
	30 to 100			65 (2.56)	
BLM5120	5 to 20	M8		70 (2.76)	12.0 (106)
	30 to 100			85 (3.35)	
	200		90 (3.54)		
BLM6200S	5 to 20		85 (3.35)	11 (0.43)	
	30, 50		100 (3.94)		
	100, 200		110 (4.33)		

Removing and assembling the gearhead

See the following steps to replace the gearhead or to change the position of the connector for cable connection.

Removing the gearhead from the motor

Remove the hexagonal socket head screws (M3, 2 places) assembling the motor and gearhead, and detach the gearhead from the motor.

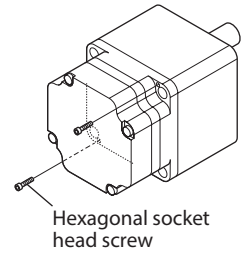

Assembling the gearhead to the motor

1. Keep the pilot sections of the motor and gearhead in parallel, and assemble the gearhead with the motor while slowly rotating it clockwise/counterclockwise. At this time, note so that the pinion of the motor output shaft does not hit the side panel or gears of the gearhead strongly.
2. Check that there is no gap between the motor and gearhead, and tighten them with hexagonal socket head screws (2 places).
Tightening torque: 0.6 N·m (5.3 lb-in)

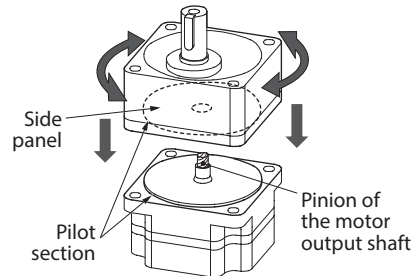

Assemble the gearhead to the motor in a condition where the motor output shaft is in an upward direction.

Note

- Do not forcibly assemble the motor and gearhead. Also, prevent metal objects or foreign substances from entering in the gearhead. The pinion of the motor output shaft or gear may be damaged, resulting in noise or shorter service life.
- Do not allow dust to attach to the pilot sections of the motor and gearhead. Also, assemble the motor and gearhead carefully by not pinching the O-ring at the motor pilot section. If the O-ring is crushed or severed, grease may leak from the gearhead.

● Round shaft type

Secure the motor using the hexagonal socket head screws (not included) through the four mounting holes. Tighten the screws until no gap remains between the product and mounting plate.

Applicable mounting screws

Model	Screw size	Tightening torque [N·m (lb-in)]*
BLM230 BLM260	M4	1.8 [15.9] [1.4 (12.3)]
BLM5120 BLM5200	M8	15.5 [137] [12.0 (106)]

* The brackets [] indicate the value for stainless steel.

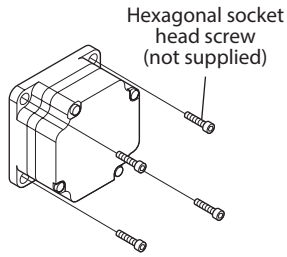

Install the motor to a mounting plate of the following size or larger so that the motor case temperature will not exceed 90 °C (194 °F).

Model	Size of mounting plate [mm (in.)]	Thickness [mm (in.)]	Material
BLM230	115×115 (4.53×4.53)	5 (0.20)	Aluminum alloy
BLM260	135×135 (5.31×5.31)		
BLM5120	165×165 (6.50×6.50)		
BLM5200	200×200 (7.87×7.87)		

Note Do not install the motor to the mounting hole diagonally or assemble the motor forcibly. Doing so may cause damage to the flange pilot section, thereby resulting in damage to the motor.

■ Installing a load

When installing a load on the motor or gearhead, pay attention to the following points.

- Align the centerline of the output shaft with that of the load.
- A key slot is provided on the output shaft of each combination type-parallel shaft gearhead. Form a key slot on the load side and secure the load using the parallel key.

- Note**
- When coupling with a load, pay attention to centering, belt tension, parallelism of pulleys, etc. Also, firmly secure the tightening screws of the coupling or pulleys.
 - When installing a load, do not damage the output shaft or bearing. Forcing in the load by driving it with a hammer, etc., may break the bearing. Do not apply any excessive force to the output shaft.
 - Do not modify or machine the output shaft. This may damage the bearing, resulting in damage to the motor or gearhead.

When using the output shaft end tapped hole of a gearhead (GFV4G, GFV5G, GFV6G only)

Use a tapped hole provided at the end of the output shaft as an auxiliary means for preventing the transfer mechanism from disengaging.

Gearhead model	Screw size	Effective depth of screw
GFV4G□S	M5	10 mm (0.39 in.)
GFV5G□S GFV6G□S	M6	12 mm (0.47 in.)

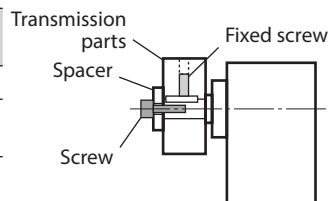

■ Permissible radial load and permissible axial load

Make sure a radial load and axial load applied to the output shaft of the motor and gearhead will not exceed the permissible values shown in the table below.

Note Failure due to fatigue may occur when the motor or gearhead bearings and output shaft are subject to repeated loading by a radial or axial load that is in excess of the permissible limit.

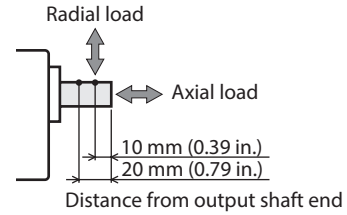

● Electromagnetic brake motor, combination type-parallel shaft gearhead

Model	Gear ratio	Permissible radial load [N (lb.)] * Distance from output shaft end of the gearhead		Permissible axial load [N (lb.)]
		10 mm (0.39 in.)	20 mm (0.79 in.)	
BLM230	5	100 (22) [90 (20)]	150 (33) [110 (24)]	4.0 (9.0)
	10 to 20	150 (33) [130 (29)]	200 (45) [170 (38)]	
	30 to 100	200 (45) [180 (40)]	300 (67) [230 (51)]	
BLM460S	5	200 (45) [180 (40)]	250 (56) [220 (49)]	100 (22)
	10 to 20	300 (67) [270 (60)]	350 (78) [330 (74)]	
	30 to 100	450 (101) [420 (94)]	550 (123) [500 (112)]	
BLM5120	5	300 (67) [230 (51)]	400 (90) [300 (67)]	150 (33)
	10 to 20	400 (90) [370 (83)]	500 (112) [430 (96)]	
	30 to 200	500 (112) [450 (101)]	650 (146) [550 (123)]	
BLM6200S	5 to 20	550 (123) [500 (112)]	800 (180) [700 (157)]	200 (45)
	30, 50	1000 (220) [900 (200)]	1250 (280) [1100 (240)]	
	100, 200	1400 (310) [1200 (270)]	1700 (380) [1400 (310)]	

* The values assume a rated speed of 3000 r/min or below. The values in parentheses [] are based on a speed of 4000 r/min.

● Round shaft type

Model	Permissible radial load [N (lb.)] Distance from output shaft end of the motor		Permissible axial load [N (lb.)]
	10 mm (0.39 in.)	20 mm (0.79 in.)	
BLM230 BLM260	80 (18)	100 (22)	20 (4.5)
BLM5120 BLM5200	150 (33)	170 (38)	25 (5.6)

Connection

■ Connecting the motor and driver

Connect the motor and driver using the connection cable (sold separately). There are three types of connection cables which cable outlet directions are different.

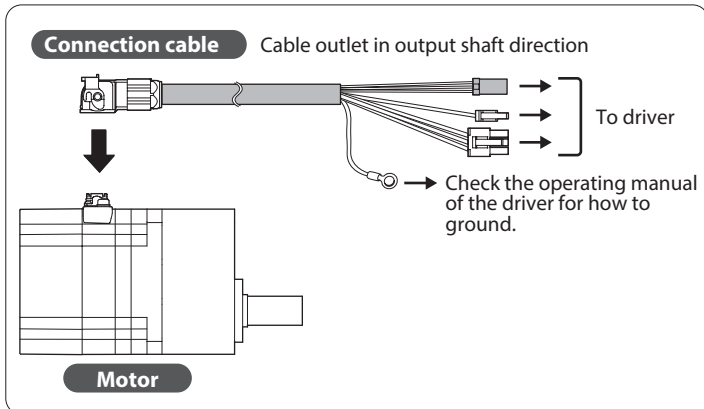

[Cable outlet direction]

Cable outlet in output shaft direction

CC__F

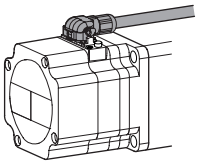

Cable outlet opposite to output shaft direction

CC__B

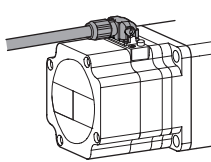

Cable outlet in vertical direction

CC__V

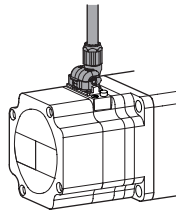

Note

Use the connection cable that the label for electromagnetic brake motor is attached. Failure to do so may result in damage to equipment.

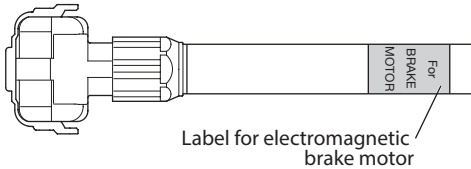

Label for electromagnetic brake motor

■ Connection procedures of the motor and connection cable

The following example explains using the connection cable of "cable outlet in output shaft direction."

1 Remove

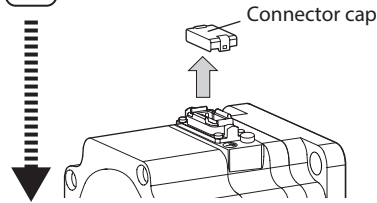

2 Attach

Check the cable outlet direction and insert the connector securely.

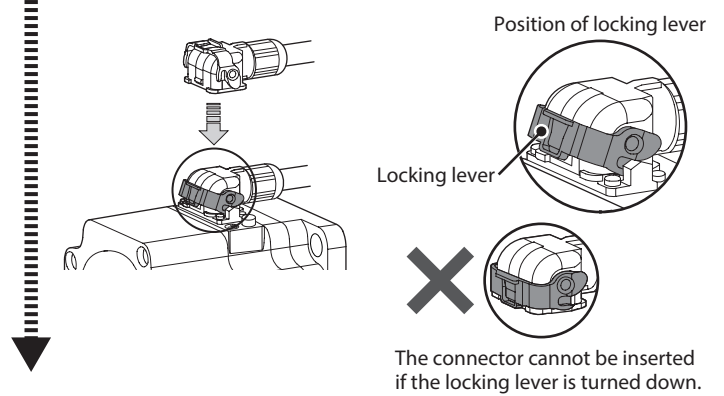

3 Secure

Secure the cable with the locking lever so that the cable does not come off.

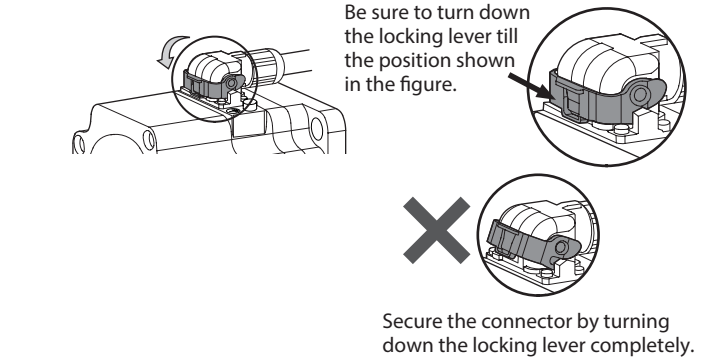

Note

Do not lift up the product by holding the connection cable. Doing so may cause damage to the product.

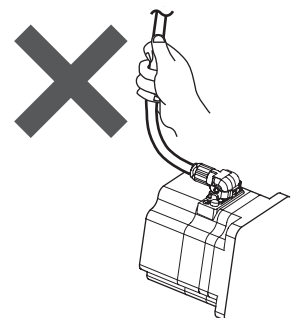

■ Detaching the connection cable

If the locking lever is turned up, the cable can be detached.

Up to two pieces of the connection cables for relay can be connected. Check the operating manual of the driver.

Grounding

Ground using the Protective Earth Terminals ⊕ of the motor and driver, and the ground terminal of the connection cable. Check the operating manual of the driver for how to ground.

Note Be sure to ground the motor and driver. Failure to do so may result in electric shock or damage to the product. Static electricity may cause damage to the product if the Protective Earth Terminals are not grounded.

Inspection and maintenance

■ Inspection

It is recommended that periodic inspections would be conducted for the items listed below after each operation of the motor. If an abnormal condition is noted, discontinue any use and contact your nearest Oriental Motor sales office.

Note Do not conduct the insulation resistance measurement or dielectric strength test with the motor and driver connected. Conducting the insulation resistance measurement or dielectric strength test with the motor and driver connected may result in damage to the product.

● Inspection item

- Check if any of the mounting screws of the motor and gearhead is loose.
- Check if the bearing part (ball bearings) of the motor generates unusual noises.
- Check if the bearing part (ball bearings) or gear meshing part of the gearhead generates unusual noises.
- Check if the output shaft of the motor and gearhead and a load shaft are out of alignment.
- Check if a damage or stress is applied on the cable or the connection part between the cable and driver is loose.

■ Warranty

Check on the Oriental Motor Website for the product warranty.

■ Disposal

Dispose the product correctly in accordance with laws and regulations, or instructions of local governments.

Peripheral equipment (sold separately)

Peripheral equipment such as couplings and mounting brackets can be checked on the Oriental Motor Website.

About the mounting bracket (SOL) of the motor

Secure the motor and mounting bracket so that the connector for motor connection is positioned other than the installation surface side of the mounting bracket. Installation in a state where the motor connector is positioned on the installation surface side is not recommended since the motor connector is come into contact with the mounting bracket or installation surface.

Specifications

Check on the Oriental Motor Website for the product specifications.

General specifications

Operating environment	Ambient temperature	0 to +40 °C (+32 to +104 °F) (non-freezing)
	Ambient humidity	85% or less (non-condensing)
	Altitude	Up to 1000 m (3300 ft.) above sea level
	Surrounding atmosphere	No corrosive gas, dust. Cannot be used in radioactive materials, magnetic field, vacuum or other special environment (For details about installation locations, refer to p.4 "Installation location")
Vibration		Not subject to continuous vibrations or excessive impact.
		In conformance with JIS C 60068-2-6 "Sine-wave vibration test method" Frequency range: 10 to 55 Hz, Pulsating amplitude: 0.15 mm Sweep direction: 3 directions (X, Y, Z), Number of sweeps: 20 times
Storage environment Shipping environment	Ambient temperature	-20 to +70 °C (-4 to +158 °F) (non-freezing)
	Ambient humidity	85% or less (non-condensing)
	Altitude	Up to 3000 m (10000 ft.) above sea level
Surrounding atmosphere		No corrosive gas, dust, water or oil. Cannot be used in radioactive materials, magnetic field, vacuum or other special environment
	Degree of protection	IP66 (When the connection cable is installed to the motor. Excluding the mounting surface of the round shaft type and the part of the connectors for driver connection.)

Regulations and standards

■ UL Standards and CSA Standards

This product is recognized by UL under the UL and CSA Standards.

■ CE Marking

This product is affixed with the marks under the following directives.

● Low Voltage Directive

Installation conditions

Overvoltage category: II, Pollution degree: 3,
Protection against electric shock: Class I equipment

- This product cannot be used in IT power distribution systems.
- Isolate the connection cable, power supply cable and other drive cables from the signal cables by means of double insulation.

■ RoHS Directive

This product does not contain the substances exceeding the restriction values.

- Unauthorized reproduction or copying of all or part of this manual is prohibited.
- Oriental Motor shall not be liable whatsoever for any problems relating to industrial property rights arising from use of any information, circuit, equipment or device provided or referenced in this manual.
- Characteristics, specifications and dimensions are subject to change without notice.
- While we make every effort to offer accurate information in the manual, we welcome your input. Should you find unclear descriptions, errors or omissions, please contact the nearest office.
- **Orientalmotor** is a registered trademark or trademark of Oriental Motor Co., Ltd., in Japan and other countries.

© Copyright ORIENTAL MOTOR CO., LTD. 2020

Published in February 2022

- Please contact your nearest Oriental Motor office for further information.

ORIENTAL MOTOR U.S.A. CORP.
 Technical Support Tel:800-468-3982
 8:30am EST to 5:00pm PST (M-F)
www.orientalmotor.com

ORIENTAL MOTOR (EUROPA) GmbH
 Schiessstraße 44, 40549 Düsseldorf, Germany
 Technical Support Tel:00 800/22 55 66 22
www.orientalmotor.de

ORIENTAL MOTOR (UK) LTD.
 Unit 5 Faraday Office Park, Rankine Road,
 Basingstoke, Hampshire RG24 8QB UK
 Tel:+44-1256347090
www.oriental-motor.co.uk

ORIENTAL MOTOR (FRANCE) SARL
 Tel:+33-1 47 86 97 50
www.orientalmotor.fr

ORIENTAL MOTOR ITALIA s.r.l.
 Tel:+39-02-93906347
www.orientalmotor.it

ORIENTAL MOTOR CO., LTD.
 4-8-1Higashiueno,Taito-ku,Tokyo 110-8536
 Japan
 Tel:+81-3-6744-0361
www.orientalmotor.co.jp

ORIENTAL MOTOR ASIA PACIFIC PTE. LTD.
 Singapore
 Tel:1800-842-0280
www.orientalmotor.com.sg

ORIENTAL MOTOR (MALAYSIA) SDN. BHD.
 Tel:1800-806-161
www.orientalmotor.com.my

ORIENTAL MOTOR (THAILAND) CO., LTD.
 Tel:1800-888-881
www.orientalmotor.co.th

ORIENTAL MOTOR (INDIA) PVT. LTD.
 Tel:1800-120-1995 (For English)
 1800-121-4149 (For Hindi)
www.orientalmotor.co.in

TAIWAN ORIENTAL MOTOR CO., LTD.
 Tel:0800-060708
www.orientalmotor.com.tw

SHANGHAI ORIENTAL MOTOR CO., LTD.
 Tel:400-820-6516
www.orientalmotor.com.cn

INA ORIENTAL MOTOR CO., LTD.
 Korea
 Tel:080-777-2042
www.inaom.co.kr