

OPERATING MANUAL

Brushless Motor

BLM Motor Connector Type Hollow shaft flat gearhead

Introduction

■ Before using the product

Only qualified personnel of electrical and mechanical engineering should work with the product. Use the product correctly after thoroughly reading the section "Safety precautions." In addition, be sure to observe the contents described in warning, caution, and note in this manual. The product described in this manual has been designed and manufactured to be incorporated in general industrial equipment. Do not use for any other purpose. Oriental Motor Co., Ltd. is not responsible for any damage caused through failure to observe this warning.

■ Related operating manuals



Operating manuals for this product are listed below. Operating manuals are not included with the product. Download from Oriental Motor Website Download Page or contact your nearest Oriental Motor sales office.

	Operating manual name
Motor	BLM Motor Connector Type Hollow shaft flat gearhead OPERATING MANUAL (this document)
Driver	BMU Series OPERATING MANUAL BLE2 Series OPERATING MANUAL

Refer to the operating manuals of the driver for details about connections and operations. The electromagnetic brake motors can be combined only with drivers of the **BLE2** Series.

Safety precautions



The precautions described below are intended to ensure the safe and correct use of the product, and to prevent the customer and others from exposure to the risk of injury. Use the product only after carefully reading and fully understanding these instructions.

 WARNING	Handling the product without observing the instructions that accompany a "WARNING" symbol may result in serious injury or death.
 CAUTION	Handling the product without observing the instructions that accompany a "CAUTION" symbol may result in injury or property damage.
 Note	The items under this heading contain important handling instructions that the user should observe to ensure safe use of the product.

[Description of graphic symbols]

 : Indicates "prohibited" actions that must not be performed.



 : Indicates "compulsory" actions that must be performed.

 WARNING	
	<ul style="list-style-type: none"> Do not use the product in explosive or corrosive environments, in the presence of flammable gases or near combustibles. Doing so may result in fire, electric shock or injury. Do not transport, install the product, perform connections or inspections when the power is on. Always turn the power off before carrying out these operations. Failure to do so may result in electric shock or equipment damage. Use an electromagnetic brake motor in an application of vertical drive such as elevating equipment. If a power failure occurs or the driver protective function is activated in a state where the motor without an electromagnetic brake is used, the moving part may fall when the motor stops. This may cause injury or damage to equipment. When using the electromagnetic brake motor in an application of vertical drive (elevating application), be sure check the load condition sufficiently before operating. If a load in excess of the rated torque is applied or the small torque limiting value is set, the load may fall. This may cause injury or damage to equipment.



Thank you for purchasing an Oriental Motor product. This Operating Manual describes product handling procedures and safety precautions.

- Please read it thoroughly to ensure safe operation.
- Always keep the manual where it is readily available.

WARNING

	<ul style="list-style-type: none"> Do not machine or modify the connection cable. Doing so may result in fire, electric shock or damage to equipment. Do not apply any excessive force to the motor connector. Doing so may result in fire, electric shock or damage to equipment. Do not forcibly bend, pull or pinch the cables. Doing so may result in fire, electric shock or damage to equipment. Do not remove the connector cap until the connection cable is connected so that the O-ring of the connector for cable connection on the motor is not damaged. Doing so may result in fire, electrical shock, or damage to equipment. Do not touch the motor or driver when conducting insulation resistance measurement or dielectric strength test. Accidental contact may result in electric shock. Do not disassemble or modify the motor and gearhead. Doing so may result in electric shock, injury or damage to equipment. Refer all such internal inspections and repairs to the branch or sales office from which you purchased the product.
	<ul style="list-style-type: none"> Only qualified and educated personnel should be allowed to perform installation, connection, operation and inspection/ troubleshooting of the product. Handling by unqualified and uneducated personnel may result in fire, electric shock, injury or equipment damage. The motor is Class I equipment. When installing the motor and driver, ground their Protective Earth Terminals. Failure to do so may result in electric shock. Use a motor and driver only in the specified combination. An incorrect combination may result in fire, electric shock or damage to equipment. Always turn off the power before performing maintenance/ inspection. Failure to do so may result in electric shock

CAUTION

	<ul style="list-style-type: none"> Do not use the motor beyond the specifications. Doing so may result in fire, electric shock, injury or damage to equipment. Do not touch the motor while operating or immediately after stopping. The surfaces of the motor is hot, and it may cause a skin burn(s). Do not leave anything around the motor that would obstruct ventilation. Doing so may result in damage to equipment. Do not lift up the product by holding the connection cable. Doing so may result in injury. Do not touch the motor output shaft end with bare hands. Doing so may cause injury. When assembling the motor with the gearhead, exercise caution not to pinch your fingers or other parts of your body between the motor and gearhead. Injury may result. When installing the motor in equipment, exercise caution not to pinch your fingers or other parts of your body between the product and equipment. Injury may result. Do not touch the rotating part (output shaft) when operating the motor. Doing so may result in injury.
	<ul style="list-style-type: none"> Securely install the motor to the mounting plate. Inappropriate installation may cause the motor and gearhead to detach and fall, resulting in injury or equipment damage. Provide a cover over the rotating part (output shaft). Failure to do so may cause injury. Securely install a load on the output shaft. Failure to do so may cause injury. Be sure to ground the motor and driver to prevent them from being damaged by static electricity. Failure to do so may result in fire or damage to equipment. The motor surface temperature may exceed 70 °C (158 °F) even under normal operating conditions. If the operator is allowed to approach the motor in operation, attach a warning label in a conspicuous position as shown in the figure. Failure to do so may result in a skin burn(s).



Precautions for use

This chapter covers limitations and requirements the user should consider when using the product.

Be sure to match the motor output power with the driver output power.

Wiring

● Connecting the motor and driver

To connect the motor and driver, always use the dedicated connection cable (sold separately). With electromagnetic brake motors, use the dedicated connection cable (sold separately) that a label for electromagnetic brake motor is attached. Limit the number of times so that attaching/detaching between the connection cable and the motor or driver will not exceed 100 times.

● Connection cable

Do not apply a strong force on the locking lever of the connector for motor connection. Applying a strong force on the locking lever may cause damage. Refer to p.7 for details.

Installation circumstances

● Grease measures

On rare occasions, grease may ooze out from the gearhead. If there is concern over possible environmental contamination resulting from the leakage of grease, check for grease stains during regular inspections. Alternatively, install an oil pan or other device to prevent damage resulting from contamination. Grease leakage may lead to problems in the user's equipment or products.

● Note when using in low temperature environment

When an ambient temperature is low, since the load torque may increase by the oil seal or viscosity increment of grease used in the gearhead, the output torque may decrease or the overload alarm may be generated. However, as time passes, the oil seal or grease is warmed up, and the motor can be driven without generating an overload alarm.

● Apply grease to the hollow output shaft of a hollow shaft flat gearhead

Apply grease (molybdenum disulfide grease, etc.) on the surface of the loadshaft and inner walls of the hollow output shaft to prevent seizure.

Insulation resistance measurement and dielectric strength test

● Do not conduct the insulation resistance measurement or dielectric strength test with the motor and driver connected

Conducting the insulation resistance measurement or dielectric strength test with the motor and driver connected may result in damage to the product.

Operations

● Use the electromagnetic brake motor in an application of vertical drive such as elevating equipment

When the motor is used in vertical drive such as elevating equipment (lifting and lowering device), use an electromagnetic brake motor so that the load can be held in position.

● Rotation direction of the gearhead output shaft

The rotation directions of the gearhead output shaft relative to the motor output shaft are as shown in the figures below.

Check the operating manual of the driver for the rotation direction of the gearhead output shaft relative to the operation input signals of the driver.

Motor output shaft	Gearhead output shaft	
	Viewed from Front	Viewed from Rear

● Sliding noise of electromagnetic brake

An electromagnetic brake motor may cause a sliding noise of the brake disk during operation. There is no functional problem.

Applicable motors for GFS6G□FR

Motors manufactured before June 2020 cannot be assembled with GFS6G□FR. When replacing the motor, check the manufacturing date described on the motor nameplate before use.

Checking the product

This chapter explains the items you should check, as well as the name of each part.

■ Package contents

Verify that the items listed below are included.

Report any missing or damaged items to the branch or sales office from which you purchased the product.

□ Motor.....1 unit

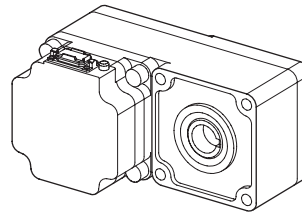

□ Mounting screw parallel key 1 set

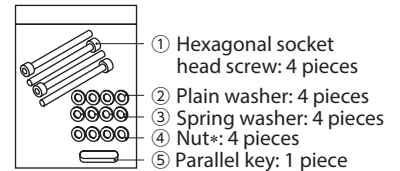

* For the 200 W, 300 W and 400 W types, nuts are not included.

□ Safety cover 1 set

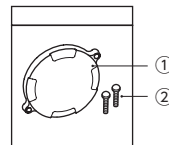

① Safety cover: 1 piece
② Mounting screw: 2 pieces

□ Instructions and Precautions for Safe Use 1 set

■ How to identify the product model

BLM 6 200 S H P M - 5 FR
① ② ③ ④ ⑤ ⑥ ⑦ ⑧ ⑨

① Motor type	BLM: Brushless Motor
② Frame size	2: 60 mm (2.36 in.) 4: 80 mm (3.15 in.) 5: 90 mm (3.54 in.) 6: 104 mm (4.09 in.)
③ Output power	30: 30 W 60: 60 W 120: 120 W 200: 200 W 300: 300 W 400: 400 W
④ Motor classification	S
⑤ Motor connection method	H: Connector type
⑥ Degree of protection	P: IP65 (Motor: IP66 specification)
⑦ Additional function	M: Electromagnetic brake type
⑧ Gear ratio	Number: Gear ratio of gearhead
⑨ Gearhead type	FR: Hollow shaft flat gearhead FR Gear

Model

Verify the model name of the purchased product against the model shown on the package label. Check the motor model and the gearhead model against the model name shown on their nameplates, respectively. Tell us the model name, product serial number, and manufacturing date when you contact us. The box (□) in the model name indicates a number representing the gear ratio.

Combination type

Output power	Model	Motor model	Gearhead model	
			Model	Gear ratio
30 W	BLM230HP-□FR	BLM230HP-GFV	GFS2G□FR	5 to 200
60 W	BLM460SHP-□FR	BLM460SHP-GFV	GFS4G□FR	5 to 200
120 W	BLM5120HP-□FR	BLM5120HP-GFV	GFS5G□FR	5 to 200
200 W	BLM6200SHP-□FR	BLM6200SHP-GFV	GFS6G□FR	10 to 100
300 W	BLM6300SHP-□FR	BLM6300SHP-GFV		10 to 100
400 W	BLM6400SHP-□FR	BLM6400SHP-GFV		5 to 100

Combination type with electromagnetic brake

Output power	Model	Motor model	Gearhead model	
			Model	Gear ratio
30 W	BLM230HPM-□FR	BLM230HPM-GFV	GFS2G□FR	5 to 200
60 W	BLM460SHPM-□FR	BLM460SHPM-GFV	GFS4G□FR	5 to 200
120 W	BLM5120HPM-□FR	BLM5120HPM-GFV	GFS5G□FR	5 to 200
200 W	BLM6200SHPM-□FR	BLM6200SHPM-GFV	GFS6G□FR	10 to 100

Information about nameplate

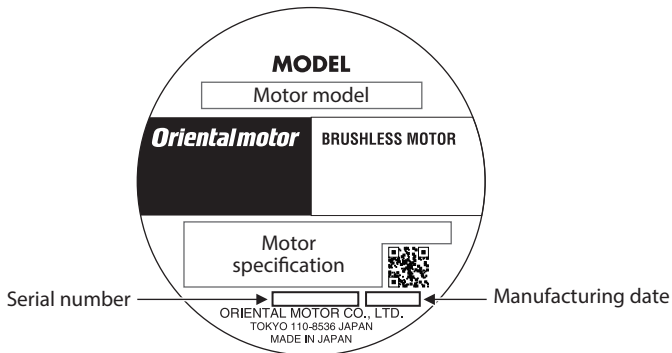

Drivers possible to combine

Products with which the motors can be combined are listed below.

Series name	Output power	Power supply voltage	Driver name
BMU series	30 W	Single-phase 100-120 V	BMUD30-A2
		Single-phase, Three-phase 200-240 V	BMUD30-C2
	60 W	Single-phase 100-120 V	BMUD60-A2
		Single-phase, Three-phase 200-240 V	BMUD60-C2
	120 W	Single-phase 100-120 V	BMUD120-A2
		Single-phase, Three-phase 200-240 V	BMUD120-C2
	200 W	Single-phase 100-120 V	BMUD200-A
		Single-phase, Three-phase 200-240 V	BMUD200-C
	300 W	Single-phase, Three-phase 200-240 V	BMUD300-C
	400 W	Three-phase 200-240 V	BMUD400-S
BLE2 series	30 W	Single-phase 100-120 V	BLE2D30-A
		Single-phase, Three-phase 200-240 V	BLE2D30-C
	60 W	Single-phase 100-120 V	BLE2D60-A
		Single-phase, Three-phase 200-240 V	BLE2D60-C
	120 W	Single-phase 100-120 V	BLE2D120-A
		Single-phase, Three-phase 200-240 V	BLE2D120-C
	200 W	Single-phase, Three-phase 200-240 V	BLE2D200-C
	300 W	Single-phase, Three-phase 200-240 V	BLE2D300-C
	400 W	Three-phase 200-240 V	BLE2D400-S
	BLE2 series (electromagnetic brake)	30 W	Single-phase 100-120 V
Single-phase, Three-phase 200-240 V			BLE2D30-CM
60 W		Single-phase 100-120 V	BLE2D60-AM
		Single-phase, Three-phase 200-240 V	BLE2D60-CM
120 W		Single-phase 100-120 V	BLE2D120-AM
		Single-phase, Three-phase 200-240 V	BLE2D120-CM
200 W	Single-phase, Three-phase 200-240 V	BLE2D200-CM	

BMU series



BLE2 series

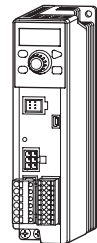

■ Connection cable (sold separately)

To connect the motor and driver, the dedicated connection cable (sold separately) is required.
The connection cables are provided up to 20 m (65.6 ft.). The cable length that can be connected vary depending on the driver used. Check the operating manual of the driver.

Model name and type

CC 005 □ **HBL** **M** **F**

Cable length

005 : 0.5 m (1.6 ft.)
010 : 1 m (3.3 ft.)
015 : 1.5 m (4.9 ft.)
020 : 2 m (6.6 ft.)
025 : 2.5 m (8.2 ft.)
030 : 3 m (9.8 ft.)
040 : 4 m (13.1 ft.)
050 : 5 m (16.4 ft.)
070 : 7 m (23.0 ft.)
100 : 10 m (32.8 ft.)
150 : 15 m (49.2 ft.)
200 : 20 m (65.6 ft.)

M : Electromagnetic brake type
Blank : Combination type

□ : Cable classification

Cable outlet direction

F : Output shaft direction
B : Opposite to output shaft direction
V : Vertical direction

Output shaft direction:
CC ___ **F**

Opposite to output shaft direction:
CC ___ **B**

Vertical direction:
CC ___ **V**

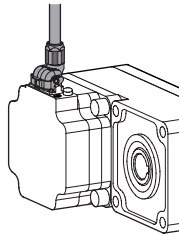
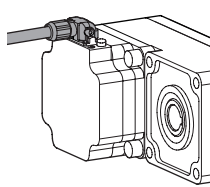
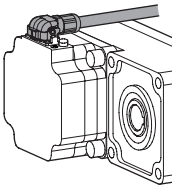

■ Names of parts

Motor

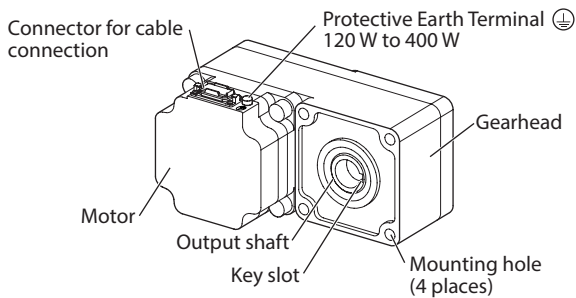

Connection cable (sold separately)

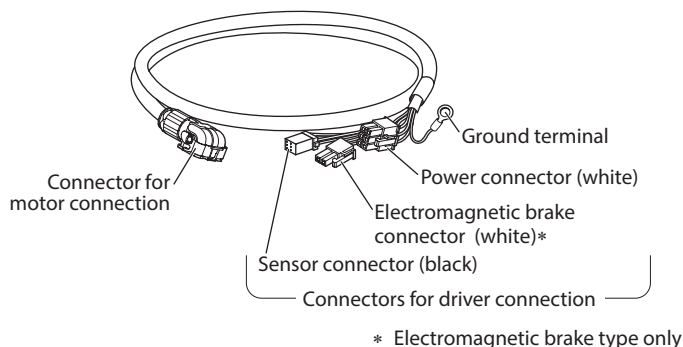

Installation

This section explains the installation method of a load in addition to the installation location and installation method of the product.

■ Installation location

Install the product in a well-ventilated location that provides easy access for inspection. The location must also satisfy the following conditions:

- Indoors
 - Operating ambient temperature: 0 to +40 °C (+32 to +104 °F) (non-freezing)
 - Operating ambient humidity: 85% or less (non-condensing)
 - Area that is free of explosive atmosphere or toxic gas (such as sulfuric gas) or liquid
 - Area not exposed to direct sun
 - Area free of excessive amount of dust, iron particles or the like
 - Area free of excessive salt
 - Area not subject to continuous vibration or excessive shocks
 - Area free of excessive electromagnetic noise (from welders, power machinery, etc.)
 - Area free of radioactive materials, magnetic fields or vacuum
 - Altitude Up to 1000 m (3300 ft.) above sea level
 - Area not subject to oil (oil droplets) or chemicals
- The motor can be used in an environment where it is splashed with water (excluding the part of the connectors for driver connection). However, do not use it under water or in high water pressure.

■ Installation method

A hollow shaft flat gearhead can be installed by using either its front or rear side as the mounting surface. Secure with the included hexagonal socket head screws through the four mounting holes so as not to leave a gap between the motor and mounting plate. Also, attach the included safety cover to the hollow output shaft on the end opposite from the one where the load shaft is installed.

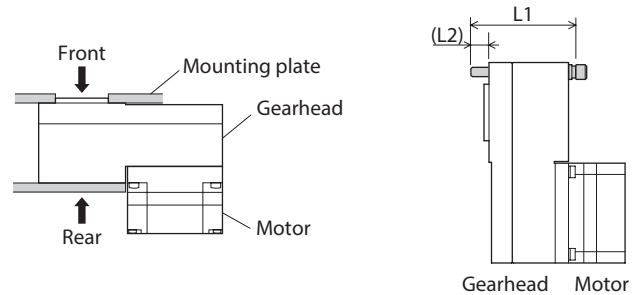

Mounting screw (included)

Output power	Hexagonal socket head screw		L2 [mm (in.)]	Tightening torque [N·m (lb-in)]
	Screw size	L1 [mm (in.)]		
30 W	M5	65 (2.56)	15(0.59)	3.8 (33)
60 W	M6	70 (2.76)	14(0.55)	6.4 (56)
120 W	M8	90 (3.54)	21(0.83)	15.5 (137)
200 W		100 (3.94)	13 (0.51)	
300 W				
400 W				

● Using the front side as the mounting surface

When the gearhead is installed by using its front side as the mounting surface, use the boss section of the output shaft to align the center.

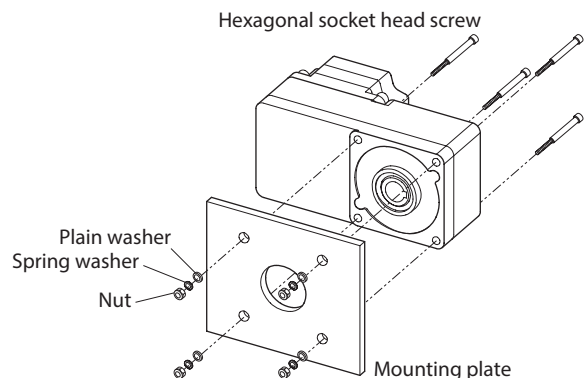

● Using the rear side as the mounting surface

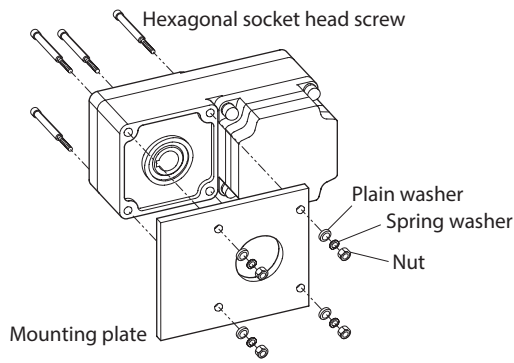

● Installing the safety cover

After installing a load, attach the included safety cover. The safety cover can be attached to either face. Tightening torque: 0.45 N·m (3.9 lb-in)

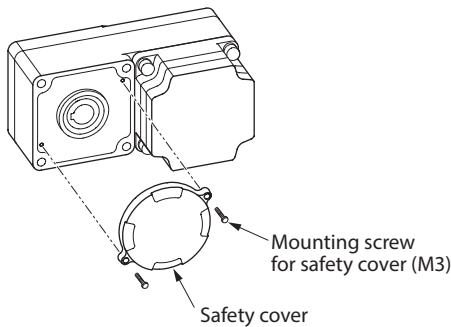

Removing and assembling the gearhead

See the following steps to replace the gearhead or to change the position of the connector for cable connection. However, when the connection cable which cable outlet direction is the output shaft side (model: CC__F) is used, the motor cannot be installed in the direction that the cable faces the hollow output shaft side.

Removing the gearhead from the motor

Remove the hexagonal socket head screws (4 places) assembling the motor and gearhead, and detach the gearhead from the motor.

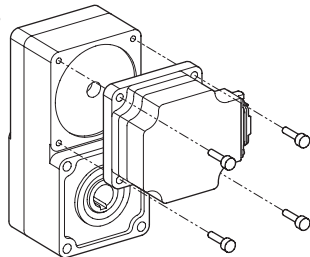

Assembling the gearhead to the motor

1. Keep the pilot sections of the motor and gearhead in parallel, and assemble the gearhead with the motor while slowly rotating it clockwise/counterclockwise. At this time, note so that the pinion of the motor output shaft does not hit the side panel or gears of the gearhead strongly.

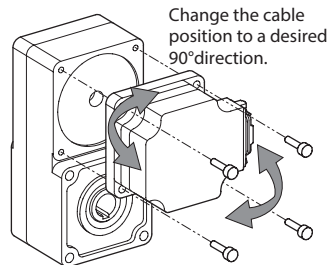

2. Check that there is no gap between the motor and gearhead, and tighten them with hexagonal socket head screws (4 places).

Output power	Screw size	Tightening torque [N·m (lb-in)]
30 W	M4	1.8 (15.9)
60 W	M6	6.4 (56)
120 W 200 W 300 W 400 W	M8	15.5 (137)

Note

- Do not forcibly assemble the motor and gearhead. Also, prevent metal objects or foreign substances from entering in the gearhead. The pinion of the motor output shaft or gear may be damaged, resulting in noise or shorter service life.
- Do not allow dust to attach to the pilot sections of the motor and gearhead. Also, assemble the motor and gearhead carefully by not pinching the O-ring at the motor pilot section. If the O-ring is crushed or severed, grease may leak from the gearhead.

■ Installing a load

If a large impact occurs at instantaneous stop or a large radial load is applied, secure a stepped load shaft.

Note

- Apply grease (molybdenum disulfide grease, etc.) on the surface of the load shaft and inner walls of the hollow output shaft to prevent seizure.
- When installing a load, do not damage the output shaft or bearing. Forcibly inserting the load by driving it with a hammer may damage the bearing. Do not apply any excessive force to the output shaft.
- Do not modify or machine the output shaft. This may damage the bearing, resulting in damage to the motor and gearhead.

● Stepped load shaft

Secure the retaining ring to the load shaft by tightening the hexagonal socket head screw over a spacer, plain washer and spring washer.

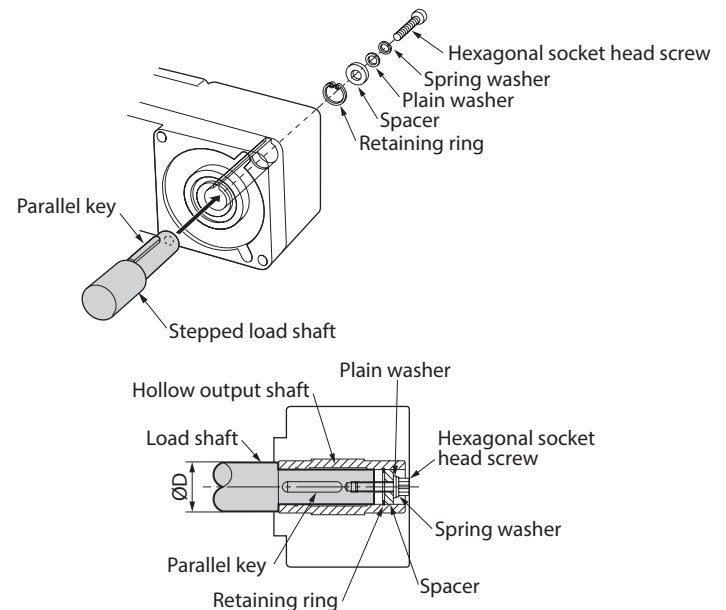

● Non-stepped load shaft

Install a spacer on the load shaft side and secure the retaining ring to the load shaft by tightening the hexagonal socket head screw over a spacer, flat washer and spring washer.

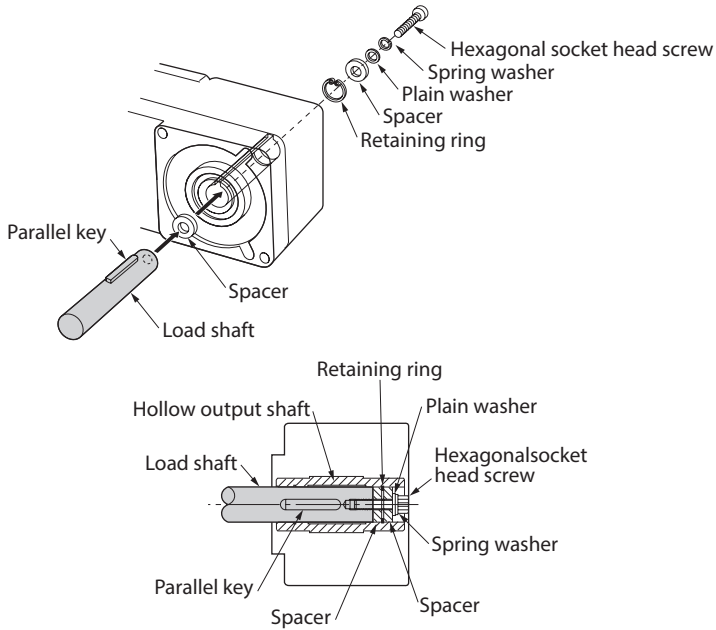

Recommended load shaft installation dimensions [Unit: mm (in.)]

Output power	Inner diameter of hollow shaft (H8)	Recommended diameter of load shaft (h7)	Nominal diameter of retaining ring
30 W	$\varnothing 12^{+0.027}_0$ ($\varnothing 0.4724^{+0.0011}$)	$\varnothing 12^0_{-0.018}$ ($\varnothing 0.4724^0_{-0.0007}$)	$\varnothing 12$ ($\varnothing 0.47$)
60 W	$\varnothing 15^{+0.027}_0$ ($\varnothing 0.5906^{+0.0011}$)	$\varnothing 15^0_{-0.018}$ ($\varnothing 0.5906^0_{-0.0007}$)	$\varnothing 15$ ($\varnothing 0.59$)
120 W	$\varnothing 20^{+0.033}_0$ ($\varnothing 0.7874^{+0.0013}$)	$\varnothing 20^0_{-0.021}$ ($\varnothing 0.7874^0_{-0.0008}$)	$\varnothing 20$ ($\varnothing 0.79$)
200 W 300 W 400 W	$\varnothing 25^{+0.033}_0$ ($\varnothing 0.9843^{+0.0013}$)	$\varnothing 25^0_{-0.021}$ ($\varnothing 0.9843^0_{-0.0008}$)	$\varnothing 25$ ($\varnothing 0.98$)

Output power	Applicable screw	Spacer thickness	Outer diameter of stepped shaft (ØD)
30 W	M4	3 (0.12)	20 (0.79)
60 W	M5	4 (0.16)	25 (0.98)
120 W	M6	5 (0.20)	30 (1.18)
200 W 300 W 400 W	M8	6 (0.24) [3 (0.12)]*	40 (1.57)

* The value in the brackets [] assumes when using the rear side as the mounting surface.

■ Permissible radial load and permissible axial load

Make sure a radial load and axial load applied to the output shaft will not exceed the permissible values shown in the table below.

Note Failure due to fatigue may occur when the bearings and output shaft are subject to repeated loading by a radial or axial load that is in excess of the permissible limit.

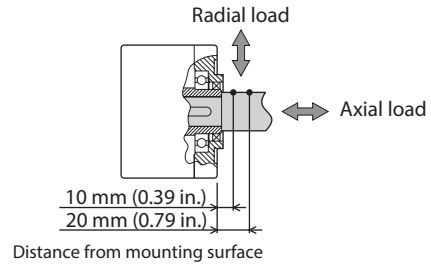

Output power	Gear ratio	Permissible radial load [N (lb.)]*1 Distance from gearhead mounting surface		Permissible axial load [N (lb.)]
		10 mm (0.39 in.)	20 mm (0.79 in.)	
30 W	5, 10	450 (101) [410 (92)]	370 (83) [330 (74)]	200 (45)
	15 to 200	500 (112) [460 (103)]	400 (90) [370 (83)]	
60 W	5, 10	800 (180) [730 (164)]	660 (148) [600 (135)]	400 (90)
	15 to 200	1200 (270) [1100 (240)]	1000 (220) [910 (200)]	
120 W	5, 10	900 (200) [820 (184)]	770 (173) [700 (157)]	500 (112)
	15, 20	1300 (290) [1200 (270)]	1110 (240) [1020 (220)]	
200 W 300 W 400 W	5*2, 10	1230 (270) [1130 (250)]	1070 (240) [990 (220)]	800 (180)
	15, 20	1680 (370) [1550 (340)]	1470 (330) [1360 (300)]	
	30 to 100	2040 (450) [1900 (420)]	1780 (400) [1660 (370)]	

*1 The values assume a rated speed of 3000 r/min or below.

The values in brackets [] are based on a speed of 4000 r/min.

*2 400 W Only

Connection

■ Connecting the motor and driver

Connect the motor and driver using the connection cable (sold separately). There are three types of connection cables which cable outlet directions are different.

The figure shows the electromagnetic brake motor.

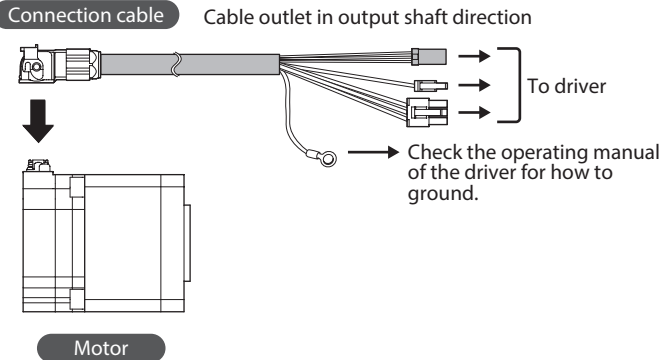

[Cable outlet direction]

Cable outlet in output shaft direction

CC__F

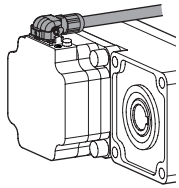

Cable outlet opposite to output shaft direction

CC__B

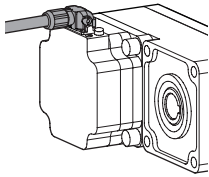

Cable outlet in vertical direction

CC__V

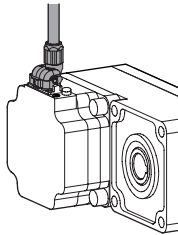

Note

- Do not apply a strong force on the locking lever of the connector for motor connection. Applying a strong force on the locking lever may cause damage.

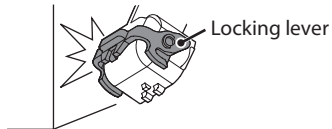

- Use the connection cable that the label for electromagnetic brake motor is attached. Failure to do so may result in damage to equipment.

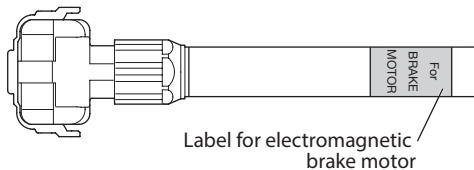

■ Connection procedures of the motor and connection cable

1 Remove

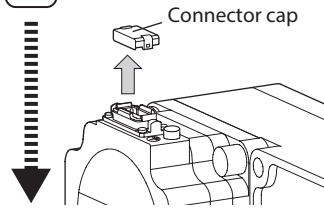

2 Attach

Check the cable outlet direction and insert the connector securely.

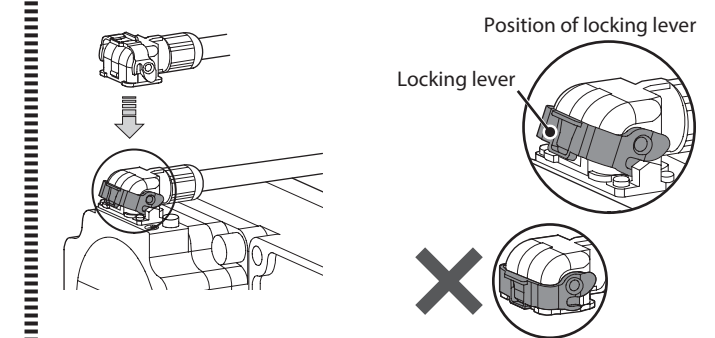

The connector cannot be inserted if the locking lever is turned down.

3 Secure

Secure the cable with the locking lever so that the cable does not come off.

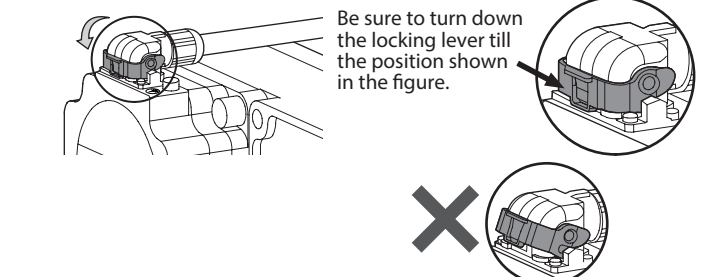

Secure the connector by turning down the locking lever completely.

Note

Do not lift up the product by holding the connection cable. Doing so may cause damage to the product.

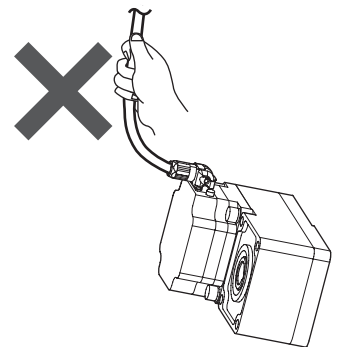

■ Detaching the connection cable

If the locking lever is turned up, the cable can be detached.

The connection cable for relay can be used by connecting up to 2 pieces. Check the operating manual included with the driver.

Grounding

Ground using the Protective Earth Terminals (⊕) of the motor and driver and the ground terminal of the connection cable. Check the operating manual of the driver for how to ground.

Note Be sure to ground the motor and driver. Failure to do so may result in electric shock or damage to the product. Static electricity may cause damage to the product if the Protective Earth Terminals are not grounded.

Inspection and maintenance

■ Inspection

It is recommended that periodic inspections would be conducted for the items listed below after each operation of the motor.
If an abnormal condition is noted, discontinue any use and contact your nearest Oriental Motor sales office.

Note Do not conduct the insulation resistance measurement or dielectric strength test with the motor and driver connected. Conducting the insulation resistance measurement or dielectric strength test with the motor and driver connected may result in damage to the product.

● Inspection item

- Check if any of the mounting screws of the motor is loose.
- Check if the bearing part (ball bearings) of the motor generates unusual noises.
- Check if the bearing part (ball bearings) or gear meshing part of the gearhead generates unusual noises.
- Check if the output shaft and a load shaft are out of alignment.
- Check if a damage or stress is applied on the cable or the connection part between the cable and driver is loose.

■ Warranty

Check on the Oriental Motor Website for the product warranty.

■ Disposal

Dispose the product correctly in accordance with laws and regulations, or instructions of local governments.

Specifications

Check on the Oriental Motor Website for the product specifications.

General specifications

Operating environment	Ambient temperature	0 to +40 °C [+32 to +104 °F] (non-freezing)
	Ambient humidity	85% or less (non-condensing)
	Altitude	Up to 1000 m (3300 ft.) above sea level
	Surrounding atmosphere	No corrosive gas, dust. Cannot be used in radioactive materials, magnetic field, vacuum or other special environment.
Vibration		Not subject to continuous vibrations or excessive impact. In conformance with JIS C 60068-2-6 "Sine-wave vibration test method" Frequency range: 10 to 55 Hz Pulsating amplitude: 0.15 mm Sweep direction: 3 directions (X, Y, Z) Number of sweeps: 20 times
Storage environment Shipping environment	Ambient temperature	-20 to +70 °C [-4 to +158 °F] (non-freezing)
	Ambient humidity	85% or less (non-condensing)
	Altitude	Up to 3000 m (10000 ft.) above sea level
Surrounding atmosphere		No corrosive gas, dust, water or oil. Cannot be used in radioactive materials, magnetic field, vacuum or other special environment.
Degree of protection		IP65 (When the connection cable is installed to the motor. Excluding the part of the connectors for driver connection.)

Regulations and standards

■ UL Standards and CSA Standards

This product is recognized by UL under the UL and CSA Standards.

■ CE Marking/UKCA Marking

This product is affixed with the marks under the following directives / regulations.

● Low Voltage Directive

Installation conditions

Overvoltage category: II, Pollution degree: 3,
Protection against electric shock: Class I equipment

- This product cannot be used in IT power distribution systems.
- Isolate the connection cable, power-supply cable and other drive cables from the signal cables by means of double insulation.

■ EU RoHS Directive/UK RoHS Regulation

This product does not contain the substances exceeding the restriction values.

- Unauthorized reproduction or copying of all or part of this manual is prohibited.
- Oriental Motor shall not be liable whatsoever for any problems relating to industrial property rights arising from use of any information, circuit, equipment or device provided or referenced in this manual.
- Characteristics, specifications and dimensions are subject to change without notice.
- While we make every effort to offer accurate information in the manual, we welcome your input. Should you find unclear descriptions, errors or omissions, please contact the nearest office.
- **Orientalmotor** is a registered trademark or trademark of Oriental Motor Co., Ltd., in Japan and other countries.

© Copyright ORIENTAL MOTOR CO., LTD. 2019

Published in February 2024

- Please contact your nearest Oriental Motor office for further information.

ORIENTAL MOTOR U.S.A. CORP.
Technical Support Tel:800-468-3982
8:30am EST to 5:00pm PST (M-F)

ORIENTAL MOTOR (EUROPA) GmbH
Schiesstraße 44, 40549 Düsseldorf, Germany
Technical Support Tel:00 800/22 55 66 22

ORIENTAL MOTOR (UK) LTD.
Unit 5 Faraday Office Park, Rankine Road,
Basingstoke, Hampshire RG24 8QB UK
Tel:+44-1256347090

ORIENTAL MOTOR (FRANCE) SARL
Tel:+33-1 47 86 97 50

ORIENTAL MOTOR ITALIA s.r.l.
Tel:+39-02-93906347

ORIENTAL MOTOR CO., LTD.
4-8-1 Higashiueno, Taito-ku, Tokyo 110-8536
Japan
Tel:+81-3-6744-0361
www.orientalmotor.co.jp/ja

ORIENTAL MOTOR ASIA PACIFIC PTE. LTD.
Singapore
Tel:1800-842-0280

ORIENTAL MOTOR (MALAYSIA) SDN. BHD.
Tel:1800-806-161

ORIENTAL MOTOR (THAILAND) CO., LTD.
Tel:1800-888-881

ORIENTAL MOTOR (INDIA) PVT. LTD.
Tel:1800-120-1995 (For English)
1800-121-4149 (For Hindi)

TAIWAN ORIENTAL MOTOR CO., LTD.
Tel:0800-060708

SHANGHAI ORIENTAL MOTOR CO., LTD.
Tel:400-820-6516

INA ORIENTAL MOTOR CO., LTD.
Korea
Tel:080-777-2042