

Brushless Motor

BLV Series R Type Motor

OPERATING MANUAL

Before using the product

Safety precautions

Precautions for use

Checking the product

Installation

Connection and grounding

Inspection and maintenance

Cables and accessories

Specifications

Regulations and standards

Thank you for purchasing an Oriental Motor product.

This Operating Manual describes product handling procedures and safety precautions.

- Please read it thoroughly to ensure safe operation.
- Always keep the manual where it is readily available.

Table of contents

1	Before using the product.....	3
2	Safety precautions.....	4
3	Precautions for use.....	6
4	Checking the product.....	8
4-1	Package contents.....	8
4-2	How to identify the product model.....	9
4-3	Information about nameplate.....	10
4-4	Products possible to combine.....	11
4-5	Names and functions of parts.....	13
5	Installation.....	14
5-1	Installation location.....	14
5-2	How to Install the motor.....	14
5-3	Installing a load.....	19
5-4	Permissible radial load and permissible axial load.....	21
6	Connection and grounding.....	23
6-1	Connecting the motor and the connection cable (Connector Type).....	23
6-2	Grounding the motor.....	23
7	Inspection and maintenance.....	24
7-1	Inspection.....	24
7-2	Warranty.....	24
7-3	Disposal.....	24
8	Cables and accessories.....	25
9	Specifications.....	26
10	Regulations and standards.....	27

1 Before using the product

Only qualified personnel of electrical and mechanical engineering should work with the product.

Use the product correctly after thoroughly reading the section "2 Safety precautions." In addition, be sure to observe the contents described in warning, caution, and note in this manual.

The product described in this manual is designed and manufactured to be incorporated in general industrial equipment. Do not use for any other purpose.

For the power supply, use a DC power supply with reinforced insulation on its primary and secondary sides. Oriental Motor Co., Ltd. is not responsible for any compensation for damage caused through failure to observe this warning.

■ Related operating manuals

Operating manuals are not included with the product. Download them from Oriental Motor Website Download Page or contact your nearest Oriental Motor sales office.

Search for an operating manual by the model name shown on the nameplate.





Operating manual name
BLV Series R Type Motor OPERATING MANUAL (this document)
BLV Series R Type OPERATING MANUAL Installation and Connection Edition*
BLV Series R Type Driver: BLVD-KBRD OPERATING MANUAL Installation and Connection Edition
BLV Series R Type OPERATING MANUAL Function Edition
BLV Series R Type Driver CANopen Communication Profile

* Driver: **BLVD-KRD**

2 Safety precautions

The precautions described below are intended to ensure the safe and correct use of the product, and to prevent the customer and others from exposure to the risk of injury. Use the product only after carefully reading and fully understanding these instructions.

Description of signs

 WARNING	Handling the product without observing the instructions that accompany a "WARNING" symbol may result in serious injury or death.
 CAUTION	Handling the product without observing the instructions that accompany a "CAUTION" symbol may result in injury or property damage.
 Note	The items under this heading contain important handling instructions that the user should observe to ensure safe use of the product.
 memo	The items under this heading contain related information and contents to gain a further understanding of the text in this manual.



Explanation of graphic symbols









Indicates "prohibited" actions that must not be performed.



Indicates "compulsory" actions that must be performed.

 WARNING	
	<ul style="list-style-type: none"> • Do not use the product in explosive or corrosive environments, in the presence of flammable gases, in places subjected to splashing water, or near combustibles. Doing so may result in fire, electric shock, or injury. • Do not transport, install, connect or inspect the product while the power is supplied. Always turn off the power before carrying out these operations. This may result in electric shock or damage to equipment. • Do not use a motor without an electromagnetic brake in an application of vertical drive such as elevating equipment. If the alarm function (protective function) of the driver is activated, the motor will stop operating. This may cause the moving part to fall, resulting in injury or damage to equipment. • Do not use the brake mechanism of the electromagnetic brake motor as a safety brake. It is intended to hold the moving part and motor positions. Using it as a safety brake may result in injury or damage to equipment. • When using the electromagnetic brake motor in an application of vertical drive such as elevating equipment, be sure to check the load condition sufficiently before operating. If a load in excess of the rated torque is applied or the small torque limiting value is set, the load may fall. This may cause injury or damage to equipment. • Do not machine or modify the cable. Doing so may result in fire, electrical shock, or damage to equipment. • Do not forcibly bend, pull, or pinch the cable. Doing so may result in fire, electrical shock, or damage to equipment. • Do not touch the motor or driver when conducting the insulation resistance measurement or dielectric strength test. Accidental contact may result in electric shock. • Do not disassemble or modify the motor. Doing so may result in electric shock, injury, or damage to equipment. Refer all such internal inspections and repairs to the branch or sales office from which you purchased the product.

 WARNING	
	<ul style="list-style-type: none"> • Only qualified and educated personnel should be allowed to perform installation, connection, operation and inspection/troubleshooting of the product. Handling by unqualified and uneducated personnel may result in fire, electric shock, injury, or damage to equipment. • Use a motor and a driver only in the specified combination. An incorrect combination may cause fire, electric shock, or damage to equipment. • If the alarm function (protective function) of the driver is activated, remove the cause before resetting the alarm. Continuing the operation without removing the cause of the problem may result in malfunction of the motor, leading to injury or damage to equipment. • Install the motor in an enclosure. Inappropriate installation may result in injury. • Always turn off the power before performing maintenance or inspection. Failure to do so may result in electric shock.

 CAUTION	
	<ul style="list-style-type: none"> • Do not use the motor beyond its specifications. Doing so may result in fire, electric shock, injury, or damage to equipment. • Do not touch the motor while operating or immediately after stopping. The surface is hot, and this may cause a skin burn(s). • Keep the area around the motor free of combustible materials. Failure to do so may result in fire or a skin burn(s). • Do not leave anything around the motor that would obstruct ventilation. Doing so may result in damage to equipment. • Do not lift up the motor by holding the output shaft or the cable. Doing so may result in injury. • Do not touch the motor output shaft (shaft end or pinion) with bare hands. Doing so may result in injury. • When assembling the motor with the gearhead, exercise caution not to pinch your fingers or other parts of your body between the motor and gearhead. Injury may result. • When installing the motor in equipment, exercise caution not to pinch your fingers or other parts of your body between the product and equipment. Injury may result. • Do not touch the rotating part (output shaft) while operating the motor. Doing so may result in injury.
	<ul style="list-style-type: none"> • Securely install the motor to the mounting plate. Inappropriate installation may cause the motor to detach and fall, resulting in injury or damage to equipment. • Provide a cover over the rotating part (output shaft). Failure to do so may result in injury. • Securely install a load to the output shaft. Failure to do so may result in injury. • Be sure to ground the motor and driver to prevent them from being damaged by static electricity. Failure to do so may result in fire or damage to equipment. • The motor surface temperature may exceed 70 °C (158 °F) even under normal operating conditions. If the operator is allowed to approach the motor in operation, attach a warning label in a conspicuous position as shown in the figure. The surface is hot, and this may cause a skin burn(s). <div style="text-align: right; margin-top: 10px;">  Warning label </div>

3 Precautions for use

This section covers restrictions and requirements the user should consider when using the product.

■ Wiring

● Connecting a motor and a driver

The dedicated connection cable (sold separately) is required since a 60 W motor is the connector type. (p.13)

Use the dedicated connection cable (sold separately) when extending the wiring distance between the motor and the driver.

● Notes when the cable is used

Note the following points when the cable is used.

How to fix the cable

Fix the cable at the positions near the connector so that no stress due to the bending or self-weight of the cable is applied on the connector.

Also, do not excessively bend the cable near the connection part of the connector. Applying stress on the cable may cause poor contact or disconnection, leading to malfunction or heat generation.

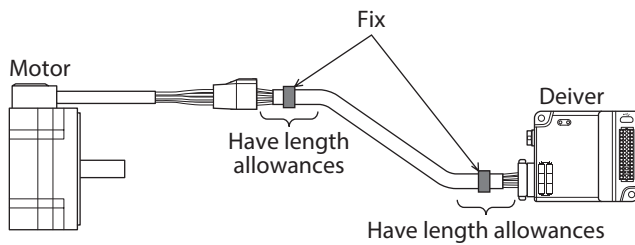

● Fixing at two places on each side

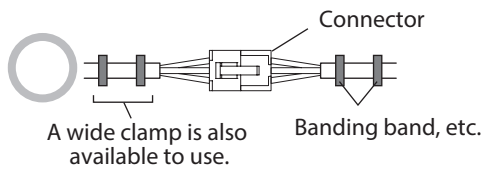

Fix using two cable ties or a wide clamp.

● Fixing at one place on each side

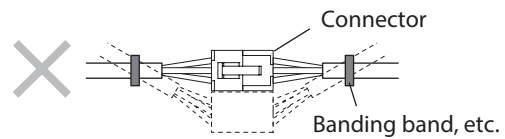

When the cable is moved, it causes the connectors to move, causing stress to apply on the connector part.

When bending the cable

Do not excessively bend the cable.

Applying stress on the cable may cause poor contact or disconnection, leading to malfunction or heat generation.

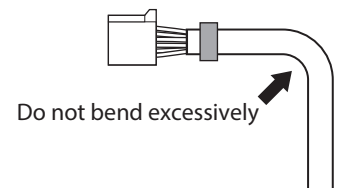

■ Installation

● Grease measures

On rare occasions, grease may ooze out from the gearhead. If there is concern over possible environmental contamination resulting from the leakage of grease, check for grease stains during regular inspections. Alternatively, install an oil pan or other device to prevent damage resulting from contamination. Grease leakage may lead to problems in the user's equipment or products.

● When using in low temperature environment

When an ambient temperature is low, a load torque may increase due to the oil seal or viscosity increment of grease used in the gearhead, and the output torque may decrease or the overload alarm may be generated. However, as time passes, the oil seal or grease is warmed up, and the motor can be operated without generating the overload alarm.

- **Apply grease to the hollow output shaft of a hollow shaft flat gearhead.**

When using a hollow shaft flat gearhead, apply grease (molybdenum disulfide grease, etc.) on the surface of the load shaft and inner walls of the hollow output shaft to prevent seizure.

- **Insulation resistance measurement and dielectric strength test**

- **Do not conduct the insulation resistance measurement or the dielectric strength test with the motor and driver connected.**

Conducting the insulation resistance measurement or dielectric strength test with the motor and driver connected may result in damage to the product.

- **Operations**

- **Use an electromagnetic brake motor in an application of vertical drive such as elevating equipment.**

When the motor is used in an application of vertical drive such as elevating equipment (lifting and lowering device), use an electromagnetic brake motor so that the load can be held in position.

- **The electromagnetic brake of the motor is used for holding the motor shaft.**

Actuating the electromagnetic brake to hold the motor shaft while the motor is rotating may result in damage to equipment.

- **Rotation direction of the gearhead output shaft**

Pinion shaft type/parallel shaft gearhead, CS geared motor

The rotation direction of the gearhead output shaft may vary with that of the motor output shaft depending on the gear ratio of the gearhead.

Gear ratio	Rotation direction of the gearhead output shaft
5, 10, 15, 20	Same direction as the motor output shaft
30, 50, 100*	Opposite direction to the motor output shaft

* Same direction as the motor output shaft when the gear ratio is 100 for the 200 W type

Pinion shaft type/hollow shaft flat gearhead

The rotation directions of the gearhead output shaft relative to the motor output shaft are as shown in the figures below.

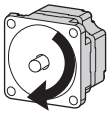
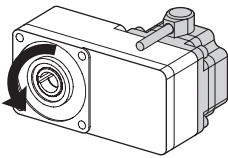
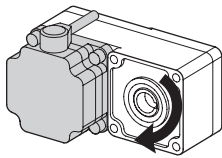
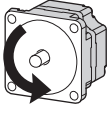
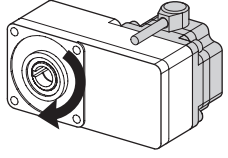
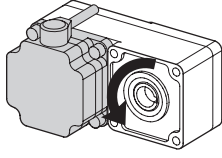
Motor output shaft	Gearhead output shaft	
	Front	Rear
		
		

- **Sliding noise of electromagnetic brake**

Sliding noise of the brake disk for the electromagnetic brake motor may be generated during operation. It is no functional problem.

4 Checking the product

4-1 Package contents

Verify that the items listed below are included.
Report any missing or damaged items to the branch or sales office from which you purchased the product.

■ Motor

● Pinion shaft type, Round shaft type

- Motor 1 unit
- Instructions and Precautions for Safe Use..... 1 copy

● CS geared motor

- Motor 1 unit
- Mounting screw 1 set
(hexagonal socket head screw, plain washer, spring washer: each 4 pieces, parallel key*: 1 piece)
- Instructions and Precautions for Safe Use..... 1 copy

* The parallel key is fixed to the gearhead output shaft.



The CS geared motor is a product that integrates a motor with a gearhead. Do not disassemble the gearhead from the motor.

■ Gearhead (sold separately)

● Parallel shaft gearhead

- Gearhead 1 unit
- Mounting screw 1 set
(hexagonal socket head screw, plain washer, spring washer: each 4 pieces, parallel key*: 1 piece)
- Screw for motor assembly..... 1 set
(Hexagonal socket head screw: 2 pieces)

* For the combination type of 200 W and 400 W the parallel key is fixed to the gearhead output shaft.

● Hollow shaft flat gearhead

- Gearhead 1 unit
- Mounting screw 1 set
(hexagonal socket head screw, plain washer, spring washer, nut*: each 4 pieces, parallel key: 1 piece)
- Screw for motor assembly..... 1 set
(Hexagonal socket head screw: 4 pieces)

- Safety cover 1 set
(safety cover: 1 piece, mounting screw for safety cover: 2 pieces)

* Nuts are not included with the 200 W and 400 W types.

4-2 How to identify the product model

● Cable type

BLMR **6** **200** **S** **K** **M** - **GFV** **F**
 1 2 3 4 5 7 8 9

● Connector type

BLMR **4** **60** **S** **H** **K** - **GFV**
 1 2 3 4 5 6 8

● CS geared motor

BLMR **2** **60** **H** **K** - **10** **CS**
 1 2 3 5 6 10 11

1	Motor type	BLMR: BLV Series R Type Motor
2	Frame size	2: 60 mm (2.36 in.) 4: 80 mm (3.15 in.) 5: 90 mm (3.54 in.) 6: 104 mm (4.09 in.)
3	Output power	60: 60 W 100: 100 W 200: 200 W 400: 400 W
4	Identification code	S
5	Motor connection method	H: Connector type
6	Power supply input	K: DC power input
7	Motor additional function	M: With electromagnetic brake
8	Motor shaft type	GFV: GFV pinion shaft type A: Round shaft type
9	Cable outlet direction	F: Output shaft side B: Opposite to output shaft side
10	Gear ratio	Number: Gear ratio of gearhead
11	Gearhead type	CS: CS geared motor

4-3 Information about nameplate

The figure shows an example.



The position describing the information may vary depending on the product.

■ Motor

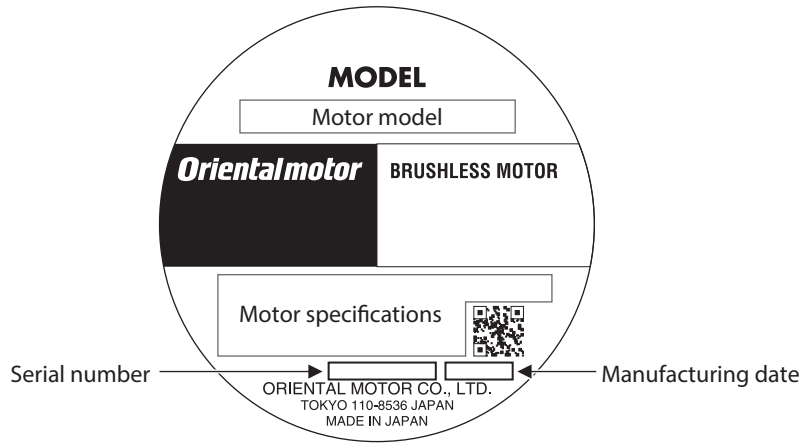

■ Gearhead

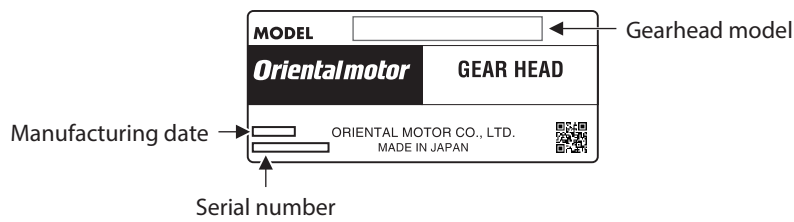

4-4 Products possible to combine

Verify the model name of the purchased product against the model shown on the nameplate.

- The box (□) in the model name indicates a number representing the gear ratio.
- The box (◆) in the model name indicates **F** or **B** representing the cable outlet direction.

■ Applicable driver: BLVD-KRD

● Pinion shaft type/parallel shaft gearhead

Output power	Motor model	Applicable gearhead model
60 W	BLMR460SHK-GFV	GFV4G□
100 W	BLMR5100K-GFV-◆	GFV5G□
200 W	BLMR6200SK-GFV-◆	GFV6G□
400 W	BLMR6400SK-GFV-◆	

● Pinion shaft type/hollow shaft flat gearhead

Output power	Motor model	Applicable gearhead model
60 W	BLMR460SHK-GFV	GFS4G□FR
100 W	BLMR5100K-GFV-◆	GFS5G□FR
200 W	BLMR6200SK-GFV-◆	GFS6G□FR
400 W	BLMR6400SK-GFV-◆	

● CS geared motor

Output power	Motor model
60 W	BLMR260HK-□CS

● Round shaft type

Output power	Motor model
60 W	BLMR460HK-A
100 W	BLMR5100K-A-◆
200 W	BLMR5200K-A-◆
400 W	BLMR5400K-A-◆

● Pinion shaft type with electromagnetic brake/parallel shaft gearhead

Output power	Motor model	Applicable gearhead model
100 W	BLMR5100KM-GFV-◆	GFV5G□
200 W	BLMR6200SKM-GFV-◆	GFV6G□
400 W	BLMR6400SKM-GFV-◆	

● Pinion shaft type with electromagnetic brake/hollow shaft flat gearhead

Output power	Motor model	Applicable gearhead model
100 W	BLMR5100KM-GFV-◆	GFS5G□FR
200 W	BLMR6200SKM-GFV-◆	GFS6G□FR
400 W	BLMR6400SKM-GFV-◆	

● Round shaft type with electromagnetic brake

Output power	Motor model
100 W	BLMR5100KM-A-◆
200 W	BLMR5200KM-A-◆
400 W	BLMR5400KM-A-◆

■ **Applicable driver: BLVD-KBRD**

● **Pinion shaft type/parallel shaft gearhead**

Output power	Motor model	Applicable gearhead model
400 W	BLMR6400SK-GFV-◆	GFV6G□

● **Pinion shaft type/hollow shaft flat gearhead**

Output power	Motor model	Applicable gearhead model
400 W	BLMR6400SK-GFV-◆	GFS6G□FR

● **Round shaft type**

Output power	Motor model
400 W	BLMR5400K-A-◆

● **Pinion shaft type with electromagnetic brake/parallel shaft gearhead**

Output power	Motor model	Applicable gearhead model
400 W	BLMR6400SKM-GFV-◆	GFV6G□

● **Pinion shaft type with electromagnetic brake/hollow shaft flat gearhead**

Output power	Motor model	Applicable gearhead model
400 W	BLMR6400SKM-GFV-◆	GFS6G□FR

● **Round shaft type with electromagnetic brake**

Output power	Motor model
400 W	BLMR5400KM-A-◆

4-5 Names and functions of parts

● Cable type (Example: Pinion shaft type with electromagnetic brake/parallel shaft gearhead)

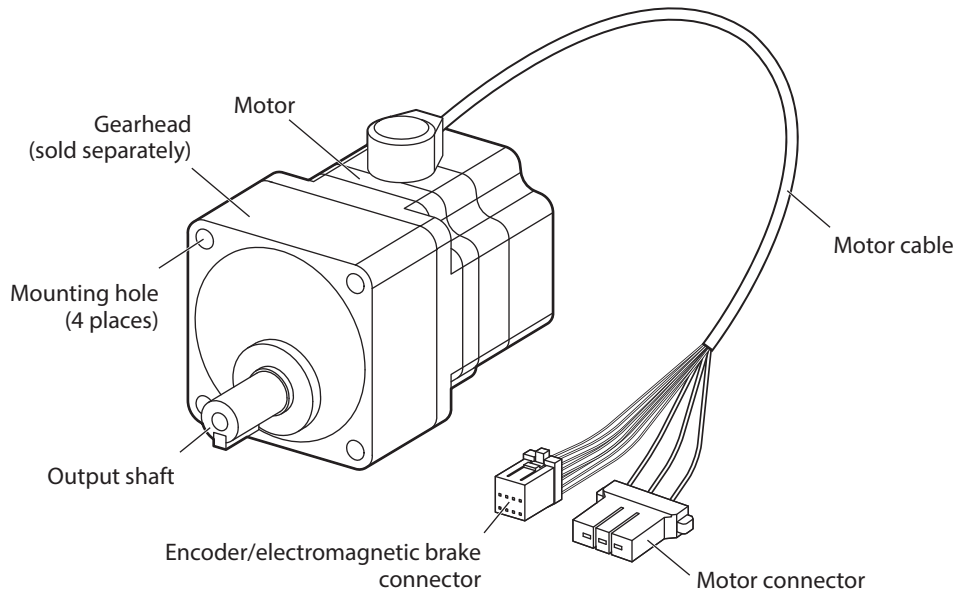

● Connector type (Example: CS geared motor)

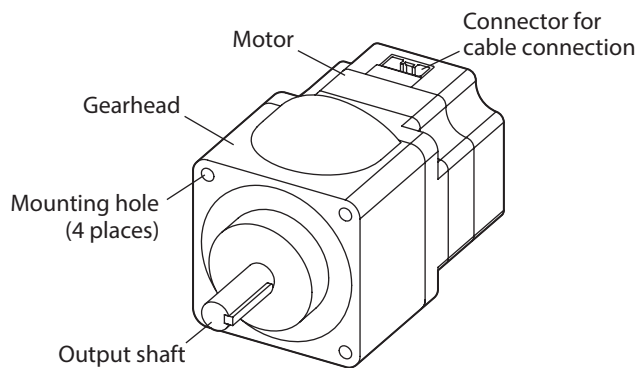

Connection cable (sold separately)

The dedicated connection cable (sold separately) is required since a 60 W motor is the connector type. The maximum extension distance is 3 m (9.8 ft.).

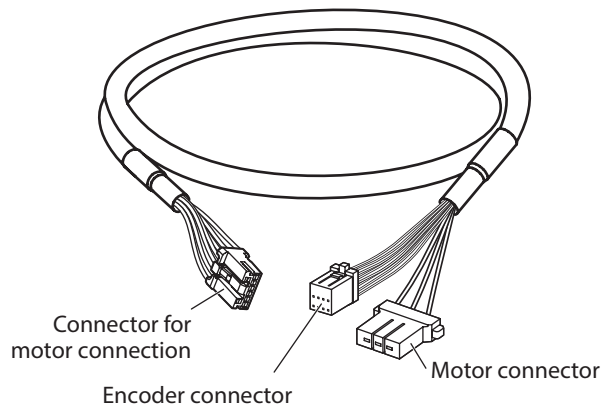

● Connection cable

Cable length	Model
0.3 m (0.98 ft.)	CCM003B1ABF
1 m (3.3 ft.)	CCM010B1ABF
2 m (6.6 ft.)	CCM020B1ABF
3 m (9.8 ft.)	CCM030B1ABF

● Flexible connection cable

Cable length	Model
1 m (3.3 ft.)	CCM010B1ABR
2 m (6.6 ft.)	CCM020B1ABR
3 m (9.8 ft.)	CCM030B1ABR

5 Installation

5-1 Installation location

The driver are designed and manufactured to be incorporated in equipment. Install them in a well-ventilated location that provides easy access for inspection. The location must also satisfy the following conditions:

- Inside an enclosure that is installed indoors (provide vent holes)
- Operating ambient temperature: 0 to +40 °C [+32 to +104 °F] (non-freezing)
- Operating ambient humidity: 85% or less (non-condensing)
- Area free of explosive atmosphere, toxic gas (such as sulfuric gas), or liquid
- Area not exposed to direct sun
- Area free of excessive amount of dust, iron particles or the like
- Area not subject to splashing water (rain, water droplets), oil (oil droplets) or other liquids
- Area free of excessive salt
- Area not subject to continuous vibration or excessive shocks
- Area free of excessive electromagnetic noise (from welders, power machinery, etc.)
- Area free of radioactive materials, magnetic fields or vacuum
- Up to 1000 m (3300 ft.) above sea level

5-2 How to Install the motor

■ Pinion shaft type/parallel shaft gearhead

● Assembling the gearhead to the motor

1. Keep the pilot sections of the motor and gearhead in parallel, and assemble the gearhead with the motor while slowly rotating it clockwise/counterclockwise. At this time, note so that the motor output shaft does not hit the side panel or gears of the gearhead strongly.

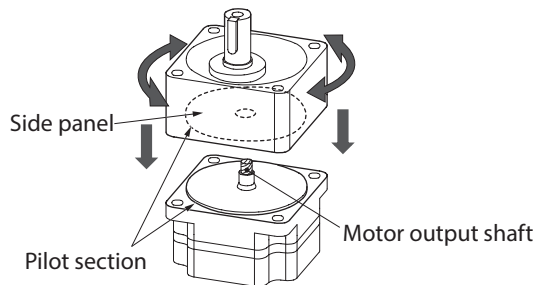

Assemble the gearhead to the motor in a condition where the motor output shaft is set upward.

2. Check that there is no gap between the motor and the gearhead, and tighten them with hexagonal socket head screws (2 places) included with gearheads.

Motor model	Screw size	Tightening torque [N·m (lb-in)]
BLMR460	M2.6	0.4 (3.5)
BLMR5100 BLMR6200 BLMR6400	M3	0.6 (5.3)

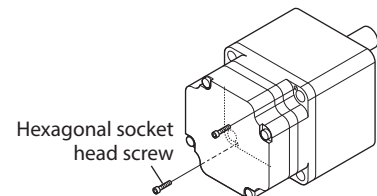

Note

- Do not forcibly assemble the motor and gearhead. Also, prevent metal objects or foreign substances from entering in the gearhead. The pinion of the motor output shaft or gear may be damaged, resulting in noise or shorter service life.
- Do not allow dust to attach to the pilot sections of the motor and gearhead. Also, assemble the motor and gearhead carefully by not pinching the O-ring at the motor pilot section. If the O-ring is crushed or severed, grease may leak from the gearhead.

● **Installing to mounting plate**

Secure the motor and gearhead through four mounting holes using the mounting screw set included with gearheads. Install so that there is no gap between the product and the mounting plate.

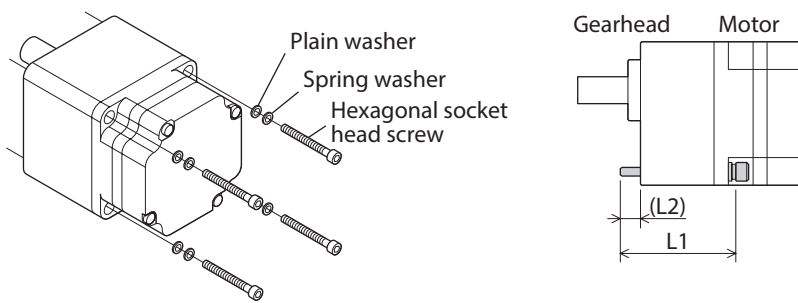

Motor model	Gear ratio	Hexagonal socket head screw (Material: Stainless steel)		L2 [mm (in.)]	Tightening torque [N·m (lb-in)]
		Screw size	L1 [mm (in.)]		
BLMR460	5 to 20	M6	60 (2.36)	8 (0.31)	5.0 (44)
	30 to 100		65 (2.56)		
	200		70 (2.76)		
BLMR5100	5 to 20	M8	70 (2.76)	11.5 (0.45)	12.0 (106)
	30 to 100		85 (3.35)	13.5 (0.53)	
	200		90 (3.54)	12.5 (0.49)	
BLMR6200 BLMR6400	5 to 20		85 (3.35)	11 (0.43)	
	30, 50		100 (3.94)	14 (0.55)	
	100, 200		110 (4.33)	10 (0.39)	

■ Pinion shaft type/hollow shaft flat gearhead

● Assembling the gearhead to the motor

1. Keep the pilot sections of the motor and gearhead in parallel, and assemble the gearhead with the motor while slowly rotating it clockwise/counterclockwise.
At this time, note so that the pinion of the motor output shaft does not hit the side panel or gears of the gearhead strongly.

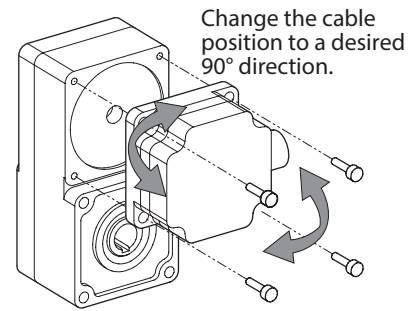

2. Check that there is no gap between the motor and the gearhead, and tighten them with hexagonal socket head screws (4 places).

Motor model	Screw size	Tightening torque [N·m (lb-in)]
BLMR460	M6	6.4 (56)
BLMR5100 BLMR6200 BLMR6400	M8	15.5 (137)

Note

- Do not forcibly assemble the motor and gearhead. Also, prevent metal objects or foreign substances from entering in the gearhead. The pinion of the motor output shaft or gear may be damaged, resulting in noise or shorter service life.
- Do not allow dust to attach to the pilot sections of the motor and gearhead. Also, assemble the motor and gearhead carefully by not pinching the O-ring at the motor pilot section. If the O-ring is crushed or severed, grease may leak from the gearhead.

● Installing to mounting plate

A combination type-hollow shaft flat gearhead can be installed by using either its front or rear side as the mounting surface.

Using the included mounting screw set, secure through the four mounting holes so that there is no gap between the product and the mounting plate. Nuts are not included with the 200 W and 400 W types. Provide nuts separately or drill tapped holes in the mounting plate.

Attach the included safety cover to the hollow output shaft on the end opposite from the one where the load shaft is installed.

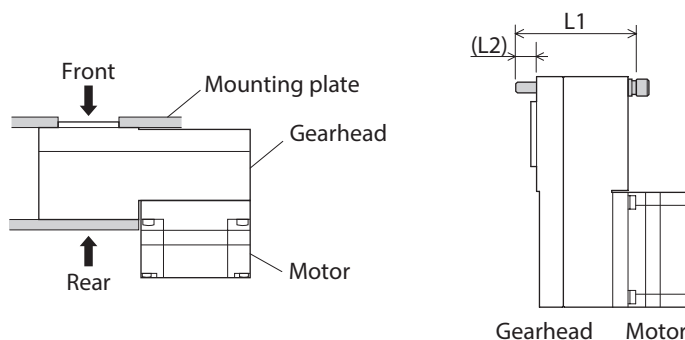

Motor model	Hexagonal socket head screw (Material: Carbon steel)		L2 [mm (in.)]	Tightening torque [N·m (lb-in)]
	Screw size	L1 [mm (in.)]		
BLMR460	M6	70 (2.76)	14 (0.55)	6.4 (56)
BLMR5100	M8	90 (3.54)	21 (0.83)	15.5 (137)
BLMR6200 BLMR6400		100 (3.94)	13 (0.51)	

● **Using the front side as the mounting surface**

When the gearhead is installed using its front side as the mounting surface, use the mounting boss of the output shaft to align the center axes of the hollow shaft and the load shaft.

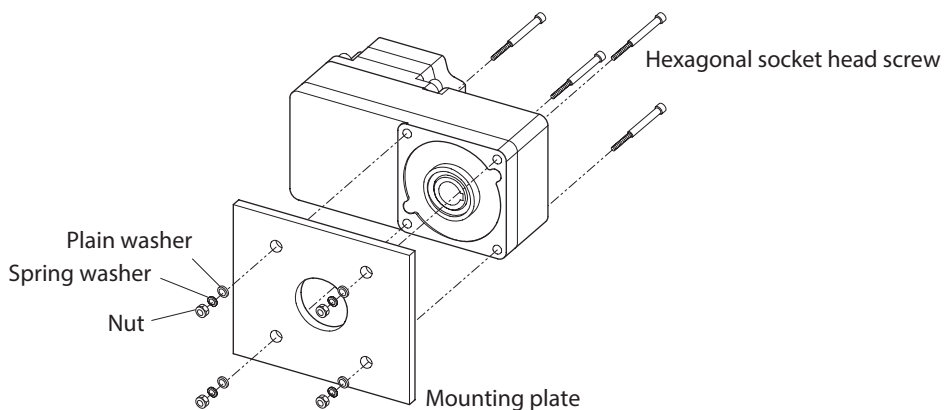

● **Using the rear side as the mounting surface**

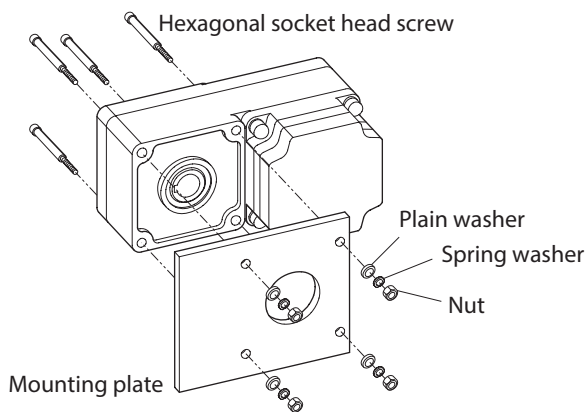

● **Installing the safety cover**

After installing a load, attach the included safety cover. The safety cover can be attached to either side. Tightening torque: 0.45 N.m (3.9 lb-in)

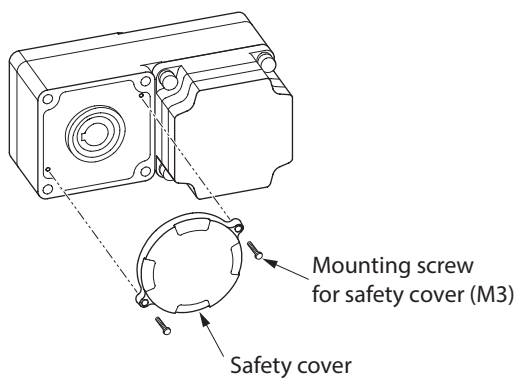

■ CS geared motor

Secure the motor and gearhead through four mounting holes using the included mounting screw set. Install so that there is no gap between the product and the mounting plate.

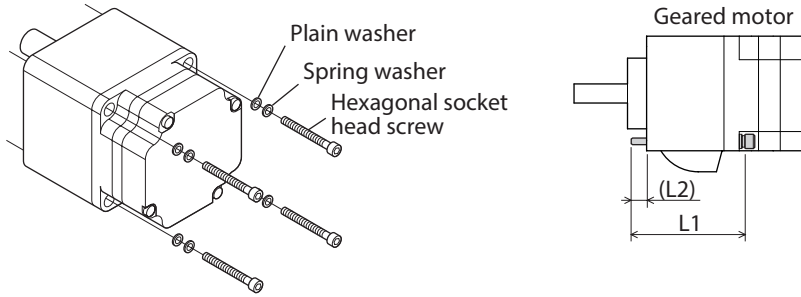

Motor model	Gear ratio	Hexagonal socket head screw (Material: Stainless steel)		L2 [mm (in.)]	Tightening torque [N·m (lb-in)]
		Screw size	L1 [mm (in.)]		
BLMR260	5 to 20	M4	60 (2.36)	10 (0.39)	2.0 (17.7)

Note The **CS** geared motor is a product that integrates a motor with a gearhead. Do not disassemble the gearhead from the motor.

■ Round shaft type

Secure the motor using the hexagonal socket head screws (not supplied) through the four mounting holes. Install so that there is no gap between the product and the mounting plate.

Applicable mounting screws

Motor model	Screw size	Tightening torque [N·m (lb-in)]*
BLM260	M4	1.8 (15.9) [1.4 (12.3)]
BLMR5100 BLMR5200 BLMR5400	M8	15.5 (137) [12.0 (106)]

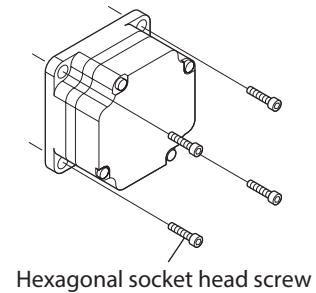

* The value in the brackets [] indicates when the material is stainless steel.

Install the motor to a mounting plate of the following size or larger, so that the motor case temperature will not exceed 90 °C (194 °F).

The temperature inside the motor can be monitored using the support software or the host controller.

Motor model	Size of heat sink [mm (in.)]	Thickness [mm (in.)]	Material
BLM260	135×135 (5.31×5.31)	5 (0.20)	Aluminum alloy
BLMR5100	165 x 165 (6.50 x 6.50)		
BLMR5200	200 × 200 (7.87 x 7.87)		
BLMR5400	250 × 250 (9.84 × 9.84)	6 (0.24)	

Note Do not install the motor to the mounting hole diagonally or assemble the motor forcibly. Doing so may cause damage to the flange pilot section, thereby resulting in damage to the motor.

5-3 Installing a load

■ Pinion shaft type/parallel shaft gearhead, CS geared motor, round shaft type

When installing a load on the motor or the gearhead, pay attention to the following points.

- Align the center axis of the motor output shaft or the gearhead output shaft with that of the load.
- A key slot is provided on the output shaft for the combination type-parallel shaft gearhead and the CS geared motor. Form a key slot on the load side and secure the load using the parallel key.

Note

- When coupling the motor or the gearhead with a load, pay attention to centering, belt tension, parallelism of pulleys, etc. Also, firmly secure the tightening screws of the coupling or pulleys.
- When installing a load, do not damage the motor output shaft (gearhead output shaft) or bearings. Installing the load forcibly with a hammer or the like may break the bearings. Do not apply any excessive force to the output shaft.
- Do not modify or machine the output shaft of the motor or gearhead. This may damage the bearing, resulting in damage to the motor or gearhead.

When using the output shaft end tapped hole of a gearhead

Use a tapped hole provided at the end of the output shaft as an auxiliary means for preventing the transfer mechanism from disengaging.

Gearhead model	Screw size	Effective depth of screw
GFV4G	M5	10 mm (0.39 in.)
GFV5G GFV6G	M6	12 mm (0.47 in.)

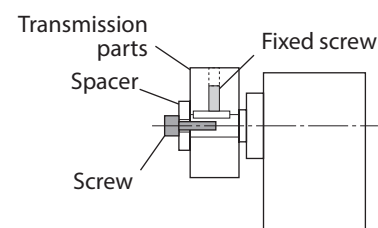

■ Pinion shaft type/hollow shaft flat gearhead

If a large impact occurs at instantaneous stop or a large radial load is applied, use a stepped load shaft.

- Note**
- Apply grease (molybdenum disulfide grease, etc.) on the surface of the load shaft and inner walls of the hollow output shaft to prevent seizure.
 - When installing a load, do not damage the output shaft or the bearings. Installing the load forcibly with a hammer or the like may break the bearings. Do not apply any excessive force to the output shaft.
 - Do not modify or machine the output shaft.
This may damage the bearing, resulting in damage to the motor and gearhead.

● Stepped load shaft

Secure the retaining ring for hole to the load shaft by tightening the hexagonal socket head screw over a spacer, plain washer and spring washer.

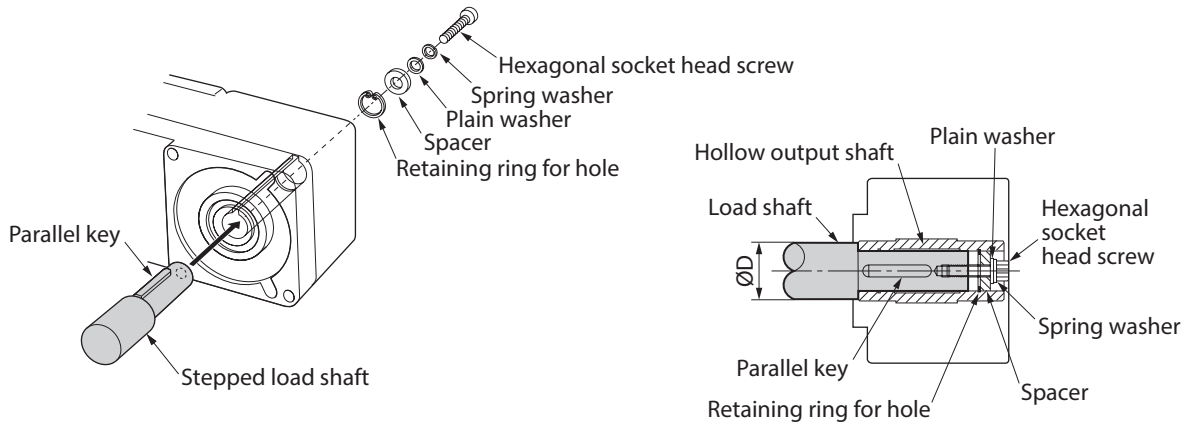

● Non-stepped load shaft

Install a spacer on the load shaft side and secure the retaining ring for hole to the load shaft by tightening the hexagonal socket head screw over a spacer, flat washer and spring washer.

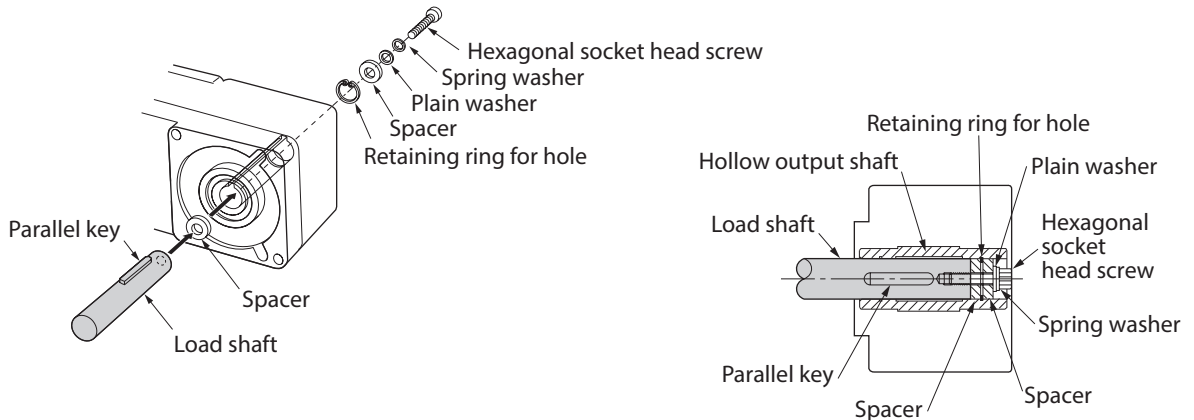

Recommended load shaft installation dimensions [Unit: mm (in.)]

Motor model	Inner diameter of hollow shaft (H8)	Recommended diameter of load shaft (h7)	Nominal diameter of retaining ring	Applicable screw	Spacer thickness	Outer diameter of stepped shaft (ØD)
BLMR460	$\varnothing 15^{+0.027}_0$ ($\varnothing 0.5906^{+0.0011}_0$)	$\varnothing 15^{0}_{-0.018}$ ($\varnothing 0.5906^{0}_{-0.0007}$)	$\varnothing 15$ ($\varnothing 0.59$)	M5	4 (0.16)	25 (0.98)
BLMR5100	$\varnothing 20^{+0.033}_0$ ($\varnothing 0.7874^{+0.0013}_0$)	$\varnothing 20^{0}_{-0.021}$ ($\varnothing 0.7874^{0}_{-0.0008}$)	$\varnothing 20$ ($\varnothing 0.79$)	M6	5 (0.20)	30 (1.18)
BLMR6200 BLMR6400	$\varnothing 25^{+0.033}_0$ ($\varnothing 0.9843^{+0.0013}_0$)	$\varnothing 25^{0}_{-0.021}$ ($\varnothing 0.9843^{0}_{-0.0008}$)	$\varnothing 25$ ($\varnothing 0.98$)	M8	6 (0.24) [3 (0.12)] *	40 (1.57)

* The value in the brackets [] is that when using the rear side as the mounting surface.

5-4 Permissible radial load and permissible axial load

Make sure a radial load and axial load applied to the output shaft will not exceed the permissible values shown in the table below.



Failure due to fatigue may occur when the bearings and output shaft are subject to repeated loading by a radial or axial load that is in excess of the permissible limit.

■ Pinion shaft type/parallel shaft gearhead, CS geared motor

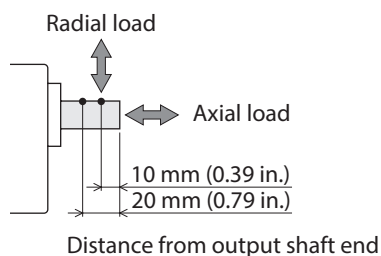

Motor model	Gear ratio	Permissible radial load [N (lb.)]*		Permissible axial load [N (lb.)]
		Distance from output shaft end of the gearhead		
		10 mm (0.39 in.)	20 mm (0.79 in.)	
BLMR260	5	150 (33)	190 (42)	70 (15.7)
	10 to 20	200 (45)	260 (58)	
BLMR460	5	200 (45) [180 (40)]	250 (56) [220 (49)]	100 (22)
	10 to 20	300 (67) [270 (60)]	350 (78) [330 (74)]	
	30 to 200	450 (101) [420 (94)]	550 (123) [500 (112)]	
BLMR5100	5	300 (67) [230 (51)]	400 (90) [370 (83)]	150 (33)
	10 to 20	400 (90) [370 (83)]	500 (112) [430 (96)]	
	30 to 200	500 (112) [450 (101)]	650 (146) [550 (123)]	
BLMR6200 BLMR6400	5 to 20	550 (123) [500 (112)]	800 (180) [700 (157)]	200 (45)
	30, 50	1000 (220) [900 (200)]	1250 (280) [1100 (240)]	300 (67)
	100, 200	1400 (310) [1200 (270)]	1700 (380) [1400 (310)]	400 (90)

* The values assume a rated speed of 3000 r/min or below. The values in brackets [] are based on a rated speed of 4000 r/min.

■ Round shaft type

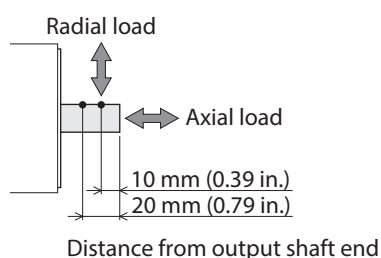

Motor model	Permissible radial load [N (lb.)]		Permissible axial load [N (lb.)]
	Distance from output shaft end of the motor		
	10 mm (0.39 in.)	20 mm (0.79 in.)	
BLMR260	70 (15.7)	100 (22)	15 (3.3)
BLMR5100 BLMR5200 BLMR5400	150 (33)	170 (38)	25 (5.6)

■ Pinion shaft type/hollow shaft flat gearhead

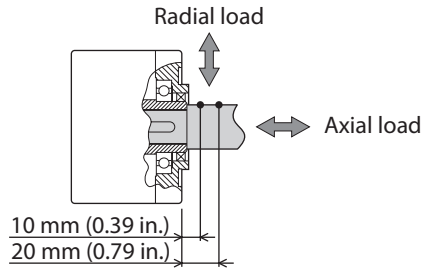

Distance from mounting surface

Motor model	Gear ratio	Permissible radial load [N (lb.)]* 1 Distance from gearhead mounting surface		Permissible axial load [N (lb.)]
		10 mm (0.39 in.)	20 mm (0.79 in.)	
BLMR460	5, 10	800 (180) [730 (164)]	660 (148) [600 (135)]	400 (90)
	15 to 200	1200 (270) [1100 (240)]	1000 (220) [910 (200)]	
BLMR5100	5, 10	900 (200) [820 (184)]	770 (173) [700 (157)]	500 (112)
	15, 20	1300 (290) [1200 (270)]	1110 (240) [1020 (220)]	
	30 to 200	1500 (330) [1400 (310)]	1280 (280) [1200 (270)]	
BLMR6200 BLMR6400	5*2, 10	1230 (270) [1130 (250)]	1070 (240) [990 (200)]	800 (180)
	15, 20	1680 (370) [1550 (340)]	1470 (330) [1360 (300)]	
	30 to 100	2040 (450) [1900 (420)]	1780 (400) [1660 (370)]	

*1 The values assume a rated speed of 3000 r/min or below. The values in brackets [] are based on a rated speed of 4000 r/min.

*2 400 W type only

6 Connection and grounding

6-1 Connecting the motor and the connection cable (Connector Type)

The dedicated connection cable (sold separately) is required since a 60 W motor is the connector type.

● Connector

Hold the connector main body of the connection cable, and insert the connector until making a clicking noise.

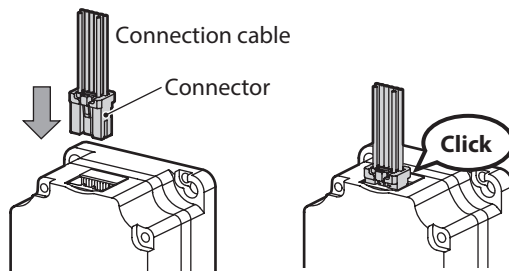

● Removing

Hold the connector main body and pull out the connector while pressing the connector lock. Do not apply stress on the connection part of the lead wires and connector.

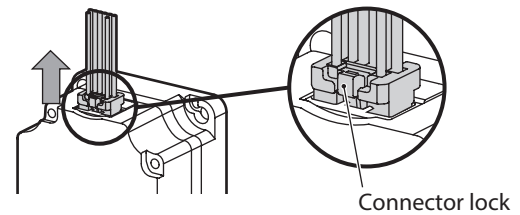

Note

- Connect the connectors securely. Insecure connector connections may cause malfunction or damage to the product.
- Be sure to insert and pull out the connector while holding the connector part. Do not apply any force in a direction other than the direction of inserting and pulling out the connector. Applying improper force may cause damage to the product.
- Do not lift up the product by holding the connection cable. Doing so may result in damage to the product.
- The number of times to connect/remove the connection cable to/from the motor should be 30 times or less as a guide. Increasing the number of times to connect/remove may cause malfunction or damage to the product.

6-2 Grounding the motor

- Install the motor to a grounded metal plate.
- Wires used to ground the motor and the driver must be as thick and short as possible so that no potential difference is generated between the grounding points.
- Choose a large, thick and uniformly conductive surface for the grounding point.

Note

Static electricity may cause damage to the products if they are not grounded.

7 Inspection and maintenance

7-1 Inspection

It is recommended that periodic inspections are conducted for the items listed below after each operation of the motor. If an abnormality is generated, discontinue any use and contact your nearest Oriental Motor sales office.

■ Inspection item

- Check if any of the mounting screws of the motor and gearhead is loose.
- Check if the bearing part (ball bearings) of the motor generates unusual noises.
- Check if the bearing part (ball bearings) or gear meshing part of the gearhead generates unusual noises.
- Check if the output shaft of the motor and gearhead and a load shaft are out of alignment.
- Check if a damage or stress is applied on the cable or the connection part between the cable and driver is loose.



The driver uses semiconductor components. Static electricity may damage the semiconductor components of the driver, so be extremely careful when handling them.

7-2 Warranty

Check on the Oriental Motor Website for the product warranty.

7-3 Disposal

Dispose the product correctly in accordance with laws and regulations, or instructions of local governments.

8 Cables and accessories

■ Connection cable

This cable is used to extend the wiring distance between the driver and motor.

The maximum extension distance including the cable length of the motor itself should be 3.5 m (11.5 ft.).

Length	Model
1 m (3.3 ft.)	CCM010B1AAF
2 m (6.6 ft.)	CCM020B1AAF
3 m (9.8 ft.)	CCM030B1AAF

■ Coupling, mounting bracket

Couplings and mounting brackets can be checked on the Oriental Motor Website.

About the mounting bracket (SOL) of the motor

If the motor is secured to the mounting bracket in a state where the cable outlet direction is set toward the output shaft side, the cable may obstruct and contact the mounting bracket or installation surface.

9 Specifications

■ Specifications

Check on the Oriental Motor Website for the product specifications.

■ General specifications

Degree of protection		IP40
Operating environment	Ambient temperature	0 to +40 °C (+32 to +104 °F) (non-freezing)
	Humidity	85% or less (non-condensing)
	Altitude	Up to 1000 m (3300 ft.) above sea level
	Surrounding atmosphere	No corrosive gas, dust, water or oil. Cannot be used in radioactive materials, magnetic field, vacuum or other special environments.
	Vibration	Not subject to continuous vibration or excessive impact. In conformance with JIS C 60068-2-6 "Sine-wave vibration test method" Frequency range: 10 Hz to 55 Hz Pulsating amplitude: 0.15 mm (0.006 in.) Sweep direction: 3 directions (X, Y, Z) Number of sweeps: 20 times
Storage environment	Ambient temperature	-20 to +70 °C [-4 to +158 °F] (non-freezing)
	Humidity	85% or less (non-condensing)
Shipping environment	Altitude	Up to 3000 m (10000 ft.) above sea level
	Surrounding atmosphere	No corrosive gas, dust, water or oil. Cannot be used in radioactive materials, magnetic field, vacuum or other special environments.

10 Regulations and standards

■ UL Standards, CSA Standards

This product is recognized by UL under the UL and CSA Standards.

■ CE Marking

This product is exempt from the CE marking.

Installation conditions

- For incorporating in equipment
- Overvoltage category: I
- Pollution degree: 2
- Protection against electric shock: Class III equipment
- * Thermal class EN Standards: 120 (E)

■ EU RoHS Directive/UK RoHS Regulation

This products do not contain the substances exceeding the restriction values.

- Unauthorized reproduction or copying of all or part of this manual is prohibited.
If a new copy is required to replace an original manual that has been damaged or lost, please contact your nearest Oriental Motor branch or sales office.
- Oriental Motor shall not be liable whatsoever for any problems relating to industrial property rights arising from use of any information, circuit, equipment or device provided or referenced in this manual.
- Characteristics, specifications and dimensions are subject to change without notice.
- While we make every effort to offer accurate information in the manual, we welcome your input. Should you find unclear descriptions, errors or omissions, please contact the nearest office.
- **Orientalmotor** is a registered trademark or trademark of Oriental Motor Co., Ltd., in Japan and other countries.
Other product names and company names mentioned in this manual may be registered trademarks or trademarks of their respective companies and are hereby acknowledged. The third-party products mentioned in this manual are recommended products, and references to their names shall not be construed as any form of performance guarantee. Oriental Motor is not liable whatsoever for the performance of these third-party products.

© Copyright ORIENTAL MOTOR CO., LTD. 2023

Published in November 2023

- Please contact your nearest Oriental Motor office for further information.

ORIENTAL MOTOR U.S.A. CORP.
Technical Support Tel:800-468-3982
8:30am EST to 5:00pm PST (M-F)

ORIENTAL MOTOR (EUROPA) GmbH
Schiesstraße 44, 40549 Düsseldorf, Germany
Technical Support Tel:00 800/22 55 66 22

ORIENTAL MOTOR (UK) LTD.
Unit 5 Faraday Office Park, Rankine Road,
Basingstoke, Hampshire RG24 8QB UK
Tel:+44-1256347090

ORIENTAL MOTOR (FRANCE) SARL
Tel:+33-1 47 86 97 50

ORIENTAL MOTOR ITALIA s.r.l.
Tel:+39-02-93906347

ORIENTAL MOTOR ASIA PACIFIC PTE. LTD.
Singapore
Tel:1800-842-0280

ORIENTAL MOTOR (MALAYSIA) SDN. BHD.
Tel:1800-806-161

ORIENTAL MOTOR (THAILAND) CO., LTD.
Tel:1800-888-881

ORIENTAL MOTOR (INDIA) PVT. LTD.
Tel:1800-120-1995 (For English)
1800-121-4149 (For Hindi)

TAIWAN ORIENTAL MOTOR CO., LTD.
Tel:0800-060708

SHANGHAI ORIENTAL MOTOR CO., LTD.
Tel:400-820-6516

INA ORIENTAL MOTOR CO., LTD.
Korea
Tel:080-777-2042

ORIENTAL MOTOR CO., LTD.
4-8-1 Higashiueno, Taito-ku, Tokyo
110-8536 Japan
Tel:+81-3-6744-0361
www.orientalmotor.co.jp/ja