



Brushless Motor

BLH Series Analog Setting Type 100 W

OPERATING MANUAL



Thank you for purchasing an Oriental Motor product.
This Operating Manual describes product handling procedures and safety precautions.

- Please read it thoroughly to ensure safe operation.
- Always keep the manual where it is readily available.

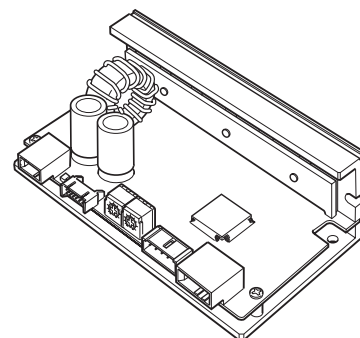

Table of contents

1	Introduction	2	7	Operation	15
2	Safety precautions	3	7.1	Input signals and output signals	15
3	Precautions for use	5	7.2	Rotation direction of the motor output shaft	18
4	Preparation	6	7.3	Setting the running speed	19
4.1	Checking the product	6	7.4	Setting the acceleration time and deceleration time	20
4.2	How to identify the product model	6	7.5	Multi-motor control	21
4.3	Information about nameplate	6	8	Maintenance and inspection	22
4.4	Products possible to combine	6	8.1	Inspection	22
4.5	Names and functions of parts	7	8.2	Warranty	22
5	Installation	8	8.3	Disposal	22
5.1	Installation location	8	9	Troubleshooting	23
5.2	Installing the driver	8	10	Specifications	24
6	Connection	9	10.1	Specifications	24
6.1	Connecting the motor and driver (CN3, CN4)	9	10.2	General specifications	24
6.2	Connecting the power supply (CN1)	9	10.3	Dimension	24
6.3	Connecting the I/O signals (CN2)	10	11	Regulations and standards	25
6.4	Driver I/O circuit and example connection	11	11.1	UL Standards and CSA Standards	25
6.5	Grounding	12	11.2	CE Marking	25
6.6	Connection diagram	12	11.3	RoHS Directive	25
6.7	Noise measures	13	11.4	Republic of Korea, Radio Waves Act	25
6.8	Conformity to the EMC Directive	13			

1 Introduction

■ Before using the product

Only qualified personnel of electrical and mechanical engineering should work with the product.

Use the product correctly after thoroughly reading the section "2 Safety precautions." In addition, be sure to observe the contents described in warning, caution, and note in this manual.

The product described in this manual has been designed and manufactured to be incorporated in general industrial equipment. Do not use for any other purpose. For the power supply, use a DC power supply with reinforced insulation on its primary and secondary sides. Oriental Motor Co., Ltd. is not responsible for any damage caused through failure to observe this warning.

■ Operating manuals for the product



Operating manuals for the **BLH** Series are listed below.

Operating manuals are not included with the product. Download from Oriental Motor Website Download Page or contact your nearest Oriental Motor sales office.

	Operating manual name	Operating manual number
Driver	BLH Series Analog Setting Type 100 W OPERATING MANUAL (this document)	HP-5098
Motor	BLHM Motor OPERATING MANUAL	HM-5238
	BLHM Electromagnetic Brake Motor OPERATING MANUAL	HM-5258



2 Safety precautions



The precautions described below are intended to ensure the safe and correct use of the product, and to prevent the user and other personnel from exposure to the risk of injury. Use the product only after carefully reading and fully understanding these instructions.

 WARNING	Handling the product without observing the instructions that accompany a "WARNING" symbol may result in serious injury or death.
 CAUTION	Handling the product without observing the instructions that accompany a "CAUTION" symbol may result in injury or property damage.
 Note	The items under this heading contain important handling instructions that the user should observe to ensure safe use of the product.

Explanation of graphic symbols  Indicates "prohibited" actions that must not be performed.

 Indicates "compulsory" actions that must be performed.

 WARNING	
	<ul style="list-style-type: none"> • Do not use the product in explosive or corrosive environments, in the presence of flammable gases, in places subjected to splashing water, or near combustibles. Doing so may result in fire or injury. • Do not transport, install, connect or inspect the product while the power is supplied. Always turn off the power before carrying out these operations. Damage to equipment may result. • Do not use a motor in vertical drive such as elevating equipment. When the driver protective function is activated, the motor will stop operating. The moving part may fall, leading to injury or damage to equipment. • Do not touch the motor or driver when conducting the insulation resistance measurement or dielectric strength test. Accidental contact may result in electric shock. • Do not disassemble or modify the driver. Doing so may cause injury or damage to equipment. Refer all such internal inspections and repairs to the branch or sales office from which you purchased the product.
	<ul style="list-style-type: none"> • Only qualified and educated personnel should be allowed to perform installation, connection, operation and inspection/troubleshooting of the product. Handling by unqualified and uneducated personnel may result in fire, injury or damage to equipment. • Use a motor and driver only in the specified combination. Failure to do so may result in fire or damage to equipment. • If the driver protective function was activated, remove the cause before resetting the protective function. Continuing the operation without removing the cause of the problem may cause malfunction of the motor, leading to injury or damage to equipment. • Install the driver in an enclosure. Failure to do so may result in injury. • Always keep the power supply voltage of the driver within the specified range. Failure to do so may result in fire. • Connect the cables securely according to the wiring example. Failure to do so may result in fire or damage to equipment. • Be sure to observe the specified cable sizes. Failure to do so may result in fire or damage to equipment. • For the driver power supply, use a DC power supply with reinforced insulation on its primary and secondary sides. Failure to do so may result in electric shock. • If the motor is operated by turning on and off the power supply, turn off the driver power in the event of a power failure. Otherwise, the motor may suddenly start when the power is restored, causing injury or damage to equipment. • Always turn off the power before performing maintenance or inspection. Failure to do so may result in electric shock.

 CAUTION	
	<ul style="list-style-type: none">• Do not use the driver beyond the specifications. Doing so may result in fire, injury or damage to equipment.• Do not touch the driver during operation or immediately after stopping. The surface is hot, and this may cause a skin burn(s).• Keep the area around the driver free of combustible materials. Failure to do so may result in fire or a skin burn(s).• Do not leave anything around the driver that would obstruct ventilation. Doing so may result in damage to equipment.• Do not shut off the negative side of the power supply. Also, make sure that the wiring for the power supply does not disconnect. This may result in damage to equipment.
	<ul style="list-style-type: none">• Securely install the driver to the mounting plate. Inappropriate installation may cause the driver to detach and fall, resulting in injury or damage to equipment.• Be sure to ground the motor and driver to prevent them from being damaged by static electricity. Failure to do so may result in fire or damage to equipment.• Pay enough attention to safe operation when starting and stopping the motor by switching ON-OFF of the power supply. Failure to do so may result in injury or damage to equipment.• Provide an emergency stop device or emergency stop circuit external to the equipment so that the entire equipment will operate safely in the event of a system failure or malfunction. Failure to do so may result in injury.• Immediately when trouble has occurred, stop operation and turn off the driver power. Failure to do so may result in fire, electric shock or injury.• Before turning on the power to the driver, make sure to turn all input signals of the driver to OFF. Otherwise, the motor may suddenly start when the power is on, leading to injury or damage to equipment.

3 Precautions for use

This chapter covers limitations and requirements the user should consider when using the product.

Be sure to match the output power of the driver with that of the motor when using.

- Do not perform gravitational operation (vertical drive).
If the **BLH** Series is used in operation (i.e. gravitational operation) in which the motor output shaft is turned from the load side, the motor speed cannot be controlled. In addition, a gravitational load operation will cause the driver's primary inverter voltage to exceed the allowable value, thereby triggering a protection function and causing the motor to stop spontaneously. If this happens, there is a possibility that the load will drop.
- Do not conduct the insulation resistance measurement or the dielectric strength test with the motor and driver connected.
Conducting the insulation resistance measurement or the dielectric strength test with the motor and driver connected may result in damage to the product.
- Note on power ON/OFF using a mechanical contact
When turning on or off the power supply using a mechanical contact (breaker, electromagnetic switch, relay, etc.), do so only the positive side (+) of the power supply using the mechanical contact.
Turning on or off the positive side (+) and the negative side (–) of the power supply simultaneously using a mechanical contact may cause damage to the control circuit or peripheral equipment.
Refer to p.9 for details.
- Noise elimination measures
Refer to p.13 for the noise elimination measures.
- Grease measures
On rare occasions, grease may ooze out from the gearhead. If there is concern over possible environmental contamination resulting from the leakage of grease, check for grease stains during regular inspections. Alternatively, install an oil pan or other device to prevent damage resulting from contamination. Grease leakage may lead to problems in the user's equipment or products.
- Apply grease to the hollow output shaft of a hollow shaft flat gearhead.
Apply grease (molybdenum disulfide grease, etc.) on the surface of the load shaft and the inner walls of the hollow output shaft to prevent seizure.
- Sliding noise of electromagnetic brake
Sliding noise of the brake disk for the electromagnetic brake motor may be generated during operation.
It is no functional problem.

4 Preparation

This chapter explains the items you should check, as well as the name and function of each part.

4.1 Checking the product

Verify that the items listed below are included.

Report any missing or damaged items to the branch or sales office from which you purchased the product.
Refer to "4.4 Products possible to combine" for combinations of the driver and motor.

Driver 1 unit

I/O signal cable (LH003C3) 1 pc [300 mm (11.8 in.)]

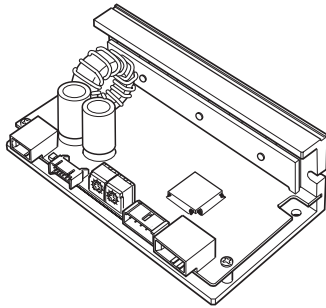

Power supply cable (LH003C2) 1 pc [300 mm (11.8 in.)]



Instructions and Precautions for Safe Use 1 copy

4.2 How to identify the product model

BLHD **100** **K**
① ② ③

①	Driver type	BLHD: BLH Series driver
②	Output power	100: 100 W
③	Power supply voltage	K: 24 VDC

4.3 Information about nameplate

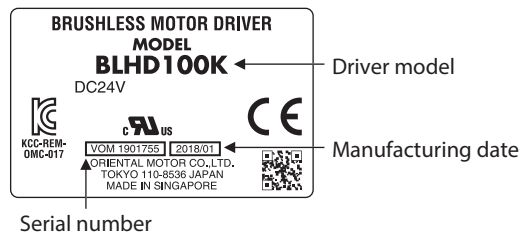

4.4 Products possible to combine

Products with which the drivers can be combined are listed below.

Verify the motor model and the driver model against the model name described on the nameplate of the product.

The box (□) in the motor model name indicates a code or a number representing the gear ratio, the shaft type, or the gearhead type.

For details about the motor, refer to the operating manual of the motor.

Output power	Motor model	Driver model
100 W	BLHM5100KC-□□* BLHM5100KCM-□□	BLHD100K

* For the lead wire type, "KC" of the motor model are replaced by "K"

4.5 Names and functions of parts

This section explains the name and function for each part of the driver.

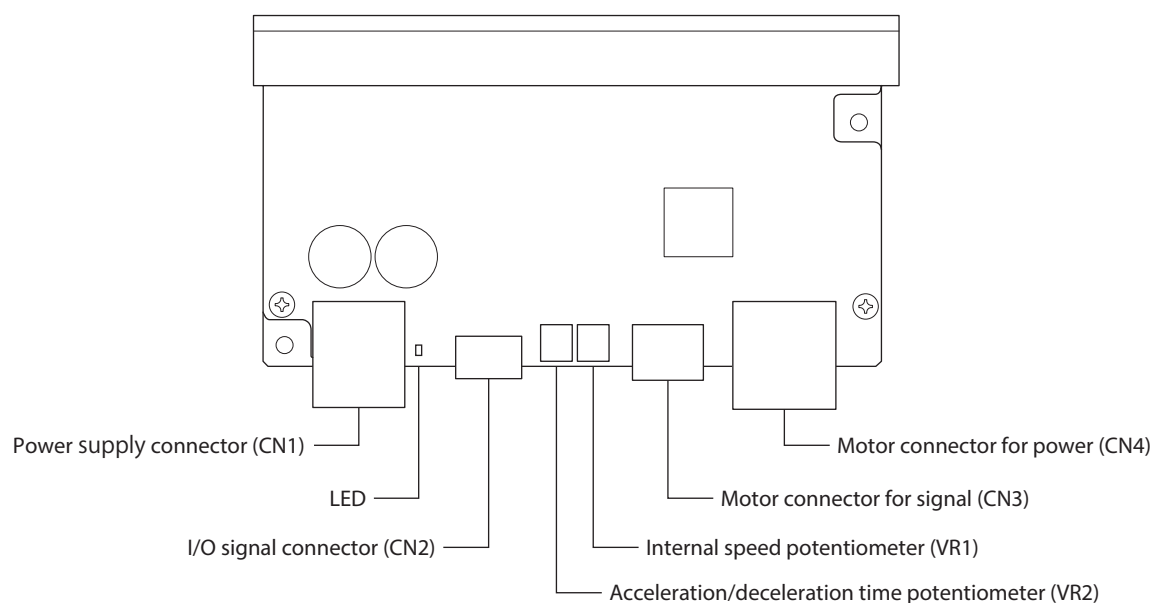

Name	Indication	Description
Power supply connector	CN1	Connects the power supply cable.
I/O signal connector	CN2	Connects the I/O signal cable to connect with an external control device.
Motor connector for signal	CN3	Connects the motor cable.
Motor connector for power	CN4	
LED	POWER/ALARM	Lights up when current is applied. When the protection function has been activated, the cause of the activated protection function is indicated by the number of flashes.
Internal speed potentiometer	VR1	Sets the rotation speed. The speed is set to 0 r/min at time of shipment.
Acceleration/deceleration time potentiometer	VR2	Sets the acceleration time and deceleration time.

5 Installation

5.1 Installation location

The driver is designed and manufactured to be incorporated in equipment.

Install it in a well-ventilated location that provides easy access for inspection. The location must also satisfy the following conditions:

- Inside an enclosure that is installed indoors (provide vent holes)
- Operating ambient temperature: 0 to +50°C [+32 to +122 °F] (non-freezing)
- Operating ambient humidity: 85% or less (non-condensing)
- Area that is free of explosive atmosphere or toxic gas (such as sulfuric gas) or liquid
- Area not exposed to direct sun
- Area free of excessive amount of dust, iron particles or the like
- Area free of excessive salt
- Area not subject to splashing water (rain, water droplets), oil (oil droplets) or other liquids
- Area not subject to continuous vibration or excessive shocks
- Area free of excessive electromagnetic noise (from welders, power machinery, etc.)
- Area free of radioactive materials, magnetic fields or vacuum
- Altitude: Up to 1000 m (3300 ft.) above sea level

5.2 Installing the driver

■ Installation direction

The driver is designed on the basis of heat radiation by air convection and heat conduction to an enclosure.

When installing the driver in an enclosure, be sure to use the mounting holes on the driver, and install it in a horizontal direction.

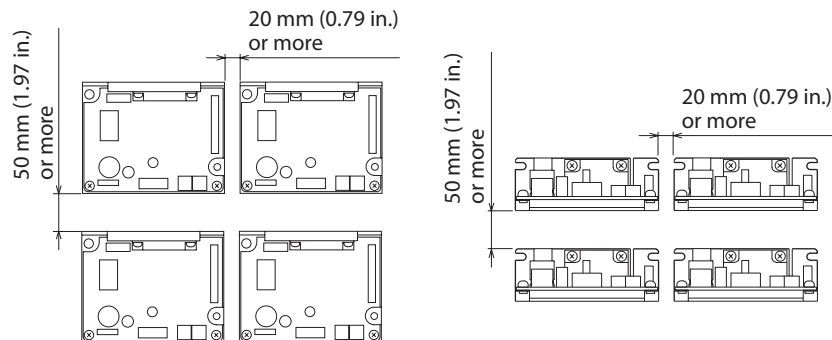

■ Installation method

Install the driver onto an appropriate flat metal plate having excellent vibration resistance and heat conductivity.

Using the mounting holes or notches of the driver, secure it with two screws (M3: not included) so as not to leave a gap between the driver and metal plate.

Note

- Do not install any equipment that generates a large amount of heat or noise near the driver.
- If the ambient temperature of the driver exceeds the upper limit of the operating ambient temperature, reconsider the ventilation condition or forcibly cool the area around the driver using a fan in order to keep within the operating ambient temperature.

6 Connection

This chapter explains how to connect the driver with the motor, power supply cable, and I/O signals.

6.1 Connecting the motor and driver (CN3, CN4)

Insert the motor cable connector into the motor connector (CN3, CN4) on the driver.

When extending the motor cable, use a connection cable (sold separately).

The maximum extension distance including the cable length of the motor itself should be 2 m (6.6 ft.).

Note

- Firmly insert the connector in position. Insecure connector connection may cause malfunction or damage to the motor or driver.
- Be sure to insert and pull out the connector while holding the connectors part. Do not apply any force in a direction other than the direction of inserting and pulling out the connector. Applying improper force may cause damage to the connector and driver.

● CN3 pin assignment

Pin No.	Lead wire color	Lead wire size *
1	Yellow	AWG22 (AWG26)
2	Green	
3	Orange	
4	Red	
5	Brown	

Housing: 51103-0500 (molex)

Terminal: 50351-8000 (molex)

* The parentheses () indicates the electromagnetic brake motor.

● CN4 pin assignment

Pin No.	Lead wire color	Lead wire size
1	Blue	AWG18
2	Purple	
3	Gray	

Housing: 1-178288-3 (TE Connectivity)

Terminal: 1-175196-3 (TE Connectivity)

6.2 Connecting the power supply (CN1)

Insert the power supply cable connector into the power supply connector (CN1) on the driver.

Lead wire size: AWG18 (0.75 mm²)

Note

- When connecting, pay attention to the polarity of the power supply. Connection with incorrect polarity may cause damage to the driver.
- Do not wire the power supply cable of the driver in the same cable duct with other power lines or motor cables.
- When turning on the power again or inserting/pulling out the motor cable connector, turn off the power and wait for at least 5 seconds before doing so.

CN1 pin assignment

Pin No.	Lead wire color	Lead wire size
1	Black	AWG18
2	Red	

Housing: 1-178128-2 (TE Connectivity)

Terminal: 1-175196-3 (TE Connectivity)

Note on power ON/OFF using a mechanical contact

- When turning on or off the power supply using a mechanical contact (breaker, electromagnetic switch, relay, etc.), do so only the positive side (+) of the power supply using the mechanical contact.

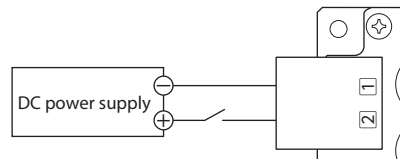

Do not turn on or off the positive side (+) and the negative side (-) of the power supply simultaneously or shut off only the negative side (-) of the power supply. The main circuit and the control circuit in the driver are connected to the same ground. So the input current of the main circuit flows round into the control circuit when the power supply is turned on or off, causing damage to the control circuit or peripheral equipment.

6.3 Connecting the I/O signals (CN2)

Insert the connector of the I/O signal cable into the I/O signal connector (CN2) of the driver.
Lead wire size: AWG26 (0.14 mm²)

CN2 pin assignment

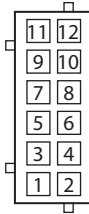

Housing: PHDR-12VS (JST)
Terminal: SPHD-001T-P0.5 (JST)

Pin No.	Lead wire color	Signal name	Description
12	-	-	Not connected.
11	Black	START/STOP	These signals are used to operate the motor. The motor rotates according to the acceleration time when both the START/STOP input and the RUN/BRAKE input are turned ON. If the START/STOP input is turned OFF, the motor stops according to the deceleration time. If the RUN/BRAKE input is turned OFF, the motor stops instantaneously.
10	White	RUN/BRAKE	
9	Gray	CW/CCW	This signal is used to change the motor rotation direction. The motor rotates in the CW direction when this signal is turned ON, and in the CCW direction when it is turned OFF. *
8	Light blue	INT.VR/EXT	When the INT.VR/EXT input is ON, the setting speed of the internal potentiometer (VR1) is enabled. When it is OFF, the setting speed of the external potentiometer or external DC voltage is enabled.
7	Purple	ALARM-RESET	This signal is used to reset the alarm. (The alarm will be reset at the OFF edge of the input.)
6	Blue	VRH	These signals are used when the rotation speed is externally set using an external potentiometer or external DC voltage.
5	Green	VRM	
4	Yellow	VRL	
3	Orange	GND	I/O signals common
2	Red	SPEED	30 pulses are output while the motor output shaft makes one revolution in synchronization with the motor rotation. The pulse width of output pulse signals is 0.3 ms. The motor rotation speed can be calculated using the SPEED-OUT output. Refer to p.17 for details.
1	Brown	ALARM	This is a signal to output an alarm status. It is turned OFF when an alarm is generated. The generated alarm content can be checked by counting the number of times the LED blinks. Refer to p.17 for details.

* The rotation direction varies depending on the gear ratio of gearhead.

6.4 Driver I/O circuit and example connection

Input signal

The driver's signal input is a C-MOS input. The signal status indicates "0 to 0.5 V (L level) when ON," or "4 to 5 V (H level) when OFF."

- External control device output is a 5 V C-MOS output

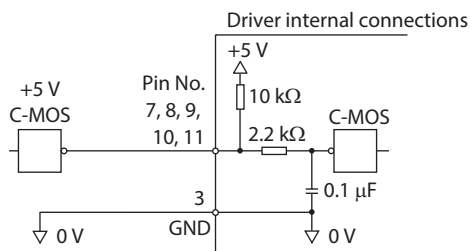

- External control device output is an open-collector output

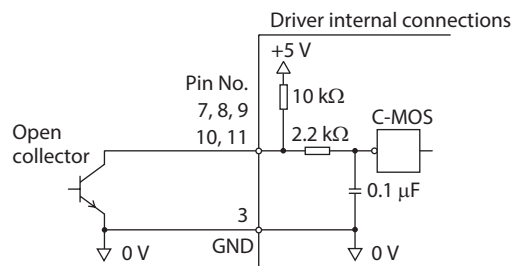

- Switch connection

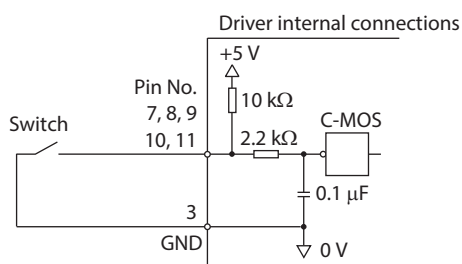

Output signal

The driver's signal output is a transistor open-collector output. The signal status does not indicate the voltage level of the signal, but it indicates "ON (energized)" or "OFF (not energized)" of the internal transistor.

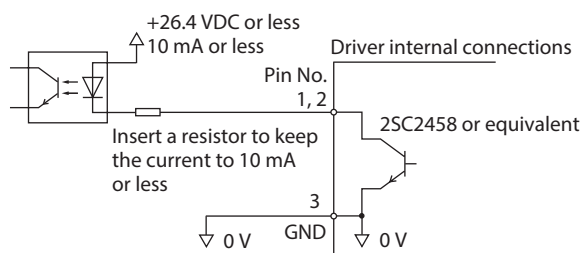

Note

When connecting a relay (inductive load), etc., to detect alarm outputs, provide a fly-back voltage control measure based on diode, etc., for the inductive load. Or use a relay with built-in flywheel diode. If the driver is used without connecting a current-limiting resistor, it will be damaged.

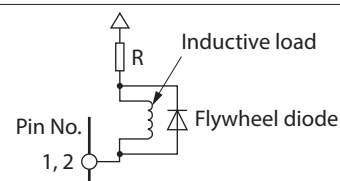

6.5 Grounding

The wire used to ground the motor and driver must be as thick and short to the grounding point as possible so that no potential difference is generated. Choose a large, thick and uniformly conductive surface for the grounding point.

● Grounding the motor

Connect the grounding wire along with a set screw to the grounding point, using a shakeproof washer.

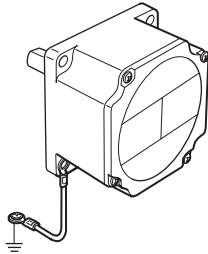

● Grounding the driver

Install the driver to a metal surface that has grounded.

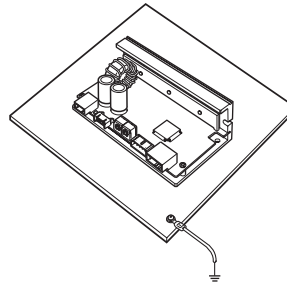

6.6 Connection diagram

The figure shows an example when an external potentiometer is connected.

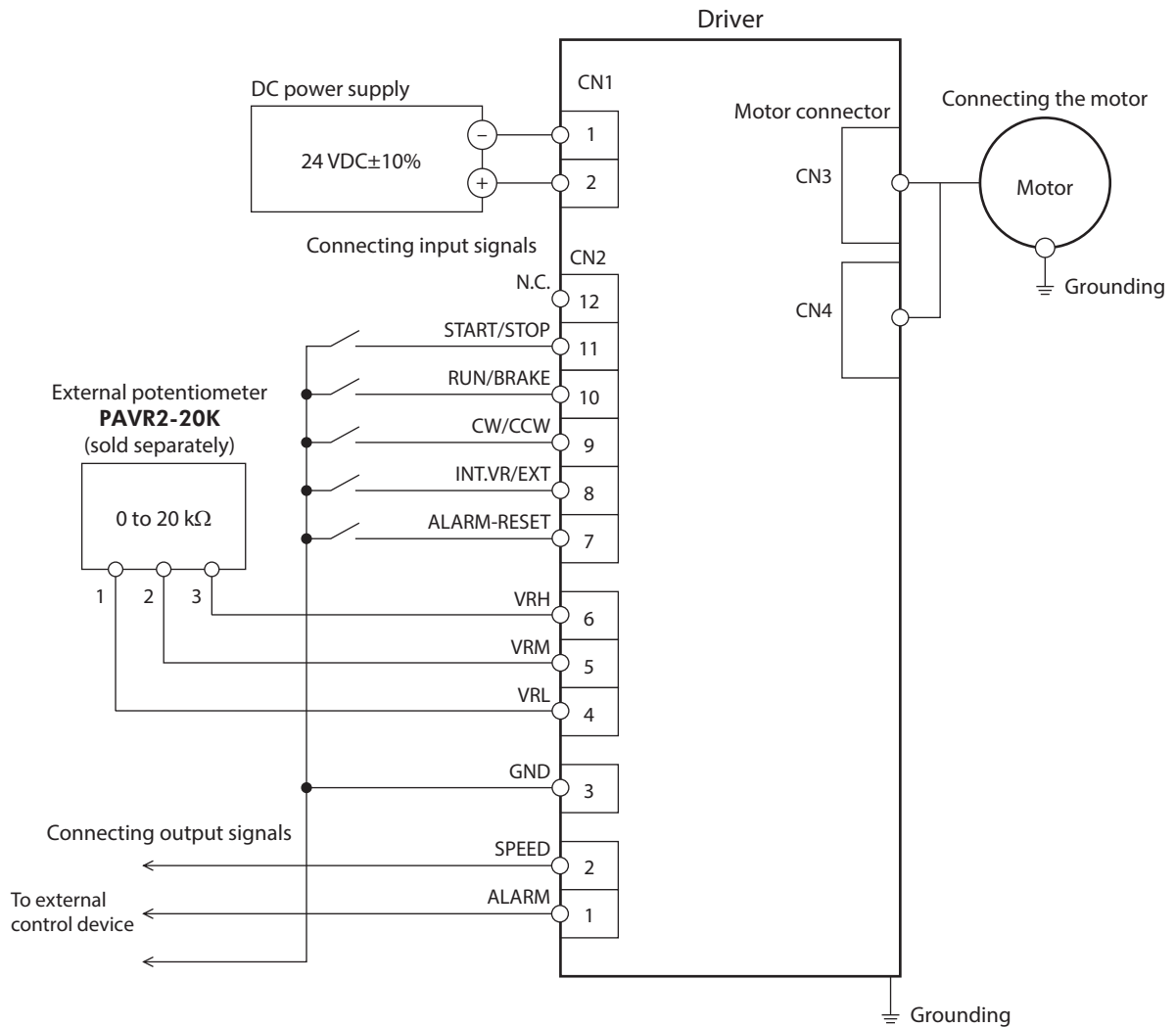

Note Insulate unused lead wires which are on the opposite side to the connector of the I/O signal cable to prevent them from contacting other devices, or connect them to 5 VDC or the signal ground (GND) of your external control device according to usage of signals.

6.7 Noise measures

There are two types of electrical noises: One is a noise to invade into the driver from the outside and cause the driver malfunction, and the other is a noise to emit from the driver and cause peripheral equipments malfunction. For the noise that is invaded from the outside, take measures to prevent the driver malfunction. It is needed to take adequate measures because signal lines are very likely to be affected by the noise. For the noise that is emitted from the driver, take measures to suppress it.

Measures against electrical noise

There are the following three methods mainly to take measures against the electrical noise.

- Noise suppression
 - When relays or electromagnetic switches are used, use noise filters or CR circuits to suppress surge generated by them.
 - Use a connection cable (sold separately) when extending the wiring distance between the motor and the driver. This is effective in suppressing the electrical noise emitted from the motor.
 - Cover the driver by a metal plate such as aluminum. This is effective in shielding the electrical noise emitted from the driver.
- Prevention of noise propagation
 - Separate power lines such as motor cable and power supply cable from signal lines for a distance of 100 mm (3.94 in.) or more, and also do not bundle them or wire them in parallel. If the power lines must cross over the signal lines, wire them at right angles.
 - Use a cable of AWG26 (0.14 mm²) or thicker for the signal cable of the driver, and keep the wiring distance of 3 m (9.8 ft.) or less.
 - For more effective elimination of noise, use shielded I/O signal cable, or attach ferrite cores if non-shielded cables are used.
 - Keep cables as short as possible without coiling and bundling extra lengths.
 - To ground a shielded cable, use a metal cable clamp that can maintain contact with the entire circumference of the shielded cable, and ground as near the product as possible.
- Grounding multiple points will increase effect to block electrical noise because impedance on the grounding points is decreased. However, ground them so that a potential difference does not occur among the grounding points.
- Suppression of effect by noise propagation
 - Loop the noise propagated cable around a ferrite core. Doing so will prevent the propagated noise invades into the driver or emits from the driver. The frequency band in which an effect by the ferrite core can be seen is generally 1 MHz or more. Check the frequency characteristics of the ferrite core used. When increasing the effect of noise attenuation by the ferrite core, loop the cable a lot.

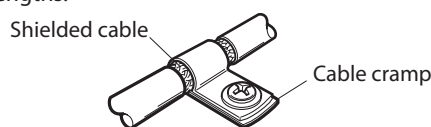

6.8 Conformity to the EMC Directive

Effective measures must be taken against the EMI that the motor and driver may give to adjacent control-system equipment, as well as the EMS of the motor and driver itself, in order to prevent a serious functional impediment in the machinery. The use of the following installation and wiring methods will enable the motor and driver to be compliant with the EMC directive.

Oriental Motor conducts EMC measurements on its motors and drivers in accordance with "Example of installation and wiring" shown on the next page. The user is responsible for ensuring the machine's compliance with the EMC Directive, based on the installation and wiring explained below.



CAUTION

This equipment is not intended for use in residential environments nor for use on a low-voltage public network supplied in residential premises, and it may not provide adequate protection to radio reception interference in such environments.

■ About power supply

The **BLH** Series is a product of DC power supply input. Use a DC power supply (such as a switching power supply) that optimally conforms to the EMC Directive.

■ Connecting the motor cable

When extending the motor cable, use an connection cable (sold separately). The maximum extension distance including the cable length of the motor itself should be 2 m (6.6 ft.).

■ Ferrite core

Use a ferrite core to suppress effect by noise propagation.

Use 7427122 (Würth Elektronik GmbH & Co.KG), ZCAT3035-1330 (TDK Corporation) or equivalent ferrite cores.

Install the ferrite core as close as possible to the driver.

■ Wiring the I/O signal cable

Refer to "Prevention of noise propagation" on p.13.

■ Notes about installation and wiring

- Connect the motor, driver and other peripheral control equipment directly to the grounding point so as to prevent a potential difference from developing between grounds.
- When relays or electromagnetic switches are used together with the system, use noise filters and CR circuits to suppress surges generated by them.
- Cable as short as possible without coiling and bundling extra lengths.
- Separate power lines such as motor cable and power supply cable from signal lines, and wire them apart as much as possible [example: about 100 to 200 mm (3.94 to 7.87 in.)]. If the power lines must cross over the signal lines, wire them at right angles.

■ Example of installation and wiring

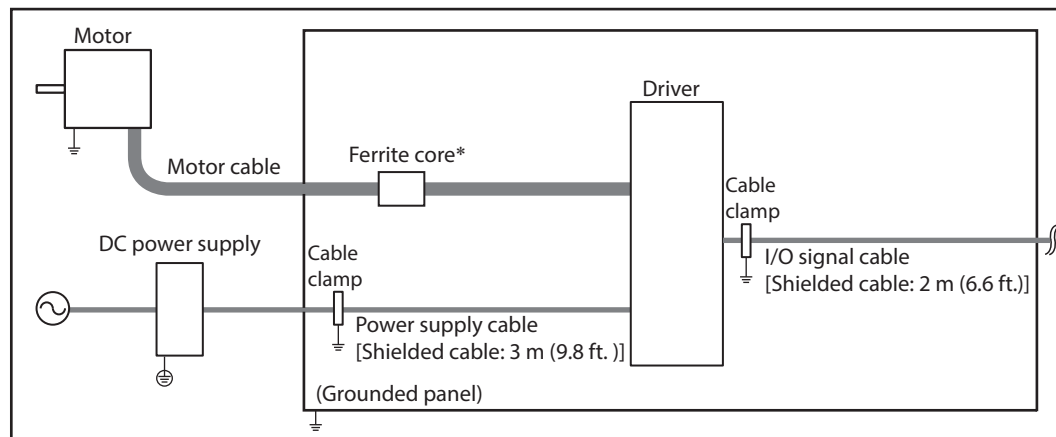

* When suppressing effect by noise propagation, use a ferrite core.

■ Precautions about static electricity

Static electricity may cause the driver to malfunction or suffer damage. Be careful when handling the driver while the power is supplied.

Always use an insulated screwdriver to adjust the internal potentiometers of the driver.



Do not approach or touch the driver while the power is supplied.

7 Operation

7.1 Input signals and output signals

CAUTION Do not perform the motor's starting and stopping operations by turning the power supply on and off. Perform them by inputting START/STOP and RUN/BRAKE. This may cause injury or damage to the equipment.

- Note**
- The input signals (START/STOP, RUN/BRAKE, CW/CCW, INT.VR/ EXT, ALARM-RESET) must be ON for at least 10 ms. It may cause malfunction of the motor.
 - Do not operate (switch the ON/OFF status) of the START/STOP input, RUN/BRAKE input, CW/CCW input and INT.VR/EXT input simultaneously. After switching a given input, wait at least 10 ms before switching another input.
 - The motor temperature rise is sharper as friction load and inertial load are higher, and start, instantaneous stop and reversing frequency is higher. It must be used when motor case temperature does not exceed 90 °C (194 °F), and driver heat radiation plate temperature does not exceed 90 °C (194 °F).

START/STOP input and RUN/BRAKE input

To switch between motor running and instantaneous stop (or stop), use START/STOP input, RUN/BRAKE input.

	START/STOP input	RUN/BRAKE input	Motor operation
Signal level	ON	ON	Running*1
	ON	OFF	Instantaneous stop
	OFF	ON	Stop*2

- *1 The motor speed can be made to reach the set speed by any one of the internal potentiometer, external potentiometer or external DC voltage. The motor accelerates over the time set by the acceleration/deceleration time potentiometer.
- *2 The motor decelerates over the time set by the acceleration/deceleration time potentiometer.

- Note**
- The BRAKE takes precedence when START/STOP and RUN/BRAKE inputs are turned off simultaneously.
 - The actual acceleration/deceleration time is affected by the use condition, load inertia, load torque and other conditions implemented by the user.

START/STOP input

START is selected when the input is ON, and motor starts running. The motor accelerates over the time set by the acceleration/deceleration time potentiometer.

STOP is selected when the input is OFF, and motor stops. The motor decelerates over the time set by the acceleration/deceleration time potentiometer.

RUN/BRAKE input

RUN is selected when the input is ON, and motor starts running.

BRAKE is selected when the input is OFF, and motor stops instantaneously.

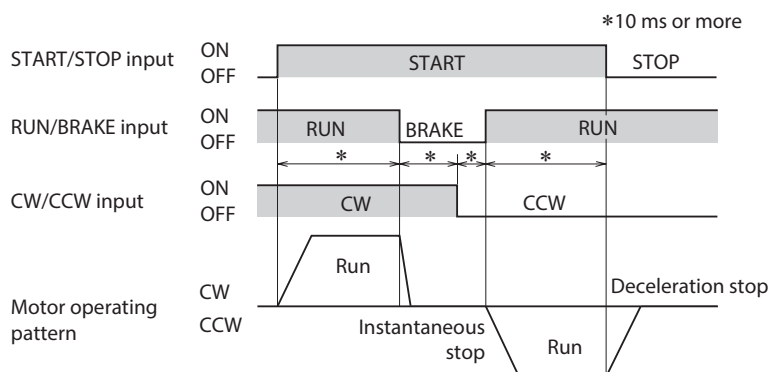

- Note** Once the motor stops, the output shaft will become free.

■ CW/CCW input

CW is selected when the input is ON. CCW is selected when the input is OFF.
The drive direction is the same as that of the motor output shaft when viewed from the motor output side.

Note Depending on the gearhead ratio, the drive direction of the gear output shaft may be opposite of that of the motor. Check the operating manual of the motor for the rotation direction of the gearhead output shaft.

■ INT.VR/EXT input

INT.VR is selected when the input is ON, and the setting speed of internal potentiometer is enabled. EXT is selected when the input is OFF, and the setting speed of external potentiometer or external DC voltage is enabled. Switching this signal allows combined use of the external potentiometer or external DC voltage or two-speed switching operation. When the internal potentiometer is not used, there is no necessity even if there is no connection.

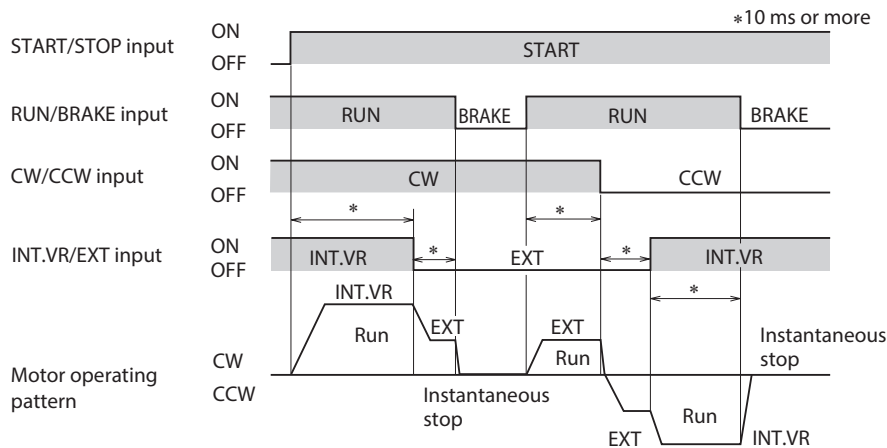

■ ALARM-RESET input

Use the ALARM-RESET input if you need to move the motor to a specified position or the mechanical home position after the motor has stopped in the middle of operation due to an actuation of the driver's protective function (ALARM output: OFF).

After the motor has been moved, check and remove the cause of the alarm and then reset the alarm. The ALARM can also be reset when the power supply is cycled.

For ALARM conditions, see p.17.

When the motor is stopped, turn on this signal; then turn it off. This will allow ALARM to be reset.

Before inputting the ALARM-RESET, reset either the START/STOP or RUN/BRAKE input to the OFF. If both are ON, ALARM-RESET input will not be accepted.

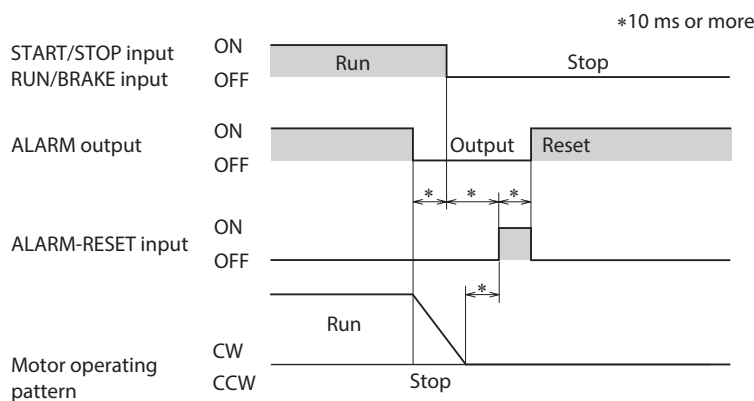

- Note**
- The START/STOP input and RUN/BRAKE input are not accepted until the ALARM output is reset.
 - Turn ON the ALARM-RESET input after confirming that the motor (gearhead) output shaft has stopped completely.

■ SPEED output

Pulse signals (pulse width: 0.3 ms) of 30 pulses per revolution of the motor output shaft are output in synchronism with the motor drive.

Motor speed can be calculated by measuring the SPEED output frequency.

$$\text{Motor speed}^*[\text{r/min}] = \frac{\text{SPEED output frequency} [\text{Hz}]}{30} \times 60$$

$$\text{SPEED output frequency} = \frac{1}{T}$$

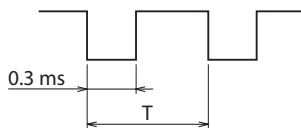

* The speed of the gear output shaft of a combination type is obtained by dividing the motor speed by the gear ratio.

■ ALARM output

The protection function of the driver activates in following cases, and the ALARM output is turned OFF, thereby stopping the motor.

In this case, you can check the contents of the protection function, which was operating by the number of LED flashes.

The LED lights for 0.3 s and goes off for 0.3 s. After a specified number of flashes, flashing is performed at intervals of 1.5 s.

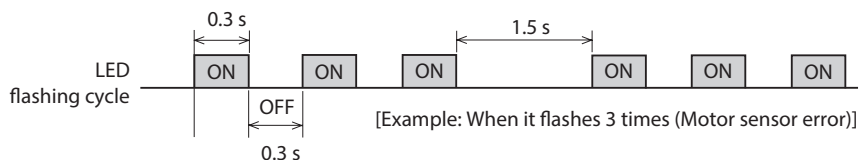

WARNING

When the driver's protection function is triggered, first remove the cause and then clear the protection function. Continuing the operation without determining the cause of the problem may cause malfunction of the motor, leading to injury or damage to equipment.

Protection function	Number of ALARM LED flashes	Assumed causes
Overload protection function	2 times	<ul style="list-style-type: none"> When a load in excess of the rated torque was applied to the motor for about 5 s or more. When the motor running/instantaneous stop and drive direction switching was repeated in a short time.
Motor sensor error	3 times	<ul style="list-style-type: none"> When the sensor cable in the motor cable was disconnected.
Overvoltage protection function	4 times	<ul style="list-style-type: none"> When the motor was used in an elevating/lowering application or with a load in excess of the permissible load inertia. When voltage applied to the driver has exceeded the voltage setting (24 VDC) by 25% or greater.
Insufficient voltage protection function	5 times	<ul style="list-style-type: none"> When voltage applied to the driver was less than the voltage setting (24 VDC) by 25% or greater.
Overspeed protection function	6 times	<ul style="list-style-type: none"> When motor speed has reached an excess of 3500 r/min.

If the connection example on p.11 is followed, the ALARM output should remain ON while the driver is normal and turn OFF if an alarm has occurred.

If the ALARM output has turned OFF, stop the motor operation and then remove the cause that triggered the applicable protective function by referring to the number of times the LED flashes. After remove the cause for activation of the protection function, reset the ALARM (for ALARM-RESET input, see p.16).



The START/STOP input and RUN/BRAKE input are not accepted when the ALARM is OFF.

Examples of operation patterns

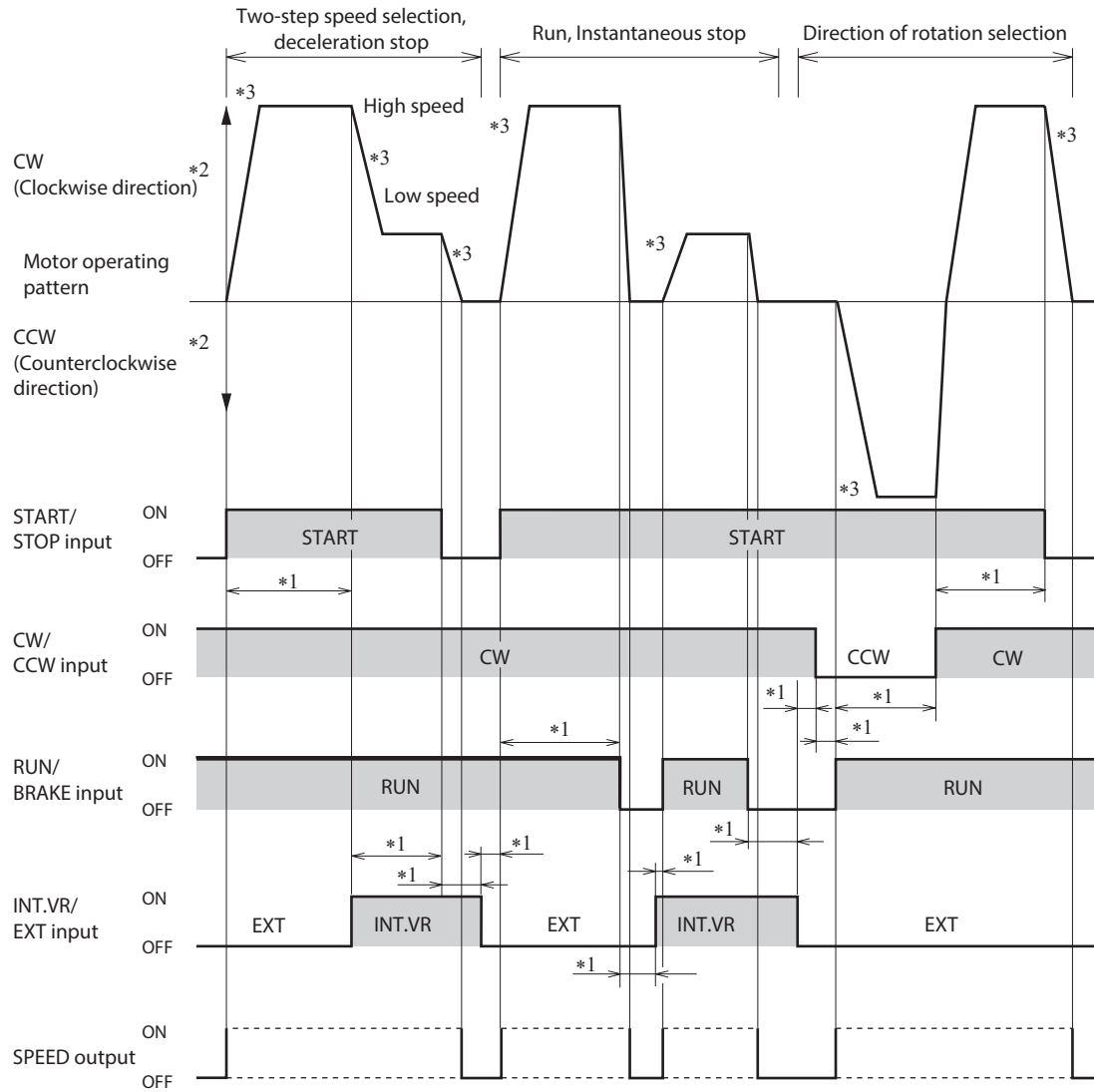

- *1 10 ms or more
- *2 The direction of rotation is the case of the motor alone. It depends on the gear ratio.
- *3 The motor starts and stops over the time set by the acceleration/deceleration time potentiometer.

Note To surely recognize the input signal, ensure the ON time and OFF time of each input signal for at least 10 ms.

7.2 Rotation direction of the motor output shaft

The rotation direction of the motor output shaft represents the direction when viewed from the motor output shaft.

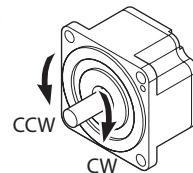

Rotation direction of the gearhead output shaft

The rotation direction of the gearhead output shaft varies depending on the type or the gear ratio of the gearhead. Check the operating manual of the motor for the rotation direction of the gearhead output shaft.

7.3 Setting the running speed

Set the operating speed of the motor using the internal speed potentiometer, external speed potentiometer or external DC voltage. The motor speed range is from 100 to 3000 r/min for the case of the motor alone.

Two running speeds can be set by combining the internal potentiometer and external potentiometer, or the internal potentiometer and external DC voltage.

■ Setting by internal potentiometer

This potentiometer is used when running speed setting is not frequently changed, or when twostep speed switching is performed in combination with external speed setting.

Adjust the potentiometer using an insulated screwdriver. Clockwise rotation will increase the set speed. The speed is set to 0 r/min at time of shipment.

When the motor is driven at the speed set by the internal potentiometer, turn on the INT.VR/EXT input.

When you want to use only the internal speed setting potentiometer to set the operation speed, you do not have to connect the VRH, VRM and VRL.

■ Setting by external potentiometer

This potentiometer is used when the speed is set away from the driver or when two-step speed switching is performed in combination with the internal potentiometer.

Use the accessory **PAVR2-20K** as the external potentiometer.

Clockwise rotation will increase the set speed.

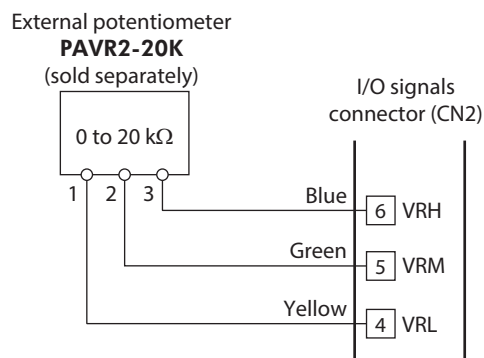
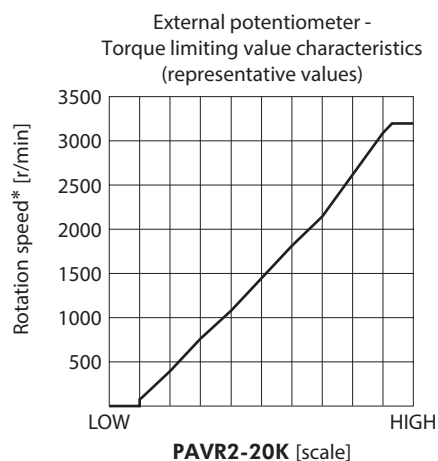

* Indicates the speed of the motor alone. The speed of the gear output shaft of a geared type or combination type is obtained by dividing the motor speed by the gear ratio.

To drive the motor at the speed set on the external potentiometer, turn off the INT.VR/EXT input.

- To set the running speed only by the external potentiometer, there is no problem if the INT.VR/EXT input is not connected.
- To perform operation by switching the motor running speed, use the INT.VR/EXT to switch the external potentiometer and internal potentiometer.



To use a shielded cable for connection with the external potentiometer, connection should be made close to the I/O signals cable connector. Connect the shielded wire to the pin No.3 GND.

■ Setting by external DC voltage

External DC voltage is used when the speed is set by D/A output from an external control device such as a programmable controller, or when the speed is switched over two levels during operation in combination with the internal speed potentiometer.

For external DC voltage, use DC power supply (0 to 5 VDC, 1 mA or more) where the primary and secondary sides are provided with reinforced insulation.

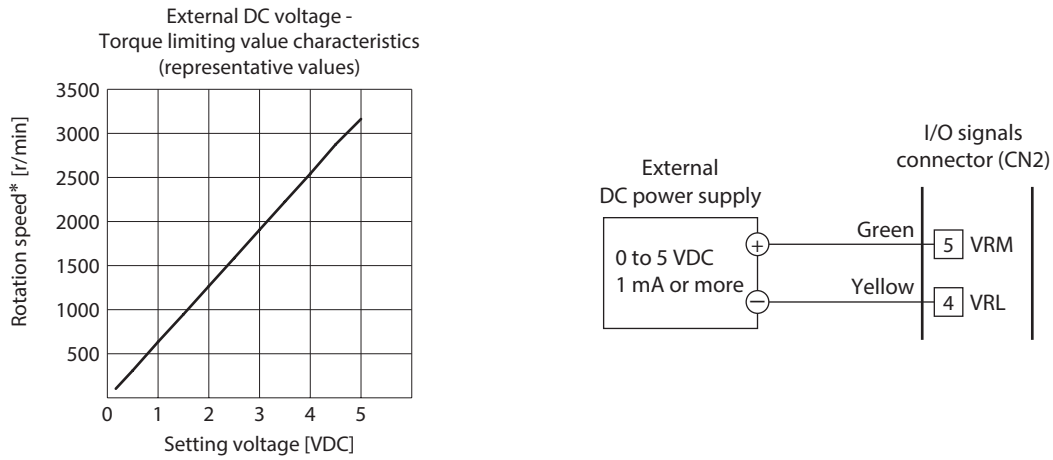

* Indicates the speed of the motor alone. The speed of the gear output shaft of a geared type or combination type is obtained by dividing the motor speed by the gear ratio.

To drive the motor set at the external DC voltage, turn off the INT.VR/EXT input.

- To set the running speed only by the external speed setter, there is no problem if the INT.VR/ EXT input is not connected.
- To perform operation by switching the motor running speed, use the INT.VR/EXT to switch the external DC voltage and internal potentiometer.



- The external DC power supply voltage must not exceed 5 VDC. Otherwise, the driver may be damaged.
- When connecting the external DC power supply, sufficient care must be taken not to mistake power polarity. Connection with incorrect polarity may damage the driver.
- To use a shielded cable for connection with the external DC power supply, connection should be made close to the I/O signals cable connector. Connect the shielded wire to the pin No.3 GND.

7.4 Setting the acceleration time and deceleration time

Set the acceleration time and deceleration time using the acceleration/deceleration time potentiometer (p.7). The acceleration time and deceleration time are always identical.

Adjust the potentiometer using an insulated screwdriver. Turning the potentiometer clockwise increases the time. You can set a desired time in a range of 0.5 to 10 seconds. The minimum time is set at time of shipment.

“Acceleration time” indicates the time required by the motor to reach the rated speed from a stopped condition.

“Deceleration time” indicates the time required by the motor to stop from the rated speed.

With the it indicates the time needed by the motor to reach 2500 r/min from a stopped condition or to stop from 2500 r/min (under no load). The actual acceleration/deceleration time is affected by the use condition, load inertia, load torque and other conditions implemented by the user.

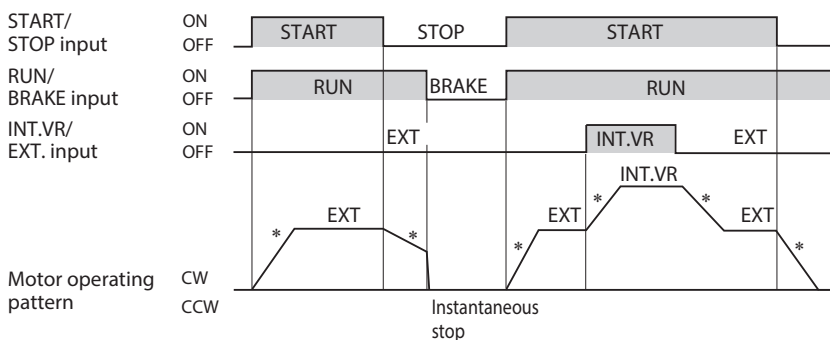

* The motor starts and stops over the time set by the acceleration/deceleration time potentiometer.

7.5 Multi-motor control

If two or more motors are to be operated at the same speed, they can be controlled from the DC power supply or external potentiometer.

Use external DC power supply

- Use a DC power supply whose current capacity is at least the value calculated by the formula below:
Current capacity when N drivers are connected: $I = 1 \times N$ (mA)
Example: If two drivers are connected, the current capacity should be at least 2 mA.
- All I/O signals other than the one used for speed setting should be connected to each driver.
- If multiple motors are used with speed differences among them, make the following adjustments:
First motor: Connect a resistor of 1.5 k Ω , 1/4 W to the driver's M terminal.
Second and subsequent motors: Connect a variable resistor (VRn) of 5 k Ω , 1/4 W to the applicable driver's M terminal.

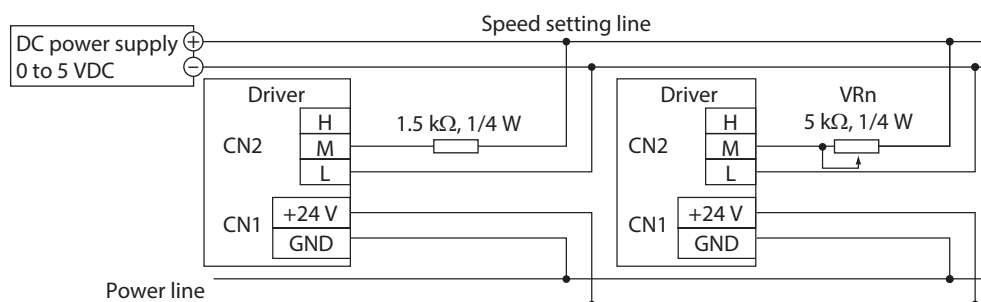

Use an external potentiometer

Use common lines for the power supply and speed control and set the speed using VRx, as shown below.

- Obtain the resistance for the external speed potentiometer as follows:
Resistance when N drivers are connected: $VRx = 20/N$ (k Ω), $N/4$ (W)
Example: If two drivers are connected, the current capacity should be 10 k Ω , 1/2 W.
- All I/O signals other than the one used for speed setting should be connected to each driver.
- If multiple motors are used with speed differences among them, make the following adjustments:
First motor: Connect a resistor of 1.5 k Ω , 1/4 W to the driver's M terminal.
Second and subsequent motors: Connect a variable resistor (VRn) of 5 k Ω , 1/4 W to the applicable driver's M terminal.
- Keep the number of drivers to five or less in parallel operation using an external potentiometer.

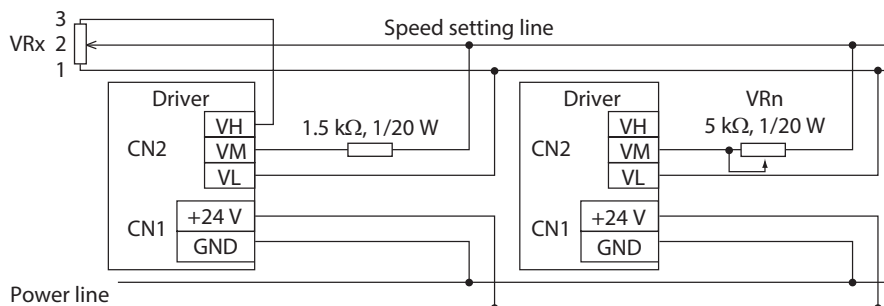

8 Maintenance and inspection

8.1 Inspection

It is recommended that periodic inspections would be conducted for the items listed below after each operation of the motor.

If an abnormal condition is noted, discontinue any use and contact your nearest Oriental Motor sales office.



- Do not conduct the insulation resistance measurement or dielectric strength test with the motor and driver connected. Doing so may cause damage to the product.
- The driver uses semiconductor elements, so be extremely careful when handling them. Static electricity may damage the driver.

■ Inspection item

- Check if any of the mounting screws of the motor and gearhead is loose.
- Check if the bearing part (ball bearings) of the motor generates unusual noises.
- Check if the bearing part (ball bearings) or gear meshing part of the gearhead generates unusual noises.
- Check if the output shaft of the motor and gearhead and a load shaft are out of alignment.
- Check if a damage or stress is applied on the cable or the connection part between the cable and driver is loose.
- Check if dust is deposited on the driver.

8.2 Warranty

Check on the Oriental Motor Website for the product warranty.

8.3 Disposal

Dispose the product correctly in accordance with laws and regulations, or instructions of local governments.

9 Troubleshooting

The motor or driver may not operate properly if the rotation speed is wrongly set or the connection is wrong. If the motor cannot operate properly, refer to the contents provided in this chapter and take appropriate action. If the problem persists, contact your nearest Oriental Motor sales office.

Note Check the alarm contents when an alarm is generated.

Phenomenon	Estimated cause	Measure
The motor fails to turn.	Either START/STOP input or RUN/BRAKE input is not set to the ON.	Make sure that both START/STOP input or RUN/BRAKE input are set to the ON.
	The internal potentiometer is not adjusted.	Turn the internal potentiometer slightly in the clockwise direction. The speed is set to 0 r/min at time of shipment.
	When the internal potentiometer is used, INT.VR/EXT input is not set to the ON.	Set the INT.VR/EXT input to the ON. When the INT.VR/EXT input is set to the ON, the internal potentiometer is selected.
	The external potentiometer contact is faulty.	Check for connection of the external potentiometer.
	When the external potentiometer is used, INT.VR/EXT input is not set to the OFF.	Set the INT.VR/EXT input to the OFF. When the INT.VR/EXT input is set to the OFF, the external potentiometer is selected.
	The external DC voltage contact is faulty.	Check for connection of the external DC voltage.
	When an external DC voltage is used, INT.VR/EXT input is not set to the OFF.	Set the INT.VR/EXT input to the OFF. When the INT.VR/EXT input is set to the OFF, external DC voltage is selected.
<ul style="list-style-type: none"> The motor fails to turn. The motor stops halfway. 	Protection function has activated.	Check the LED flashings. See p.17 and check the causes in conformity to the activated protection function. Take the appropriate measures.
The motor is driven opposite of the specified direction.	Incorrect CW/CCW input or faulty connection.	The motors driven in the CW direction when the CW/CCW input is set to the ON. CCW direction when the CW/CCW input is set to the OFF.
	Speed reduction ratios 30:1, 50:1 and 100:1 are used in the combination type.	When these speed reduction ratios are used, drive direction is opposite to that of the motor. Reverse the CW/CCW input operation.
	A combination type hollow shaft gearhead is used.	With a combination type hollow shaft flat gearhead, the rotating direction will vary depending on whether the motor unit is viewed from the front or rear of the gearhead.
<ul style="list-style-type: none"> The motor does not run. Motor vibration too great. 	The motor (gearhead) output shaft and load shaft are not aligned with each other.	Make sure that the motor (gearhead) output shaft and load shaft are connected in an appropriate manner.
	Affected by noise.	Check for running only with the motor, driver and external potentiometer required for running. If noise influence has been confirmed, take the appropriate measures such as separation from noise generating source, re-connection of wiring, replacement of the signal cable by a shielded cable, and installation of a ferrite core.
The motor fails to stop instantaneously.	The motor is stopped by START/STOP input.	Stop the motor by RUN/BRAKE input.
	Load inertia may be excessive.	For this check, increase the frictional load or reduce the load inertia.
	The deceleration time is too long.	Check the setting of the acceleration/ deceleration time potentiometer.

10 Specifications

10.1 Specifications

Values in the rated torque, peak torque, rated rotation speed, and speed control range represent those in a state where the gearhead is not combined. Refer to the operating manual of the motor for the motor model name.

Model	Motor	BLHM5100KC-□□* BLHM5100KCM-□□
	Driver	BLHD100K
Rated output power (Continuous)		100 W
Power supply input	Rated voltage	24 VDC
	Permissible voltage range	-10 to +10%
	Rated input current	6.0 A
	Maximum input current	9.8 A
Rated torque		0.4 N·m (56 oz-in)
Peak torque		0.5 N·m (71 oz-in)
Rated rotation speed		2500 r/min
Speed control range		100 to 3000 r/min

* For the lead wire type, "KC" of the motor model are replaced by "K".
Check on the Oriental Motor Website for the product specifications.

10.2 General specifications

Operating environment	Ambient temperature	Driver: 0 to +50 °C [+32 to +122 °F] (non-freezing)
	Ambient humidity	85% or less (non-condensing)
	Altitude	Up to 1000 m (3300 ft.) above sea level
	Surrounding atmosphere	No corrosive gas, dust, water or oil. Cannot be used in radioactive materials, magnetic field, vacuum or other special environment. (For details about installation locations, refer to p.8.)
	Vibration	Not subject to continuous vibrations or excessive impact. In conformance with JIS C 60068-2-6 "Sine-wave vibration test method" Frequency range: 10 to 55 Hz Pulsating amplitude: 0.15 mm (0.006 in.) Sweep direction: 3 directions (X, Y, Z) Number of sweeps: 20 times
Storage environment	Ambient temperature	Driver: -25 to +70 °C [-13 to +158 °F] (non-freezing)
Shipping environment	Ambient humidity	85% or less (non-condensing)
	Altitude	Up to 3000 m (10000 ft.) above sea level
	Surrounding atmosphere	No corrosive gas, dust, water or oil. Cannot be used in radioactive materials, magnetic field, vacuum or other special environment.
Degree of protection		IP00

10.3 Dimension

Mass: 0.3 kg (0.66 lb.)

[Unit: mm (in.)]

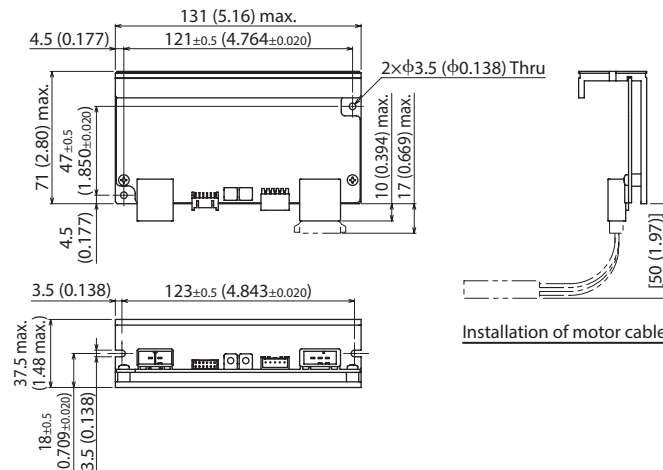

11 Regulations and standards

11.1 UL Standards and CSA Standards

This product is recognized by UL under the UL and CSA standards.

11.2 CE Marking

This product is affixed with the marks under the following directives.

■ EMC Directive

Refer to "6.8 Conformity to the EMC Directive" on p.13 for details about conformity.

11.3 RoHS Directive

This product does not contain the substances exceeding the restriction values.

11.4 Republic of Korea, Radio Waves Act

This product is affixed with the KC Mark under the Radio Waves Act, the Republic of Korea.

- Unauthorized reproduction or copying of all or part of this manual is prohibited.
If a new copy is required to replace an original manual that has been damaged or lost, please contact your nearest Oriental Motor branch or sales office.
- Oriental Motor shall not be liable whatsoever for any problems relating to industrial property rights arising from use of any information, circuit, equipment or device provided or referenced in this manual.
- Characteristics, specifications and dimensions are subject to change without notice.
- While we make every effort to offer accurate information in the manual, we welcome your input. Should you find unclear descriptions, errors or omissions, please contact the nearest office.
- **Orientalmotor** is a registered trademark or trademark of Oriental Motor Co., Ltd., in Japan and other countries.
Other product names and company names mentioned in this manual may be registered trademarks or trademarks of their respective companies and are hereby acknowledged. The third-party products mentioned in this manual are recommended products, and references to their names shall not be construed as any form of performance guarantee. Oriental Motor is not liable whatsoever for the performance of these third-party products.

© Copyright ORIENTAL MOTOR CO., LTD. 2019

Published in April 2022

- Please contact your nearest Oriental Motor office for further information.

ORIENTAL MOTOR U.S.A. CORP.
Technical Support Tel:800-468-3982
8:30am EST to 5:00pm PST (M-F)
www.orientalmotor.com

ORIENTAL MOTOR (EUROPA) GmbH
Schiessstraße 44, 40549 Düsseldorf, Germany
Technical Support Tel:00 800/22 55 66 22
www.orientalmotor.de

ORIENTAL MOTOR (UK) LTD.
Unit 5 Faraday Office Park, Rankine Road,
Basingstoke, Hampshire RG24 8QB UK
Tel:+44-1256347090
www.oriental-motor.co.uk

ORIENTAL MOTOR (FRANCE) SARL
Tel:+33-1 47 86 97 50
www.orientalmotor.fr

ORIENTAL MOTOR ITALIA s.r.l.
Tel:+39-02-93906347
www.orientalmotor.it

ORIENTAL MOTOR ASIA PACIFIC PTE. LTD.
Singapore
Tel:1800-842-0280
www.orientalmotor.com.sg

ORIENTAL MOTOR (MALAYSIA) SDN. BHD.
Tel:1800-806-161
www.orientalmotor.com.my

ORIENTAL MOTOR (THAILAND) CO., LTD.
Tel:1800-888-881
www.orientalmotor.co.th

ORIENTAL MOTOR (INDIA) PVT. LTD.
Tel:1800-120-1995 (For English)
1800-121-4149 (For Hindi)
www.orientalmotor.co.in

TAIWAN ORIENTAL MOTOR CO., LTD.
Tel:0800-060708
www.orientalmotor.com.tw

SHANGHAI ORIENTAL MOTOR CO., LTD.
Tel:400-820-6516
www.orientalmotor.com.cn

INA ORIENTAL MOTOR CO., LTD.
Korea
Tel:080-777-2042
www.inaom.co.kr

ORIENTAL MOTOR CO., LTD.
4-8-1 Higashiueno, Taito-ku, Tokyo
110-8536 Japan
Tel:+81-3-6744-0361
www.orientalmotor.co.jp