

Servo Motor

AZX Series / Motorized Actuator equipped with AZX Series EtherCAT Compatible Driver

OPERATING MANUAL Software Edition

Introduction

Before starting operation

I/O signals

EtherCAT communication

Object list

Troubleshooting

Extended function

Thank you for purchasing an Oriental Motor product.

This Operating Manual describes product handling procedures and safety precautions.

- Please read it thoroughly to ensure safe operation.
- Always keep the manual where it is readily available.

1 Introduction

1	Introduction	6
1-1	Before using the product	6
1-2	Related operating manuals	6
1-3	How to use operating manuals	6
1-4	Screen display of MEXE02 software	7
2	Overview of the product	8
3	Safety precautions	9
3-1	Graphical symbols on the driver's front panel	10
3-2	Description of warning	11
4	Precautions for use	12

2 Before starting operation

1	Operation preparation flow	14
2	Copy the ABZO information (fixed value) to the driver	15
3	Setting of resolution	16
4	Home setting	18
5	Backup of data	19

3 I/O signals

1	Overview of I/O signals	22
1-1	Overview of input signals	22
1-2	Overview of output signals	24
1-3	Setting contents of input signals and output signals	25
2	Signals list	30
2-1	Input signals list	30
2-2	Output signals list	31
3	Signal type	34
3-1	Direct I/O	34
3-2	Remote I/O	38
4	Input signals	40
4-1	Operation control	40
4-2	Position coordinate management	47
4-3	Management of driver	48
5	Output signals	49
5-1	Management of driver	49
5-2	Management of operation	50
5-3	Response outputs	57
6	Timing chart	58

4 EtherCAT communication

1	Guidance	63
2	Communication specifications	65
2-1	EtherCAT communication interface.....	65
2-2	CiA402 drive profile.....	65
2-3	EtherCAT State Machine (ESM).....	66
2-4	Process Data Objects (PDO).....	66
2-5	Service Data Objects (SDO).....	69
2-6	Synchronous mode of EtherCAT.....	69
2-7	Distributed Clocks.....	70
2-8	Emergency message.....	70
3	Drive profile	71
3-1	Drive state machine.....	71
3-2	Operation modes.....	74
3-3	Cyclic synchronous position mode (CSP).....	74
3-4	Profile position mode (PP).....	76
3-5	Cyclic synchronous velocity mode (CSV).....	87
3-6	Profile velocity mode (PV).....	89
3-7	Homing mode (HM).....	91
4	Functions	104
4-1	Touch probe.....	104
4-2	Resolution.....	107
4-3	Wrap function.....	108
4-4	Maintenance commands.....	108
4-5	Assignment of I/O functions.....	109
5	Coordinates management	119
5-1	Overview of coordinates management.....	119
5-2	Coordinate origin.....	122
5-3	Parameters related to ABZO sensor.....	123
5-4	Mechanism settings parameter.....	124
5-5	Initial coordinate generation & wrap coordinate parameters.....	125
5-6	Mechanism limit.....	129
5-7	Mechanism protection.....	130
6	Torque limiting function	131
7	Saving parameters	132

5 Object list

1	Composition of object dictionary	134
2	Objects of CoE communication area	135
2-1	Descriptions of each object.....	135
2-2	Object list.....	139

3	Objects of profile area	142
3-1	Descriptions of each object	142
3-2	Object list.....	151
4	Objects of manufacturer-specific area	154
4-1	Descriptions of each object	154
4-2	Object list.....	182

6 Troubleshooting

1	Alarms.....	196
1-1	Alarm reset	196
1-2	Alarm history	196
1-3	Generation condition of alarms.....	198
1-4	Alarm list	198
1-5	Timing chart.....	204
2	Information	205
2-1	Information history	207
2-2	Information list	207
3	Troubleshooting and remedial actions.....	212

7 Extended function

1	Gain tuning.....	214
1-1	Setting of load inertia.....	214
1-2	Setting of motor response.....	214
2	Vibration suppression	217
2-1	Command filter.....	217
2-2	Resonance suppression.....	218
2-3	Damping control.....	219
2-4	Electronic damper function	219
3	Cumulative load	220
4	Load factor monitor	222
5	Changing the function of the HOME PRESET switch	223
6	Simulating the driver operation.....	224
6-1	Preparation and operating procedure for driver simulation mode.....	225
6-2	Coordinates.....	226
6-3	Monitor	227
6-4	Operation.....	228
6-5	I/O signals	228
6-6	Alarms	228
7	Using general signals	229

1 Introduction



This part explains the product overview and safety precautions in addition to the types and descriptions about operating manuals.

◆ Table of contents

1	Introduction	6
1-1	Before using the product.....	6
1-2	Related operating manuals.....	6
1-3	How to use operating manuals	6
1-4	Screen display of MEXE02 software.....	7
2	Overview of the product.....	8
3	Safety precautions	9
3-1	Graphical symbols on the driver's front panel.....	10
3-2	Description of warning.....	11
4	Precautions for use.....	12

1 Introduction

1-1 Before using the product

Only qualified personnel of electrical and mechanical engineering should work with the product. Use the product properly after thoroughly reading the section "3 Safety precautions" on p.9. In addition, be sure to observe the contents described in warning, caution, and note in this manual. The product described in this document has been designed and manufactured to be incorporated in general industrial equipment. Do not use it for any other purpose. Oriental Motor Co., Ltd. is not responsible for any compensation for damage caused through failure to observe this warning.

1-2 Related operating manuals

For operating manuals, download from Oriental Motor Website Download Page or contact your nearest Oriental Motor sales office.

- **AZX** Series / Motorized Actuator equipped with **AZX** Series EtherCAT Compatible Driver OPERATING MANUAL Hardware Edition
- **AZX** Series / Motorized Actuator equipped with **AZX** Series EtherCAT Compatible Driver OPERATING MANUAL Software Edition (this document)

Read the following operating manuals for a motor or a motorized actuator.

- OPERATING MANUAL Motor Edition
- OPERATING MANUAL Actuator Edition
- Motorized Actuator OPERATING MANUAL Function Setting Edition

1-3 How to use operating manuals

To use the product, read both the Hardware Edition and the Software Edition (this document) of the **AZX** Series operating manuals.

The Hardware Edition describes installation, connection, and others.

The Software Edition describes operating methods, control methods via EtherCAT, object list, troubleshooting, and others.

1-4 Screen display of MEXE02 software

When the screen display of the **MEXE02** software is described, it may be indicated using a number such as "(p3)" described in front of the parameter type.

Example of description

Parameter

- Parameter
 - (p1) Objects of profile area
 - Objects of manufacturer-specific area
 - (p2) Base settings
 - (p3) Motor & Mechanism(Coordinates/JOG/Home operation)
 - (p4) ETO & Alarm & Info
 - (p5) I/O action and function
 - (p6) Direct-IN function(DIN)

MEXE02 code	Name	Description	Setting range	Initial value
p3	Mechanism protection parameter setting	Disables the ABZO setting of the mechanism protection parameter.	0: Follow ABZO setting 1: Disable	0

2 Overview of the product

■ How to set parameters

Parameters can be set via EtherCAT or using the **MEXE02** software.

■ Equipped with the power removal function





The power removal function is a function that stops supplying the power to the motor by the hardware. The power removal function is assumed to be used to prevent unexpected starting of the moving parts of equipment when an operator works inside the operating range of the moving parts.

■ Providing the ESI File

The ESI (EtherCAT SubDevice Information) file is a file that describes the specific information of the EtherCAT SubordinateDevice in XML format. By importing the ESI file to the EtherCAT Configuration Tool of a PLC (programmable controller), the settings of EtherCAT communication can be configured before the driver is delivered. The ESI file can be downloaded from Oriental Motor Website Download Page.



3 Safety precautions

The precautions described below are intended to ensure the safe and proper use of the product and to prevent the user and other personnel from exposure to the risk of injury. Use the product only after carefully reading and fully understanding these instructions.

 WARNING	Handling the product without observing the instructions that accompany a "WARNING" symbol may result in serious injury or death.
 CAUTION	Handling the product without observing the instructions that accompany a "CAUTION" symbol may result in injury or property damage.
	The items under this heading contain important handling instructions that the user should observe to ensure safe use of the product.
	The items under this heading contain related information and contents to gain a further understanding of the text in this manual.

WARNING

General

- Do not use the product in explosive or corrosive environments, in the presence of flammable gases, in areas subject to splashing water, or near combustible materials. Doing so may result in fire, electric shock, or injury.
- Assign qualified personnel to the task of installing, wiring, operating, inspecting, and troubleshooting the product. Handling by unqualified personnel may result in fire, electric shock, injury, or damage to equipment.
- Do not transport, install, connect, or inspect the product while the power is supplied. Doing so may result in electric shock.
- Do not touch the driver while the power is on. Doing so may result in fire or electric shock.
- Do not touch the terminals indicated   signs on the driver's front panel while the power is supplied because high voltage is applied. Doing so may result in fire or electric shock.
- When using the product in a vertical drive application such as elevating equipment, be sure to provide a means of holding the moving part in position. Failure to do so may result in injury or damage to equipment.
- When an alarm of the driver is generated (any of the driver's protective functions is triggered), remove the cause before resetting the alarm (protective function). Continuing the operation without correcting the cause of the problem may cause the motor and driver to malfunction, resulting in injury or damage to equipment.

Installation

- Install the driver in an enclosure. Failure to do so may result in electric shock or injury.
- Be sure to ground the driver as it is Class I equipment. Failure to do so may result in electric shock.

Connection

- Keep the input power voltage of the driver within the specified range. Failure to do so may result in fire or electric shock.
- Connect the product securely according to the wiring diagram. Failure to do so may result in fire or electric shock.
- Do not forcibly bend, pull, or pinch the cable. Doing so may result in fire or electric shock.

Operation

- Turn off the main power supply and the control power supply in the event of a power failure. Failure to do so may result in injury or damage to equipment.
- Take safety measures to protect against momentary voltage drops. Failure to do so may cause the motor to stop or reduce the holding force or rotational torque, resulting in injury or damage to equipment.
- Do not remove the motor excitation during operation. Doing so may cause the motor to stop and lose holding torque, resulting in injury or damage to equipment.

Repair, disassembly, and modification

- Do not disassemble or modify the driver. Doing so may result in injury or damage to equipment.

Maintenance and inspection

- Do not touch the connection terminals of the driver immediately after turning off the main power supply and the control power supply. Before performing connection or inspection, turn off the main power supply and the control power supply, and check the CHARGE LED has been turned off. Residual voltage may cause electric shock.

⚠ CAUTION

General

- Do not use the driver beyond the specifications. Doing so may result in electric shock, injury, or damage to equipment.
- Keep your fingers and objects out of the openings in the driver. Failure to do so may result in fire, electrical shock, or injury.
- Do not touch the driver during operation or immediately after stopping. Doing so may result in a skin burn(s).
- Do not forcibly bend or pull the cable that is connected to the driver. Doing so may cause damage to the product.

Installation

- Keep the area around the driver free of combustible materials. Failure to do so may result in fire or a skin burn(s).
- Do not leave anything around the driver that would obstruct ventilation. Doing so may result in damage to equipment.



Operation

- Use a motor and driver only in the specified combination. An incorrect combination may cause a fire.
- For the control power supply, use a DC power supply with reinforced insulation on its primary and secondary sides. Failure to do so may result in electric shock.
- Provide an emergency stop device or emergency stop circuit external to the equipment so that the entire system will operate safely in the event of a system failure or malfunction. Failure to do so may result in injury.
- Before turning on the main power supply and the control power supply, turn OFF all input signals to the driver. Failure to do so may result in injury or damage to equipment.
- When moving the moving part by hand, put the motor in a non-excitation state. Continuing to work while the motor is in an excitation state may result in injury.
- When an abnormal condition occurs, immediately stop operation to turn off the main power supply and the control power supply. Failure to do so may result in fire, electrical shock, or injury.
- Take measures against static electricity when operating the switches of the driver. Failure to do so may result in the driver malfunction or damage to equipment.

Inspection and maintenance

- Do not touch the terminals while conducting the insulation resistance measurement or dielectric strength test. Accidental contact may result in electric shock.

3-1 Graphical symbols on the driver's front panel







	⚠ WARNING This is the Protective Earth Terminal. Be sure to ground because improper grounding may result in electric shock.
	⚠ WARNING A high voltage is applied to the motor connector (CN3) and the main power supply input terminal (CN4). Do not touch them while the power is on. Doing so may result in fire or electric shock.

3-2 Description of warning

A warning about handling precautions is described on the driver.

Be sure to observe the description contents when handling the product.

Electrical hazard warning label

	WARNING – Risk of electric shock.
	<ul style="list-style-type: none"> • Read manual before installing. (Multiple rated) • Do not touch the driver immediately after the power is cut off, or until the CHARGE LED (lit in red) turns off. Doing so may result in electric shock due to residual voltage.
	AVERTISSEMENT – Risque de décharge électrique.
	<ul style="list-style-type: none"> • Lire le manuel avant l'installation. • Ne pas toucher au variateur immédiatement après la mise hors tension ou avant que la LED "présence de la tension" (Rouge) ne soit éteinte. Le non respect de ces règles pourrait entraîner un choc électrique.
	警告 – けが・感電のおそれがあります。
	<ul style="list-style-type: none"> • 据え付け、運転の前には必ず取扱説明書をお読み下さい。 • 電源を切った直後、CHARGE LED(赤色点灯)が消灯するまでドライバに触れないで下さい。残留電圧により感電の原因になります。

Material: PET

4 Precautions for use

This chapter explains restrictions and requirements the user should consider when using the product.

- **Always use Oriental Motor cables to connect a motor and a driver.**

Check on the Oriental Motor Website for the cable models.

- **When conducting the insulation resistance measurement or the dielectric strength test, be sure to separate the connection between the motor and the driver.**

Conducting the insulation resistance measurement or the dielectric strength test with the motor and driver connected may result in damage to the product.

- **Preventing leakage current**

Stray capacitance exists between the driver's current-carrying line and other current-carrying lines, the earth and the motor, respectively. A high-frequency current may leak out through such capacitance, having a detrimental effect on the surrounding equipment. The actual leakage current depends on the driver's switching frequency, the length of wiring between the driver and motor, and so on. When installing an earth leakage breaker, use a product offering resistance against high frequency current such as the one specified below.

Mitsubishi Electric Corporation: NV series

- **If a vertical drive such as gravitational operation is performed or if sudden start-stop operation of a large inertia is repeated frequently, connect the Oriental Motor regeneration resistor RGB200.**

The factory setting is to use the built-in regeneration resistor. Using the built-in regeneration resistor, however, continuous regeneration operation, vertical drive such as gravitational operation, or sudden start-stop operation of a large inertia cannot be performed. When performing such operation, use the Oriental Motor regeneration resistor **RGB200**. Refer to the [OPERATING MANUAL Hardware Edition](#) for the connection method.

- **Note when connecting a main power supply and a control power supply whose positive sides are grounded**

The USB connector, CN5, CN6, and CN7 connectors on the driver are not electrically insulated. When grounding the positive terminal of the power supply, do not connect any equipment (PC, etc.) whose negative terminal is grounded. Doing so may cause the driver and this equipment to short, damaging both. When connecting, do not ground equipment.

- **Saving data to the non-volatile memory**

Do not turn off the control power supply while writing the data to the non-volatile memory, and also do not turn off for five seconds after the completion of writing the data. Doing so may abort writing the data and cause an alarm of EEPROM error to generate. The non-volatile memory can be rewritten approximately 100,000 times.

- **Noise elimination measures**

Refer to the [OPERATING MANUAL Hardware Edition](#) for noise elimination measures.

2 Before starting operation

This part explains the contents to be performed before starting the operation.

◆ Table of contents

1	Operation preparation flow	14
2	Copy the ABZO information (fixed value) to the driver.....	15
3	Setting of resolution	16
4	Home setting.....	18
5	Backup of data	19

1 Operation preparation flow

Use the **MEXE02** software to prepare for operation.
 The procedures for a motor and a motorized actuator are different. Prepare for operation according to the product being used.

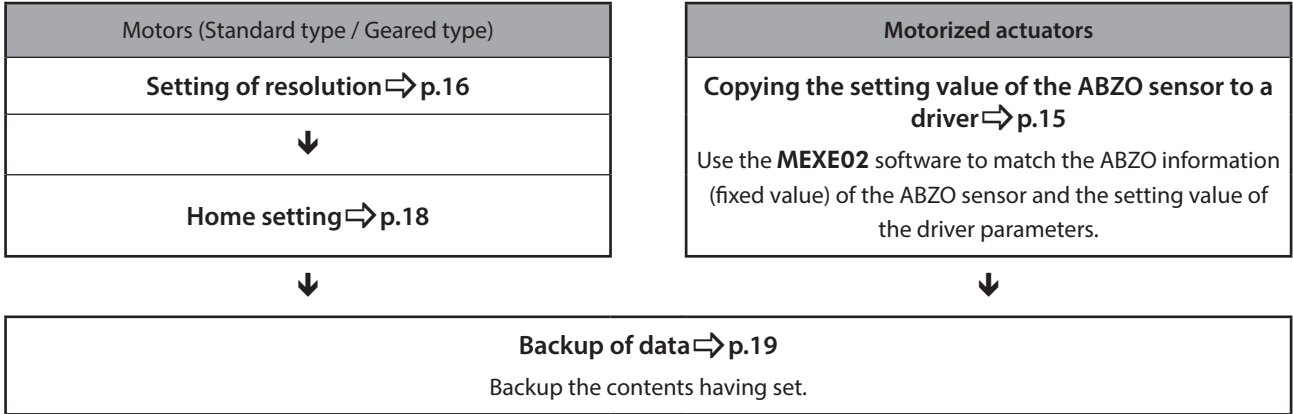

2 Copy the ABZO information (fixed value) to the driver

For the parameters of a motorized actuator, the different values have been stored in the ABZO sensor and the driver, respectively.

The values based on the product specifications, such as the recommended coordinate information, are stored in the ABZO sensor of a motorized actuator. The values stored in the ABZO sensor cannot be changed because of the fixed value.

Meantime, the values for the standard type (motor only) are stored in the driver parameters.

In the factory default state, the parameter information (fixed value) stored in the ABZO sensor is used preferentially. However, if a parameter is changed with the **MEXE02** software or others, all parameters including the changed parameter will be changed to the values set in the driver. Therefore, an unexpected movement may cause when operation is executed. In order to prevent such problems, copy the ABZO information (fixed value) to the driver, and match the data in the driver parameter with the fixed value in the ABZO sensor.

Note Before copying the ABZO information (fixed value) of the product to the driver, once the parameter (such as electronic gear) is changed to "Manual setting" using the **MEXE02** software and written to the driver, the parameter having changed will not return to the fixed value even if the ABZO information (fixed value) is copied.

■ Procedure

Using the **MEXE02** software, copy the ABZO information (fixed value) of the ABZO sensor to the driver.

1. Turn on the control power supply of the driver.
2. Click [Copy the ABZO (fixed) information to the driver in a lump] under the [Communication] menu.
The ABZO information (fixed value) is copied to the driver.
3. Turn on the control power supply of the driver again.
4. Check that the copied data is updated in the unit information monitor window.
The contents of each item are shown in the table.

Item	Description
Active	Indicates the parameter values presently used.
Driver parameter	Indicates the parameter values set in the driver with the MEXE02 software or via EtherCAT.
ABZO (fixed)	Indicates the parameter values stored in the ABZO sensor. They cannot be changed because of the fixed value.

3 Setting of resolution

Set the resolution when used in combination with a mechanism such as a geared motor or motorized actuator. If the "Electronic gear A" and "Electronic gear B" parameters are set, the resolution per revolution of the output shaft can be set.

Note that the calculated value must fall within the setting range specified below.

Setting range of resolution: 100 to 10,000 P/R (Initial value: 10,000 P/R)

$$\text{Resolution (P/R)} = 10,000 \times \frac{\text{Electronic gear B}}{\text{Electronic gear A}}$$

Related parameters

MEXE02 code	Name	Description	Setting range	Initial value
p3	Mechanism settings	To change the mechanism settings parameter, select "1: Manual setting."	0: Prioritize ABZO setting 1: Manual setting	0
p1	Electronic gear A	Sets the denominator of the electronic gear.	1 to 65,535	1
	Electronic gear B	Sets the numerator of the electronic gear.		

- Note**
- When the "Mechanism settings" parameter is changed, turn off the control power supply of the driver and on again.
 - If a resolution out of the setting range is set, information of Electronic gear setting error will be generated. If the control power supply is turned on again or Configuration is executed in a state where information of Electronic gear setting error is generated, an alarm of Electronic gear setting error will be generated.
 - If the resolution was changed after preset was executed in a state where the "Preset position" parameter is set to other than "0," execute preset once again. If the "Preset position" parameter is set to "0," the present position is automatically recalculated even if the resolution is changed.

memo The initial value of the resolution may vary depending on the product connected.

■ Calculation method of electronic gears A and B

This section explains how to calculate the electronic gears A and B with examples of a ball screw and rotary table.

● Calculation example 1: Ball screw

- When a ball screw with a lead of 6 mm should be moved 0.001 mm per step.
- Gear ratio: 1 (No speed reduction mechanism between the motor and ball screw.)

$$\text{Resolution on mechanism} = 10,000 \times \frac{\text{Electronic gear B}}{\text{Electronic gear A}} = \frac{\text{Ball screw lead}}{\text{Minimum travel amount}}$$

$$\text{In this example: } 10,000 \times \frac{\text{Electronic gear B}}{\text{Electronic gear A}} = \frac{6 \text{ mm}}{0.001 \text{ mm}}$$

$$\text{By calculation: } \frac{\text{Electronic gear B}}{\text{Electronic gear A}} = \frac{6}{10}$$

Therefore, the electronic gear A is 10 and the electronic gear B is 6, and the resolution is 6,000 P/R.

● **Calculation example 2: Rotary table**

- When a rotary table that moves by 360° per revolution should be moved by 0.01° per step.
- Gear ratio: 10 (A geared motor with a gear ratio of 10 is used)

$$\text{Resolution on mechanism} = 10,000 \times \frac{\text{Electronic gear B}}{\text{Electronic gear A}} = \frac{\text{Travel amount per revolution}}{\text{Minimum travel amount}} \times \frac{1}{\text{Gear ratio}}$$

$$\text{In this example: } 10,000 \times \frac{\text{Electronic gear B}}{\text{Electronic gear A}} = \frac{360^\circ}{0.01^\circ} \times \frac{1}{10}$$

$$\text{By calculation: } \frac{\text{Electronic gear B}}{\text{Electronic gear A}} = \frac{36}{100}$$

Therefore, the electronic gear A is 100 and the electronic gear B is 36, and the resolution is 3,600 P/R.

4 Home setting

The home is not set at the time of shipment. Before starting operation, be sure to set the home. Perform the home setting only once initially. Once the home is fixed, the home information is retained even if the power supply is shut off.



The home is written to the non-volatile memory. The non-volatile memory can be rewritten approximately 100,000 times.

■ Home setting method

There are two ways to set the home, the HOME PRESET switch and return-to-home operation. This section describes how to set the home using the HOME PRESET switch. Refer to "3-7 Homing mode (HM)" on p.91 for return-to-home operation.

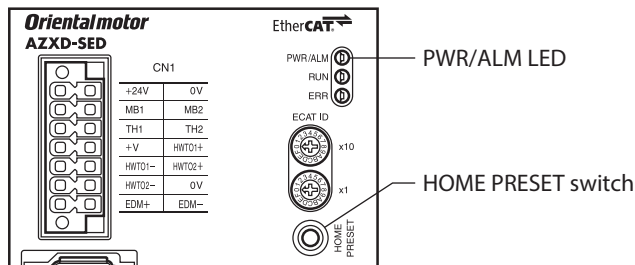

1. Move the output shaft to the position that is desired to set as the home.
2. Check the control power supply has been turned on, and press and hold the HOME PRESET switch for one second. The PWR/ALM LED blinks in red and green at the same time. (Red and green colors may overlap and it may be visible to orange.)
3. Release a hand off within three seconds after the PWR/ALM LED started blinking, and press the HOME PRESET switch again within three seconds after releasing the hand off. The PWR/ALM LED is lit in red and green at the same time, and then it is lit in green only.
4. The home is set.



For the operation of the step 3, be sure to release a hand off after the PWR/ALM LED started blinking and perform within three seconds. If three seconds elapsed in either of the two processes, the PWR/ALM LED is returned to the state of being lit in green. In this case, perform from the step 2 again.

5 Backup of data

There are two methods to backup the contents set in the **MEXE02** software as shown below.

■ Create to save the data file

The data edited in the **MEXE02** software or the data read from the driver is saved as a file. Click [Save As] under the [File] menu.

■ Save in the backup area of the driver

Save the data opened in the **MEXE02** software to the backup area of the driver.

● When saving with the **MEXE02** software

1. Click [Backup] under the [Communication] menu.
2. Input the Access key and the Write key.
3. Click [Backup].



Data saved by backup can be read by clicking [Restore] under the [Communication] menu.

● When saving via EtherCAT

Set the key code using the Backup DATA access key (4020h) and the Backup DATA write key (4021h), and then execute the Write to backup (40CCh) of the maintenance command.

Related objects

Index	Sub	Name	Type	Access	PDO	Save	Initial value	Range	Update
4020h	00h	Backup DATA access key	INT32	RW	No	–	0	Key code: 20519253 (01391955h)	A
4021h	00h	Backup DATA write key	INT32	RW	No	–	0	Key code: 1977326743 (75DB9C97h)	A
40CBh	00h	Read from backup	U8	RW	No	–	0	–	–
40CCh	00h	Write to backup	U8	RW	No	–	0	–	–



When reading the data saved by the backup function, set the key code using the Backup DATA access key (4020h). And then execute the Read from backup (40CBh) of the maintenance command.

3 I/O signals

This part explains input signals and output signals.

◆ Table of contents

1	Overview of I/O signals	22
1-1	Overview of input signals.....	22
1-2	Overview of output signals.....	24
1-3	Setting contents of input signals and output signals	25
2	Signals list	30
2-1	Input signals list	30
2-2	Output signals list.....	31
3	Signal type	34
3-1	Direct I/O.....	34
3-2	Remote I/O	38
4	Input signals	40
4-1	Operation control.....	40
4-2	Position coordinate management.....	47
4-3	Management of driver	48
5	Output signals.....	49
5-1	Management of driver	49
5-2	Management of operation.....	50
5-3	Response outputs.....	57
6	Timing chart	58

1 Overview of I/O signals

1-1 Overview of input signals

■ Direct input

Direct input (DIN) is a method in which a signal is input directly by connecting the I/O cable to the connector. If the composite input function is used, a single input can turn two signals ON simultaneously, achieving saving of wiring.

Name	Description
Input function	Selects an input signal to be assigned to DIN.
Inverting mode	The ON-OFF setting of the signal can be changed.
ON signal dead-time	The input signal is turned ON when the time having set is exceeded. This can be used to take a measure to eliminate the noise or to adjust the timing between the devices.
1 shot signal	The input signal having been turned ON is automatically turned OFF after 250 μs.
Composite input function	When DIN is turned ON, the signal selected here is also turned ON.

Setting example: When the STOP input is turned ON during operation, turn the FREE input ON to put the motor in a non-excitation state.

If the parameters are set as shown in the table, the motor will be in a non-excitation state when the STOP input is turned ON.

MEXE02 code	Name	Setting value
p6	Input function	STOP
	Inverting mode	Non invert
	ON signal dead-time	0 ms
	1 shot signal	1 shot signal function is disabled
	Composite input function	FREE

■ Virtual input

Virtual input (VIR-IN) is a method in which a signal set in virtual input is input by using output of a signal set in the virtual input source.

No wiring is required and this function can be used together with direct I/O because of the input method using the internal I/O. Up to four virtual inputs can be set.

Name	Description
Virtual input function	Selects an input signal to be assigned to VIR-IN. When a signal of the virtual input source is output, VIR-IN is also turned ON.
Virtual input source selection	Selects an output signal to be the trigger of VIR-IN.
Virtual input inverting mode	The ON-OFF setting of the signal can be changed.
Virtual input ON signal dead time	The input signal is turned ON when the time having set is exceeded. This can be used to take a measure to eliminate the noise or to adjust the timing between the devices.
Virtual input 1 shot signal mode	The input signal having been turned ON is automatically turned OFF after 250 μ s.

Setting example: When the TLC output is turned ON, turn the STOP input ON to stop the motor.

If the parameters are set as shown in the table, the motor stops when the output torque reaches the upper limit.

MEXE02 code	Name	Setting value
p9	Virtual input (VIR-IN0) function	STOP
	Virtual input (VIR-IN0) source selection	TLC
	Virtual input (VIR-IN0) inverting mode	Non invert
	Virtual input (VIR-IN0) ON signal dead time	0 ms
	Virtual input (VIR-IN0) 1 shot signal mode	1 shot signal function is disabled

1-2 Overview of output signals

■ Direct output

Direct output (DOUT) is a method in which a signal is output directly by connecting the I/O cable to the connector. If the composite output function is used, the logical combination result of two output signals can be output in a single signal.

Name	Description
(Normal) Output function	Selects an output signal to be assigned to DOUT.
Inverting mode	The ON-OFF setting of the signal can be changed.
OFF delay time	The output signal is turned OFF when the time having set is exceeded. This can be used to take a measure to eliminate the noise or to adjust the timing between the devices.
Composite logical combination	Sets the logical combination [AND (logical product) or OR (logical sum)] of the composite output function.
Composite output function	Selects an output signal for logical operation with the signal of DOUT. When logical combination of the two signals is established, DOUT is turned ON.
Composite inverting mode	Changes the ON-OFF setting of the signal selected in the composite output function.

Setting example: When the HOME-END output and the AREA0 output are turned ON, HOME-END (DOUT0) is output.

If parameters are set as shown in the table, the status of completing return-to-home and reaching to the specified position can be checked by a single output signal (DOUT0).

MEXE02 code	Name	Setting value
p7	(Normal) Output function	HOME-END
	Inverting mode	Non invert
	OFF delay time	0 ms
	Composite logical combination	AND
	Composite output function	AREA0
	Composite inverting mode	Non invert

■ User output

User output (USR-OUT) is a method in which a signal is output by using the internal I/O.

Assign two types of signals (A and B) to a single user output. USR-OUT is output when the logical combination of A and B is established.

No wiring is required and this function can be used together with direct I/O. Up to two user outputs can be set.

Name	Description
User output source A function	Selects the output function A.
User output source A inverting mode	Changes the ON-OFF setting of the output function A.
User output source B function	Selects the output function B.
User output source B inverting mode	Changes the ON-OFF setting of the output function B.
User output logical operation	Sets the logical combination [AND (logical product) or OR (logical sum)] of the output function sources A and B.

Setting example: When the IN-POS output and the READY output are turned ON, USR-OUT is output.

If the parameters are set as shown in the table, the status where positioning operation is completed and operation is ready to start can be checked by a single output signal (USR-OUT0).

MEXE02 code	Name	Setting value
p9	User output (USR-OUT0) source A function	IN-POS
	User output (USR-OUT0) source A inverting mode	Non invert
	User output (USR-OUT0) source B function	READY
	User output (USR-OUT0) source B inverting mode	Non invert
	User output (USR-OUT0) logical operation	AND

1-3 Setting contents of input signals and output signals

■ Direct input

● Input function

MEXE02 code	Name	Description	Setting range	Initial value
p6	DIN0 input function	Selects an input signal to be assigned to DIN.	Input signals list ⇨ p.30	30: HOMES
	DIN1 input function			1: FREE
	DIN2 input function			12: ETO-CLR
	DIN3 input function			104: EXT1
	DIN4 input function			28: FW-LS
	DIN5 input function			29: RV-LS

● Change of ON-OFF setting of input signals

MEXE02 code	Name	Description	Setting range	Initial value
p6	DIN0 inverting mode	Changes the ON-OFF setting of DIN.	0: Non invert 1: Invert	0
	DIN1 inverting mode			0
	DIN2 inverting mode			0
	DIN3 inverting mode			0
	DIN4 inverting mode			0
	DIN5 inverting mode			0

● **ON signal dead-time**

MEXE02 code	Name	Description	Setting range	Initial value
p6	DIN0 ON signal dead-time	Sets the ON signal dead-time of DIN.	0 to 250 ms	0
	DIN1 ON signal dead-time			0
	DIN2 ON signal dead-time			0
	DIN3 ON signal dead-time			0
	DIN4 ON signal dead-time			0
	DIN5 ON signal dead-time			0

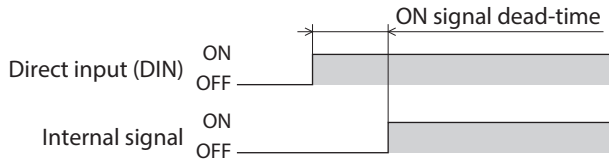

● **1 shot signal**

MEXE02 code	Name	Description	Setting range	Initial value
p6	DIN0 1 shot signal	Sets the 1-shot signal function of DIN.	0: 1 shot signal function is disabled 1: 1 shot signal function is enabled	0
	DIN1 1 shot signal			0
	DIN2 1 shot signal			0
	DIN3 1 shot signal			0
	DIN4 1 shot signal			0
	DIN5 1 shot signal			0

Note The HMI input is a signal that is recommended to be used as normally closed (always ON). When the HMI input is assigned to DIN, use in a state of keeping the "1 shot signal" parameter as "0: 1 shot signal function is disabled."

● **Composite input function**

MEXE02 code	Name	Description	Setting range	Initial value
p6	DIN0 composite input function	Selects an input signal to be assigned to DIN as the composite input function.	Input signals list ⇒ p.30	0: No function
	DIN1 composite input function			0: No function
	DIN2 composite input function			0: No function
	DIN3 composite input function			0: No function
	DIN4 composite input function			0: No function
	DIN5 composite input function			0: No function

■ **Virtual input**

● **Virtual input function**

MEXE02 code	Name	Description	Setting range	Initial value
p9	Virtual input (VIR-IN0) function	Selects an input signal to be assigned to VIR-IN.	Input signals list ⇒ p.30	0: No function
	Virtual input (VIR-IN1) function			0: No function
	Virtual input (VIR-IN2) function			0: No function
	Virtual input (VIR-IN3) function			0: No function

- Virtual input source selection

MEXE02 code	Name	Description	Setting range	Initial value
p9	Virtual input (VIR-IN0) source selection	Selects an output signal to be the trigger of VIR-IN.	Output signals list ⇒ p.31	128: CONST-OFF
	Virtual input (VIR-IN1) source selection			128: CONST-OFF
	Virtual input (VIR-IN2) source selection			128: CONST-OFF
	Virtual input (VIR-IN3) source selection			128: CONST-OFF

- Virtual input inverting mode

MEXE02 code	Name	Description	Setting range	Initial value
p9	Virtual input (VIR-IN0) inverting mode	Changes the ON-OFF setting of VIR-IN.	0: Non invert 1: Invert	0
	Virtual input (VIR-IN1) inverting mode			0
	Virtual input (VIR-IN2) inverting mode			0
	Virtual input (VIR-IN3) inverting mode			0

- Virtual input ON signal dead time

MEXE02 code	Name	Description	Setting range	Initial value
p9	Virtual input (VIR-IN0) ON signal dead time	Sets the ON signal dead-time of VIR-IN.	0 to 250 ms	0
	Virtual input (VIR-IN1) ON signal dead time			0
	Virtual input (VIR-IN2) ON signal dead time			0
	Virtual input (VIR-IN3) ON signal dead time			0

- Virtual input 1 shot signal mode

MEXE02 code	Name	Description	Setting range	Initial value
p9	Virtual input (VIR-IN0) 1 shot signal mode	Enables the 1-shot signal function of VIR-IN.	0: 1 shot signal function is disabled 1: 1 shot signal function is enabled	0
	Virtual input (VIR-IN1) 1 shot signal mode			0
	Virtual input (VIR-IN2) 1 shot signal mode			0
	Virtual input (VIR-IN3) 1 shot signal mode			0

■ Direct output

- (Normal) Output function

MEXE02 code	Name	Description	Setting range	Initial value
p7	DOUT0 (Normal) output function	Selects an output signal to be assigned to DOUT.	Output signals list ⇒ p.31	144: HOME-END
	DOUT1 (Normal) output function			137: ETO-MON
	DOUT2 (Normal) output function			0: No function
	DOUT3 (Normal) output function			142: SON-MON
	DOUT4 (Normal) output function			134: MOVE
	DOUT5 (Normal) output function			130: ALM-B

● Inverting mode

MEXE02 code	Name	Description	Setting range	Initial value
p7	DOUT0 inverting mode	Changes the ON-OFF setting of DOUT.	0: Non invert 1: Invert	0
	DOUT1 inverting mode			0
	DOUT2 inverting mode			0
	DOUT3 inverting mode			0
	DOUT4 inverting mode			0
	DOUT5 inverting mode			0

● OFF delay time

MEXE02 code	Name	Description	Setting range	Initial value
p7	DOUT0 OFF delay time	Sets the OFF delay time of DOUT.	0 to 250 ms	0
	DOUT1 OFF delay time			0
	DOUT2 OFF delay time			0
	DOUT3 OFF delay time			0
	DOUT4 OFF delay time			0
	DOUT5 OFF delay time			0

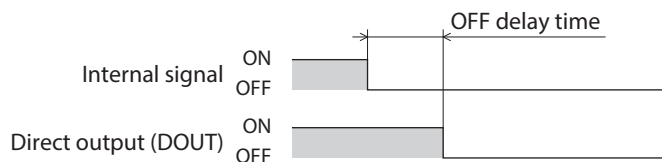

● Composite logical combination

MEXE02 code	Name	Description	Setting range	Initial value
p7	DOUT0 composite logical combination	Sets the composite logical combination of DOUT.	0: AND 1: OR	1
	DOUT1 composite logical combination			1
	DOUT2 composite logical combination			1
	DOUT3 composite logical combination			1
	DOUT4 composite logical combination			1
	DOUT5 composite logical combination			1

● Composite output function

MEXE02 code	Name	Description	Setting range	Initial value
p7	DOUT0 composite output function	Selects an output signal for logical operation with the signal of DOUT.	Output signals list ⇒ p.31	128: CONST-OFF
	DOUT1 composite output function			128: CONST-OFF
	DOUT2 composite output function			128: CONST-OFF
	DOUT3 composite output function			128: CONST-OFF
	DOUT4 composite output function			128: CONST-OFF
	DOUT5 composite output function			128: CONST-OFF

- **Composite inverting mode**

MEXE02 code	Name	Description	Setting range	Initial value
p7	DOUT0 composite inverting mode	Changes the ON-OFF setting of the composite output function of DOUT.	0: Non invert 1: Invert	0
	DOUT1 composite inverting mode			0
	DOUT2 composite inverting mode			0
	DOUT3 composite inverting mode			0
	DOUT4 composite inverting mode			0
	DOUT5 composite inverting mode			0

- **User output**

- **User output source A function**

MEXE02 code	Name	Description	Setting range	Initial value
p9	User output (USR-OUT0) source A function	Sets the output source A of USR-OUT.	Output signals list ⇒ p.31	128: CONST-OFF
	User output (USR-OUT1) source A function			128: CONST-OFF

- **User output source A inverting mode**

MEXE02 code	Name	Description	Setting range	Initial value
p9	User output (USR-OUT0) source A inverting mode	Changes the ON/OFF setting of the output source A of USR-OUT.	0: Non invert 1: Invert	0
	User output (USR-OUT1) source A inverting mode			0

- **User output source B function**

MEXE02 code	Name	Description	Setting range	Initial value
p9	User output (USR-OUT0) source B function	Sets the output source B of USR-OUT.	Output signals list ⇒ p.31	128: CONST-OFF
	User output (USR-OUT1) source B function			128: CONST-OFF

- **User output source B inverting mode**

MEXE02 code	Name	Description	Setting range	Initial value
p9	User output (USR-OUT0) source B inverting mode	Changes the ON/OFF setting of the output source B of USR-OUT.	0: Non invert 1: Invert	0
	User output (USR-OUT1) source B inverting mode			0

- **User output logical operation**

MEXE02 code	Name	Description	Setting range	Initial value
p9	User output (USR-OUT0) logical operation	Sets the logical combination of the output sources A and B of USR-OUT.	0: AND 1: OR	1
	User output (USR-OUT1) logical operation			1

2 Signals list

Assign I/O signals using the **MEXE02** software or via EtherCAT.

To assign signals via EtherCAT, use the "Assignment number" in the table instead of the signal name.

2-1 Input signals list

Refer to "4 Input signals" on p.40 for details about each signal.

Assignment number	Signal name	Function
0	No function	Set when the input terminal is not used.
1	FREE	Shut off the motor current to put the motor in a non-excitation state. In the case of an electromagnetic brake motor, the electromagnetic brake is released.
3	CLR	Clear the deviation (position deviation) between the command position and the feedback position.
5	STOP	Stop the motor.
8	ALM-RST	Reset the alarm generated presently.
9	P-PRESET	Rewrite the mechanical home to the present position.
12	ETO-CLR	If the ETO-CLR input is turned ON after both the HWTO1 and HWTO2 inputs are turned ON to release the power removal function, the motor will be in a state where it can be excited.
13	LAT-CLR	Clear the cumulative load. This is used when the Cumulative load value auto clear (41B3h) is set to "0: Disable."
14	INFO-CLR	Clear the information status.
16	HMI	Release the function limitation of the MEXE02 software.
22	TRQ-LMT	Execute the torque limiting.
23	SPD-LMT	Execute speed limiting. This signal cannot be used in the Cyclic synchronous position mode (CSP).
26	FW-BLK	Stop the operation in the forward direction.
27	RV-BLK	Stop the operation in the reverse direction.
28	FW-LS	This is a signal to be input from the limit sensor in the forward direction.
29	RV-LS	This is a signal to be input from the limit sensor in the reverse direction.
30	HOMES	This is a signal input from the mechanical home sensor.
31	SLIT	This is a signal to be input from the slit sensor.
80	R0	These are general signals.
81	R1	
82	R2	
83	R3	
84	R4	
85	R5	
86	R6	
87	R7	
88	R8	
89	R9	
90	R10	
91	R11	
92	R12	
93	R13	
94	R14	
95	R15	

Assignment number	Signal name	Function
104	EXT1	This is an external latch signal for the touch probe 1.
105	EXT2	This is an external latch signal for the touch probe 2.

2-2 Output signals list

Refer to "5 Output signals" on p.49 for details about each signal.

Assignment number	Signal name	Function
0	No function	Set when the output terminal is not used.
1	FREE_R	Output in response to an input signal.
3	CLR_R	
5	STOP_R	
8	ALM-RST_R	
9	P-PRESET_R	
12	ETO-CLR_R	
13	LAT-CLR_R	
14	INFO-CLR_R	
16	HMI_R	
22	TRQ-LMT_R	
23	SPD-LMT_R	
26	FW-BLK_R	
27	RV-BLK_R	
28	FW-LS_R	
29	RV-LS_R	
30	HOMES_R	
31	SLIT_R	
80	R0_R	
81	R1_R	
82	R2_R	
83	R3_R	
84	R4_R	
85	R5_R	
86	R6_R	
87	R7_R	
88	R8_R	
89	R9_R	
90	R10_R	
91	R11_R	
92	R12_R	
93	R13_R	
94	R14_R	
95	R15_R	
128	CONST-OFF	Output an OFF state all the time.
129	ALM-A	Output the alarm status of the driver (normally open).
130	ALM-B	Output the alarm status of the driver (normally closed).
131	SYS-RDY	Output when the control power supply of the driver is turned on.
132	READY	Output when the driver is ready to operate.

Assignment number	Signal name	Function
134	MOVE	Output while the motor operates.
135	INFO	Output the information status of the driver.
136	SYS-BSY	Output when the driver is in an internal processing state.
137	ETO-MON	Output after the HWTO1 input or the HWTO2 input is turned OFF until the motor is in a state where it can be excited.
138	IN-POS	Output when positioning operation is completed. This signal is not output in the Cyclic synchronous position mode (CSP).
139	ZV	Output when the feedback speed reaches the speed 0.
140	TLC	Output when the output torque reaches the maximum output torque or the torque limiting value.
141	VA	Output when the operating speed reaches the target speed. This signal is not output in the Cyclic synchronous position mode (CSP).
142	SON-MON	Output when the motor is in an excitation state.
144	HOME-END	Output when return-to-home (homing) operation is completed or position preset is executed.
145	ABSPEN	Output when coordinates are set.
149	PRST-DIS	After preset, this signal is turned ON when preset is required again before the motor is operated.
150	PRST-STLD	Output when the mechanical home is set.
151	ORGN-STLD	Output when the mechanical home is set in accordance with the product at the time of factory shipment.
152	RND-OVF	The output is inverted when the wrap range is exceeded. (Toggle action)
153	FW-SLS	Output when the software limit in the forward direction is reached.
154	RV-SLS	Output when the software limit in the reverse direction is reached.
155	ZSG	Output each time the feedback position of the motor rotates one revolution from the preset position.
156	RND-ZERO	Output when the motor is at the home of the wrap range in a state where the Wrap (RND) setting (41C7h) is set to "1: enable."
160	AREA0	Output when the motor is within the area.
161	AREA1	
162	AREA2	
163	AREA3	
164	AREA4	
165	AREA5	
166	AREA6	
167	AREA7	
168	MPS	Output when the main power supply is in an ON state.
169	MBC	Output when the electromagnetic brake is in a state of releasing the motor shaft.
170	RG	Output when the driver is in a regeneration state.
172	EDM-MON	Output when both the HWTO1 and HWTO2 inputs are turned OFF.
173	HWTOIN-MON	Output when either the HWTO1 input or the HWTO2 input is turned OFF.
180	USR-OUT0	Output a logical product (AND) or a logical sum (OR) for two types of output signals.
181	USR-OUT1	
192	TRQ-LMTD	Output while torque limiting is performed.
193	SPD-LMTD	Output while speed limiting is performed.
196	OPE-BSY	Output while internal oscillation is performed.
204	DCMD-RDY	Output when the driver is ready to operate.
205	DCMD-FULL	Output while data is written in the buffer area. If operation of Set of Set-points is performed in the Profile position mode (PP), the operation command is written in the buffer area.

Assignment number	Signal name	Function
206	OL-DTCT	Output when the output torque reaches the torque to detect the overload alarm.
224	INFO-USRIO	Output when the corresponding information is generated. Refer to p.207 for the information list.
225	INFO-POSERR	
226	INFO-DRVTMP	
227	INFO-MTRTMP	
228	INFO-OVOLT	
229	INFO-UVOLT	
230	INFO-TLCTIME	
231	INFO-LOAD	
232	INFO-SPD	
233	INFO-START	
234	INFO-ZHOME	
235	INFO-PR-REQ	
237	INFO-EGR-E	
238	INFO-RND-E	
240	INFO-FW-OT	
241	INFO-RV-OT	
242	INFO-CULD0	
243	INFO-CULD1	
244	INFO-TRIP	
245	INFO-ODO	
247	INFO-TRQ	
248	INFO-STLTIME	
252	INFO-DSLMTD	
253	INFO-IOTEST	
254	INFO-CFG	
255	INFO-RBT	

3 Signal type

3-1 Direct I/O

Direct I/O is I/O to be accessed via the I/O signal connector.

■ Assignment to input terminals

Use parameters to assign the input signals to the input terminals DIN0 to DIN5.
Refer to "2-1 Input signals list" on p.30 for input signals that can be assigned.

Connector terminal number	Terminal name	Initial value
3	DIN0	HOMES
4	DIN2	ETO-CLR
6	DIN4	FW-LS

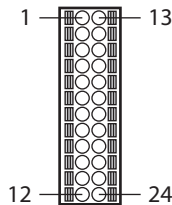

Connector terminal number	Terminal name	Initial value
15	DIN1	FREE
16	DIN3	EXT1
18	DIN5	RV-LS

● Related parameters

MEXE02 code	Name	Description	Setting range	Initial value
p6	DIN0 input function	Selects an input signal to be assigned to DIN.	Input signals list ⇒ p.30	30: HOMES
	DIN1 input function			1: FREE
	DIN2 input function			12: ETO-CLR
	DIN3 input function			104: EXT1
	DIN4 input function			28: FW-LS
	DIN5 input function			29: RV-LS



- When the same input signal is assigned to multiple input terminals, the function will be executed if any of the terminals becomes active.
- When the HMI input is not assigned to an input terminal, this input will always be in an ON state. If it is assigned to both direct I/O and remote I/O, the function will be executed only when both of them are turned ON.

■ Assignment to output terminals

Use parameters to assign the output signals to the output terminals DOUT0 to DOUT5.
Refer to "2-2 Output signals list" on p.31 for output signals that can be assigned.

Connector terminal number	Terminal name	Initial value
7	DOUT0	HOME-END
8	DOUT2	No function
9	DOUT4	MOVE

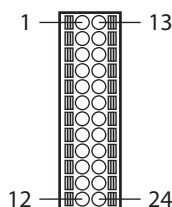

Connector terminal number	Terminal name	Initial value
19	DOUT1	ETO-MON
20	DOUT3	SON-MON
21	DOUT5	ALM-B

● Related parameters

MEXE02 code	Name	Description	Setting range	Initial value
p7	DOUT0 (Normal) output function	Selects an output signal to be assigned to DOUT.	Output signals list ⇒ p.31	144: HOME-END
	DOUT1 (Normal) output function			137: ETO-MON
	DOUT2 (Normal) output function			0: No function
	DOUT3 (Normal) output function			142: SON-MON
	DOUT4 (Normal) output function			134: MOVE
	DOUT5 (Normal) output function			130: ALM-B

■ Pin assignments list



- All input signals of the driver are photocoupler inputs.
- The status of signals is shown as follows.
I/O signals for normally open: "ON: Current-carrying" "OFF: Not current-carrying"
I/O signals for normally closed: "ON: Not current-carrying" "OFF: Current-carrying"

Pin No.	Signal name	Description*
1	NC	No connection
2	NC	No connection
3	IN0	Control input 0 (HOMES)
4	IN2	Control input 2 (ETO-CLR)
5	IN-COM 0-3	IN0 to IN3 inputs common
6	IN4	Control input 4 (FW-LS)
7	OUT0	Control output 0 (HOME-END)
8	OUT2	Control output 2 (Not used)
9	OUT4	Control output 4 (MOVE)
10	OUT-COM	Output common
11	ASG+	Phase A pulse output positive
12	BSG+	Phase B pulse output positive

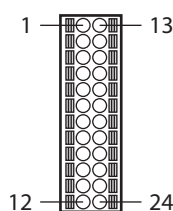

Pin No.	Signal name	Description*
13	NC	No connection
14	NC	No connection
15	IN1	Control input 1 (FREE)
16	IN3	Control input 3 (EXT1)
17	IN-COM 4-5	IN4, IN5 Inputs common
18	IN5	Control input 5 (RV-LS)
19	OUT1	Control output 1 (ETO-MON)
20	OUT3	Control output 3 (SON-MON)
21	OUT5	Control output 5 (ALM-B)
22	GND	GND
23	ASG-	Phase A pulse output -
24	BSG-	Phase B pulse output -

* (): Initial value

■ Connection example with a current sink output circuit

Values in parentheses () in the figure are initial values.

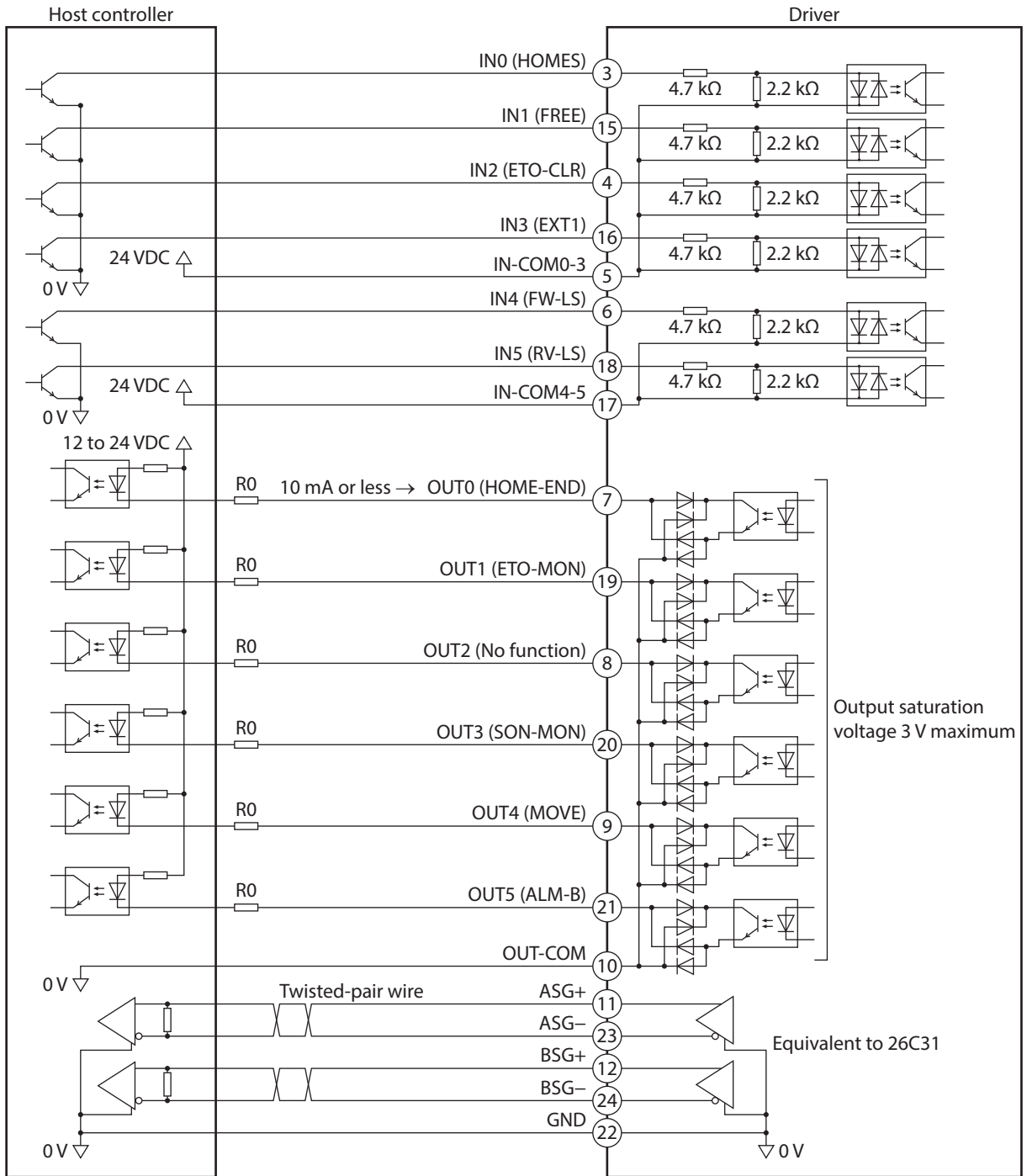

■ Connection example with a current source output circuit

Values in parentheses () in the figure are initial values.

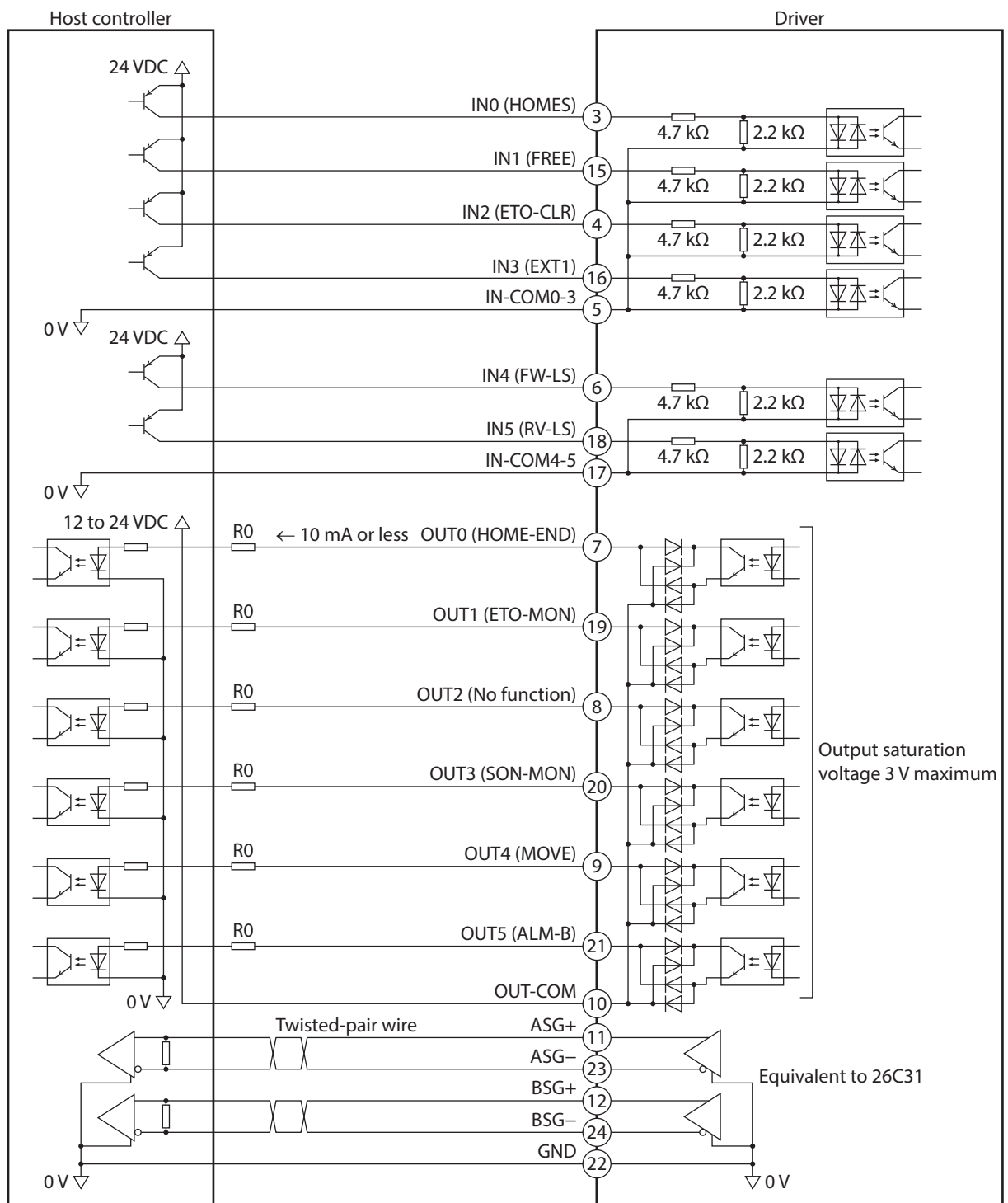

3-2 Remote I/O

Remote I/O is I/O to be accessed via EtherCAT.

■ Assignment to input signals

Use parameters to assign the input signals to R-IN0 to R-IN15 of remote I/O. Refer to "2-1 Input signals list" on p.30 for input signals that can be assigned.

Remote I/O signal name	Initial value	Remote I/O signal name	Initial value
R-IN0	No function	R-IN8	No function
R-IN1	No function	R-IN9	No function
R-IN2	No function	R-IN10	No function
R-IN3	No function	R-IN11	No function
R-IN4	No function	R-IN12	No function
R-IN5	No function	R-IN13	No function
R-IN6	No function	R-IN14	No function
R-IN7	No function	R-IN15	No function

● Related parameters

MEXE02 code	Name	Description	Setting range	Initial value
p8	R-IN0 input function	Selects an input signal to be assigned to R-IN.	Input signals list ⇒ p.30	0: No function
	R-IN1 input function			0: No function
	R-IN2 input function			0: No function
	R-IN3 input function			0: No function
	R-IN4 input function			0: No function
	R-IN5 input function			0: No function
	R-IN6 input function			0: No function
	R-IN7 input function			0: No function
	R-IN8 input function			0: No function
	R-IN9 input function			0: No function
	R-IN10 input function			0: No function
	R-IN11 input function			0: No function
	R-IN12 input function			0: No function
	R-IN13 input function			0: No function
	R-IN14 input function			0: No function
	R-IN15 input function			0: No function



- When the same input signal is assigned to multiple input terminals, the function will be executed if any of the terminals becomes active.
- When the HMI input is not assigned to an input terminal, this input will always be in an ON state. If it is assigned to both direct I/O and remote I/O, the function will be executed only when both of them are turned ON.

■ Assignment to output signals

Use parameters to assign the output signals to R-OUT0 to R-OUT15 of remote I/O.
Refer to "2-2 Output signals list" on p.31 for output signals that can be assigned.

Remote I/O signal name	Initial value	Remote I/O signal name	Initial value
R-OUT0	FW-LS_R	R-OUT8	SYS-BSY
R-OUT1	RV-LS_R	R-OUT9	AREA0
R-OUT2	ZSG	R-OUT10	AREA1
R-OUT3	No function	R-OUT11	AREA2
R-OUT4	HOME-END	R-OUT12	No function
R-OUT5	DCMD-RDY	R-OUT13	MOVE
R-OUT6	INFO	R-OUT14	IN-POS
R-OUT7	ALM-A	R-OUT15	TLC

● Related parameters

MEXE02 code	Name	Description	Setting range	Initial value
p8	R-OUT0 output function	Selects an output signal to be assigned to R-OUT.	Output signals list ⇒ p.31	28: FW-LS_R
	R-OUT1 output function			29: RV-LS_R
	R-OUT2 output function			155: ZSG
	R-OUT3 output function			0: No function
	R-OUT4 output function			144: HOME-END
	R-OUT5 output function			204: DCMD-RDY
	R-OUT6 output function			135: INFO
	R-OUT7 output function			129: ALM-A
	R-OUT8 output function			136: SYS-BSY
	R-OUT9 output function			160: AREA0
	R-OUT10 output function			161: AREA1
	R-OUT11 output function			162: AREA2
	R-OUT12 output function			0: No function
	R-OUT13 output function			134: MOVE
	R-OUT14 output function			138: IN-POS
	R-OUT15 output function			140: TLC

4 Input signals

4-1 Operation control

■ Excitation switching signal

This signal is used to switch the motor excitation state between excitation and non-excitation.

● FREE input

Turning the FREE input ON will shut off the motor current and put the motor in a non-excitation state. The output shaft can be rotated manually since the holding force of the motor is lost. In the case of an electromagnetic brake motor, the electromagnetic brake is also in a state of releasing the motor shaft.



When a load is installed vertically, do not turn the FREE input ON. The motor will lose its holding force and a load may fall.

When the motor is in an excitation state

1. When the FREE input is turned ON, the READY output is turned OFF to put the motor in a non-excitation state.
2. When the FREE input is turned OFF, the motor goes into an excitation state to turn the READY output ON.

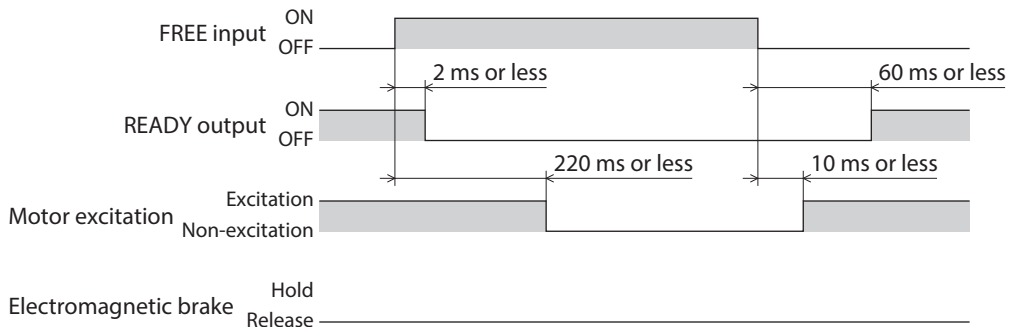
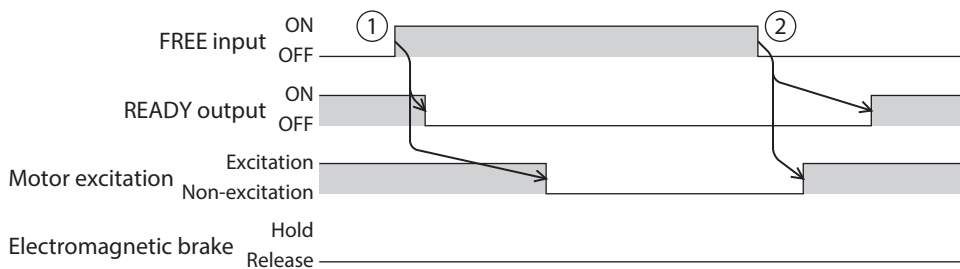

When the motor is in a non-excitation state

1. When the FREE input is turned ON, the electromagnetic brake is in a state of releasing the motor shaft.
2. When the FREE input is turned OFF, the electromagnetic brake is in a state of holding the motor shaft.

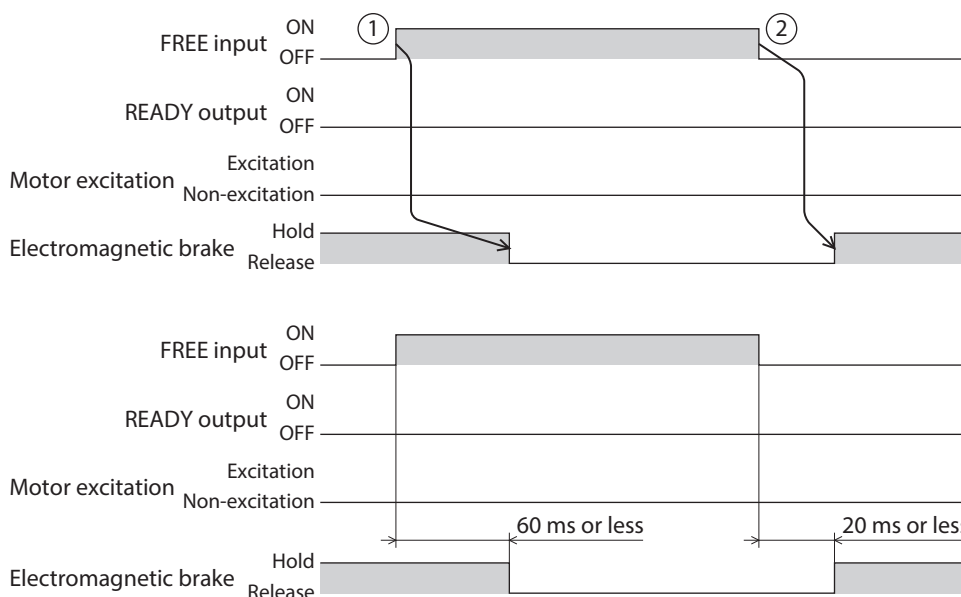

■ Operation stop signals

These signals are used to stop the motor operation. The IN-POS output is not turned ON even if an operation stop signal is turned ON.

● CLR input

Turning the CLR input ON will clear the position deviation counter and set the position deviation between the command position and the feedback position to zero. The motor immediately stops at the present feedback position when it is operating. The remaining travel amount is cleared.

1. When the CLR input is turned ON during operation, the motor stops and the position deviation is also cleared.
2. When the CLR input is turned OFF, the READY output is turned ON.

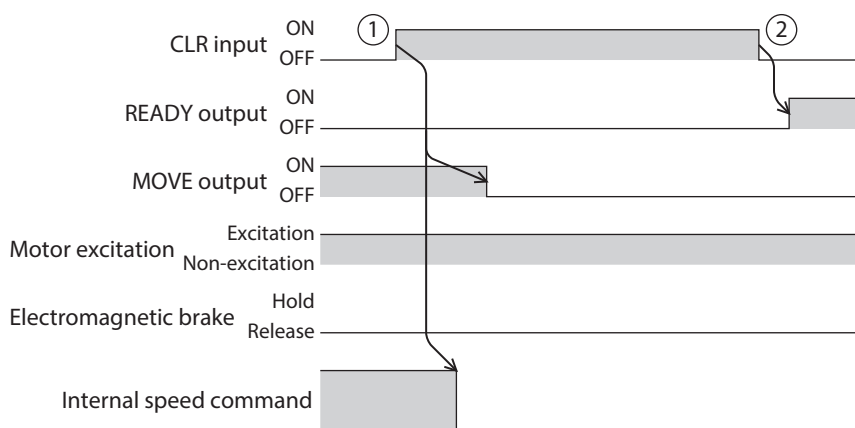

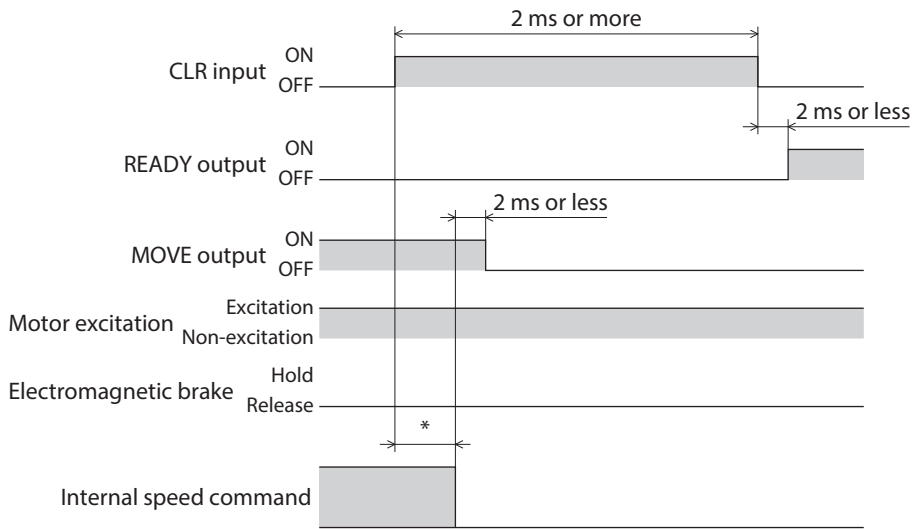

* It varies depending on the driving condition.

● **STOP input**

Turning the STOP input ON will stop the operation according to the setting of the "STOP input action" parameter. When the operation is stopped, the remaining travel amount is cleared.

Related parameter

MEXE02 code	Name	Description	Setting range	Initial value
p5	STOP input action	Sets how to stop the motor when the STOP input is turned ON.	0: Immediate stop 3: Deceleration stop	3

When the STOP input action is set to "Deceleration stop" (when the motor stops while the STOP input is ON)

1. When the STOP input is turned ON during operation, the motor starts the stopping movement.
2. When the STOP input is turned OFF, the READY output is turned ON.

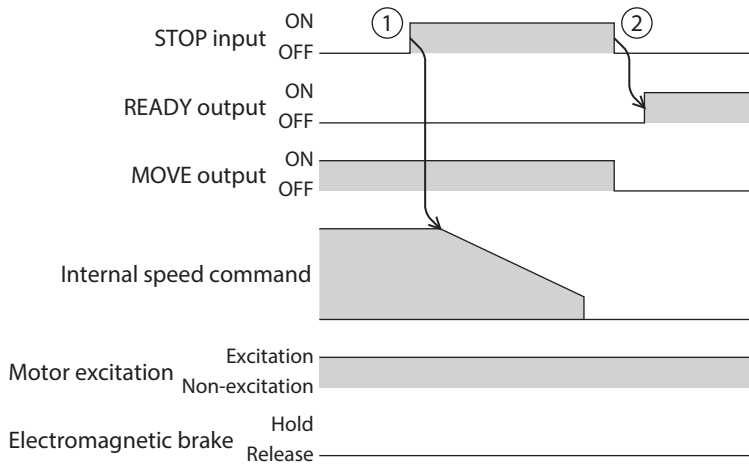

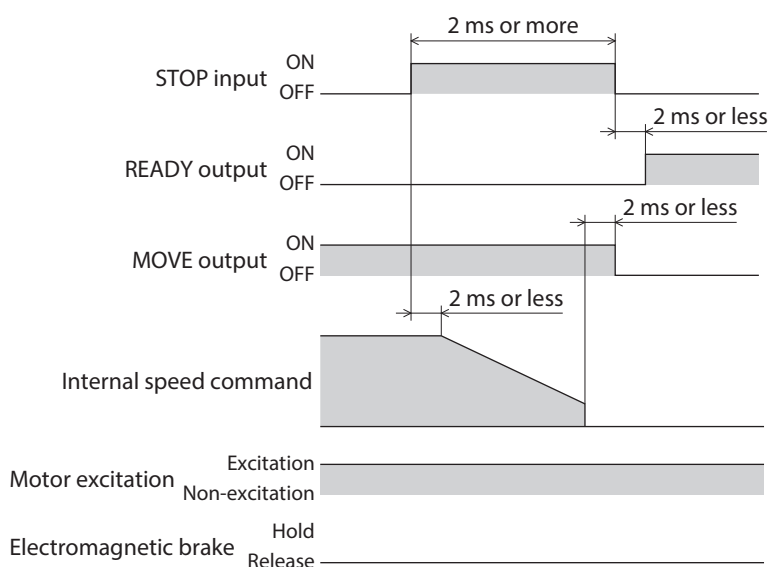

When the STOP input action is set to "Deceleration stop" (when the motor does not stop while the STOP input is ON)

1. When the STOP input is turned ON during operation, the motor starts the stopping movement. Even after the STOP input is turned OFF, the motor continues the deceleration operation until it stops.
2. When the motor stops, the READY output is turned ON.

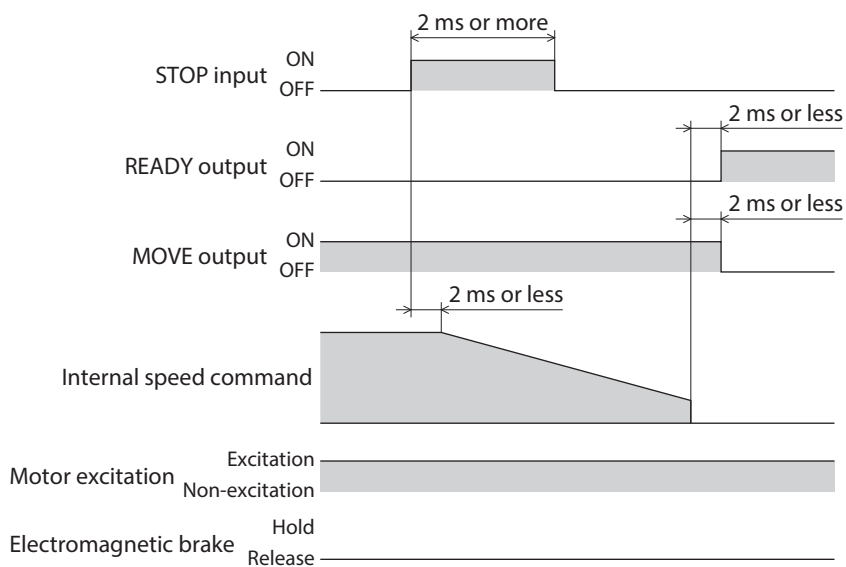

When the STOP input action is set to "Immediate stop"

1. If the STOP input is turned ON during operation, the motor stops at the command position at the time the ON state of the STOP input is detected.
2. When the STOP input is turned OFF, the READY output is turned ON.

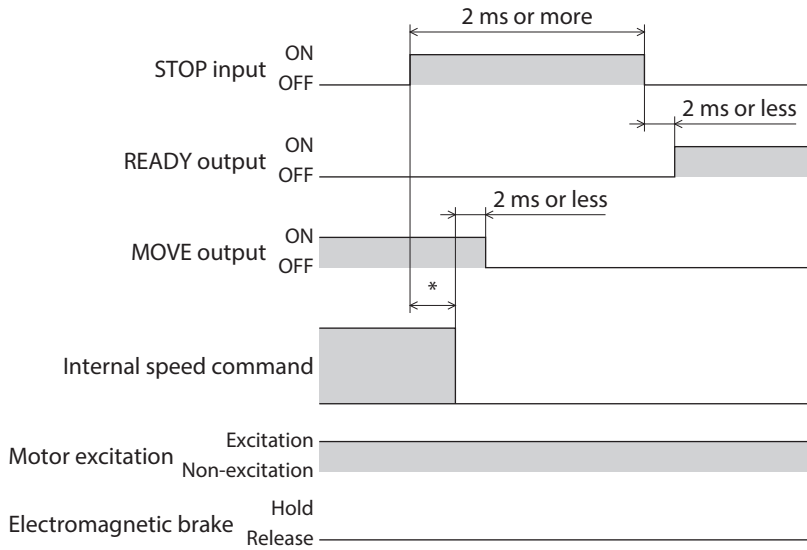

* It varies depending on the driving condition.

● **FW-BLK input, RV-BLK input**

Turning the FW-BLK input or the RV-BLK input ON will stop the operation according to the setting of the "FW-BLK/RV-BLK input action" parameter. Turning the FW-BLK input ON will stop the operation in the forward direction, and turning the RV-BLK input ON will stop the operation in the reverse direction. When the operation is stopped, the remaining travel amount is cleared. While an input that has stopped the operation is ON, the motor will not operate even if an operation start signal to operate in the same direction as the stop signal is input. An operation start signal in the opposite direction can be used for operation.

Related parameter

MEXE02 code	Name	Description	Setting range	Initial value
p5	FW-BLK/RV-BLK input action	Sets how to stop the motor when the FW-BLK input or the RV-BLK input is turned ON.	0: Immediate stop 1: Deceleration stop	0

memo The following information is generated when the FW-BLK input or the RV-BLK input is turned ON.

- When the FW-BLK input is turned ON: Forward operation prohibition
- When the RV-BLK input is turned ON: Reverse operation prohibition

When the FW-BLK/RV-BLK input action is set to "Deceleration stop" (when the motor stops while the FW-BLK input is ON)

1. When the FW-BLK input is turned ON during operation in the forward direction, the motor starts the stopping movement.
2. When the operation is stopped, the READY output is turned ON.
3. If an operation start signal in the reverse direction is input while the FW-BLK input is ON, the READY output is turned OFF to start operation.

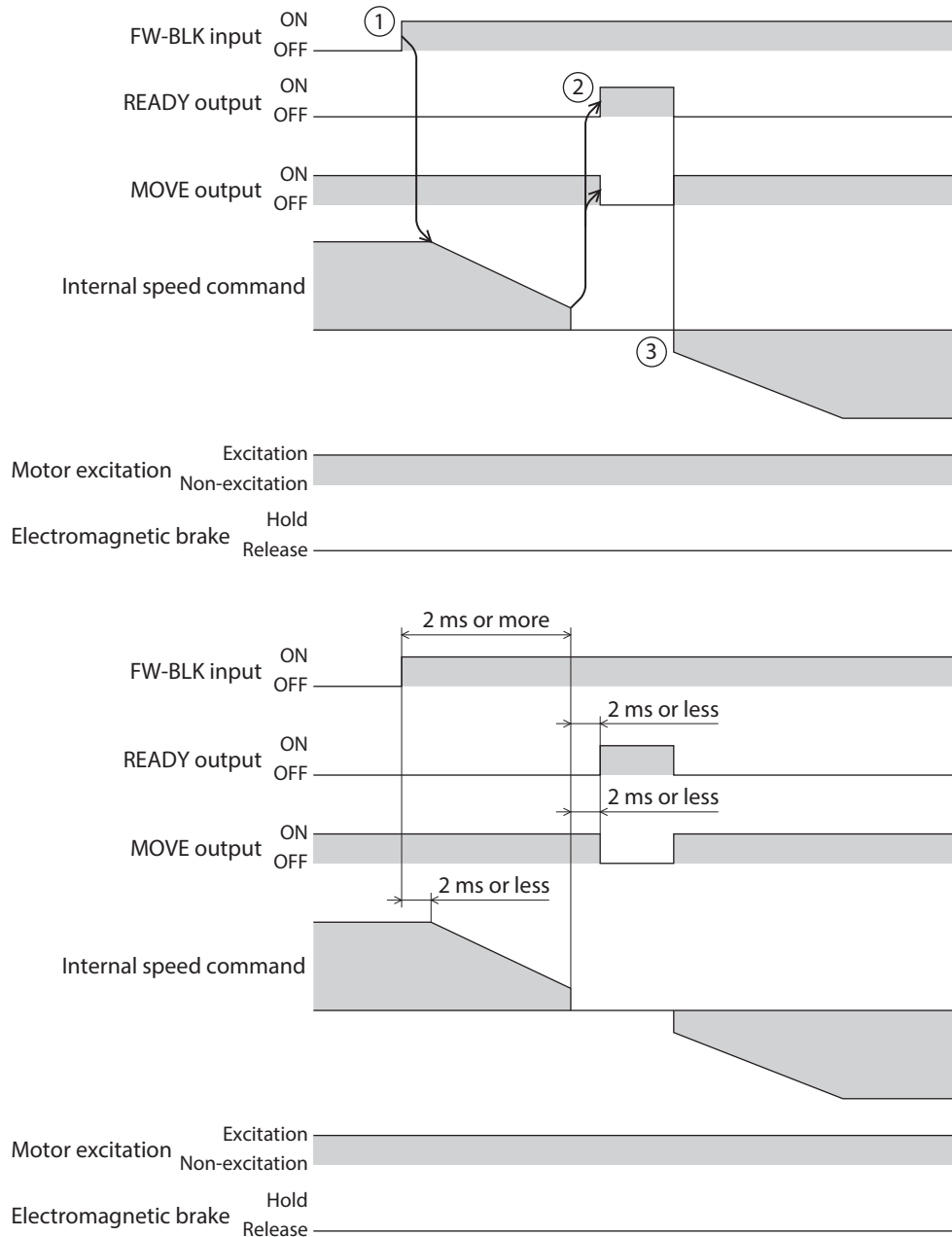

**When the FW-BLK/RV-BLK input action is set to "Deceleration stop"
(when the motor does not stop while the FW-BLK input is ON)**

1. When the FW-BLK input is turned ON during operation in the forward direction, the motor starts the stopping movement.
2. Even after the FW-BLK input is turned OFF, the motor continues the deceleration operation until it stops. When the operation is stopped, the READY output is turned ON.

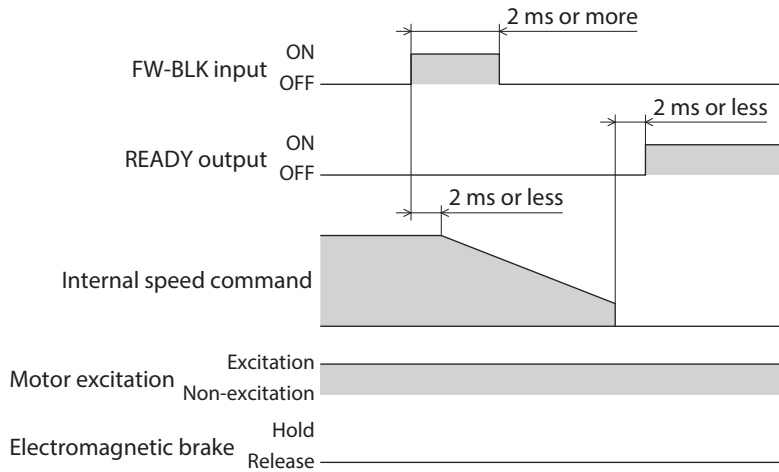

When the FW-BLK/RV-BLK input action is set to "Immediate stop"

1. If the FW-BLK input is turned ON during operation in the forward direction, the motor will stop.
2. The motor stops at the command position at the time when the ON status of the FW-BLK input was detected.

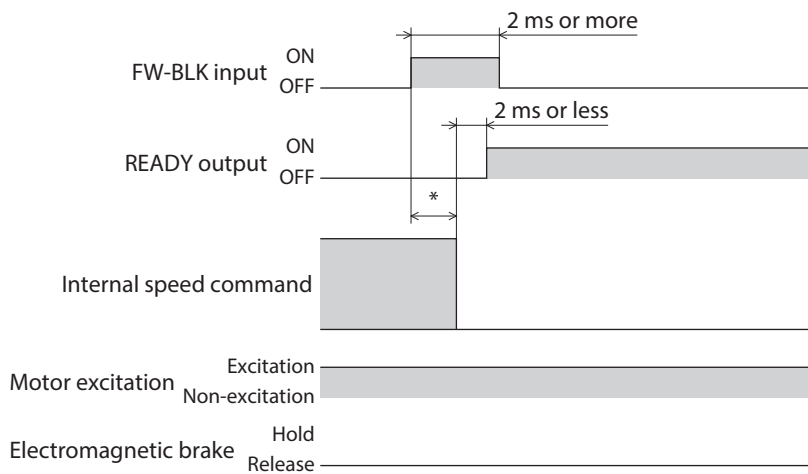

* It varies depending on the driving condition.

4-2 Position coordinate management

External sensor input signals

FW-LS input, RV-LS input

These are input signals from the limit sensors. The FW-LS input is a sensor in the forward direction and the RV-LS input is that in the reverse direction.

- Return-to-home:
When the FW-LS input or the RV-LS input is detected, return-to-home operation is performed according to the setting of the "(HOME) Return-to-home mode" parameter.
- Other than return-to-home:
Detect the hardware overtravel to stop the motor. When the "FW-LS/RV-LS input action" parameter is set to "-1: Use as the sensor for return-to-home," the motor does not stop.

Related parameter

MEXE02 code	Name	Description	Setting range	Initial value
p5	FW-LS/RV-LS input action	Sets how to stop the motor when the FW-LS input or the RV-LS input is turned ON.	-1: Use as the sensor for return-to-home 0: Immediate stop 1: Deceleration stop 2: Immediate stop with alarm 3: Deceleration stop with alarm	2

HOMES input

This is an input signal from the mechanical home sensor when the "(HOME) Return-to-home mode" parameter is set to "1: 3-sensor" or "2: One-way rotation."

Related parameter

MEXE02 code	Name	Description	Setting range	Initial value
p3	(HOME) Return-to-home mode	Sets the return-to-home method.	0: 2-sensor 1: 3-sensor 2: One-way rotation	1

SLIT input

Connect when returning to the home using a sensor with slit.

When executing return-to-home operation, using the SLIT input concurrently can detect the home more accurately.

Coordinate preset signal

This signal is used to preset the mechanical home or the electrical home.

P-PRESET input

Turning the P-PRESET input ON can rewrite the command position and the feedback position to the value set in the "Preset position" parameter.

At the same time, they are written to the non-volatile memory.

However, position preset cannot be executed while the motor is in operation.

Note Even if the motor is stopped, position preset cannot be executed while the TLC output is ON.

The INFO-PR-REQ output is turned ON while position preset is executed. When position preset is completed, the HOME-END output is turned ON.

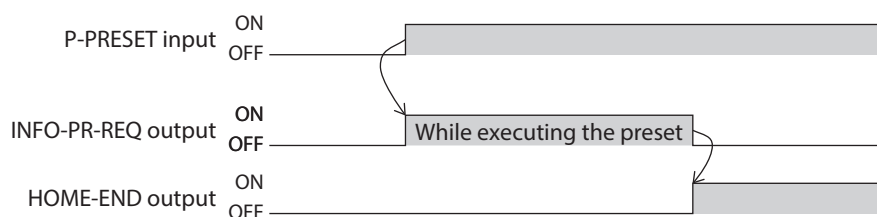

4-3 Management of driver

■ Status release signals

These signals are used to release the signal or status that is not released automatically.

● ALM-RST input

If an alarm is generated, the motor will stop. At this time, turning the ALM-RST input from OFF to ON will reset the alarm (the alarm will be reset at the ON edge of the ALM-RST input). Be sure to remove the cause of the alarm and ensure safety before resetting the alarm.

Note that some alarms cannot be reset with the ALM-RST input.

Refer to "1-4 Alarm list" on p.198 for alarms.

● LAT-CLR input

Turning the LAT-CLR input ON will clear the latch status.

● INFO-CLR input

This signal is enabled when the "Information auto clear" parameter is set to "0: Disable (not turned OFF automatically)."

Turning the INFO-CLR input ON will clear the information status.

■ Driver function change signals

● HMI input

Turning the HMI input ON will release the function limitation of the **MEXE02** software. Turning it OFF will limit the function.

The functions to be limited are shown below.

- I/O test
- Remote operation
- Writing of operation data and parameters
- [Restore to factory settings] under the [Communication] menu

Note

- When the HMI input is not assigned to direct I/O or remote I/O, this input will always be in an ON state. If it is assigned to both direct I/O and remote I/O, the function will be executed only when both of them are turned ON.
- When the HMI input is assigned to the DIN input function, do not set the "1 shot signal" parameter to "Enable."

● TRQ-LMT input

Turning the TRQ-LMT input ON will limit the torque.

● SPD-LMT input

Turning the SPD-LMT input ON will limit the operating speed.

Related parameters

MEXE02 code	Name	Description	Setting range	Initial value
p5	SPD-LMT speed limit type selection	Selects the setting method of the speed limit value.	0: Ratio 1: Value	0
	SPD-LMT speed limit ratio	Sets the percentage of the speed limit based on "Operating speed" of the operation data being 100 %. This is enabled when the "SPD-LMT speed limit type selection" parameter is set to "0: Ratio."	1 to 100 %	50
	SPD-LMT speed limit value	Sets the speed limit value as "Value." This is enabled when the "SPD-LMT speed limit type selection" parameter is set to "1: Value."	1 to 4,000,000 Hz	1,000

5 Output signals

5-1 Management of driver

■ Driver status indication signals

● ALM-A output, ALM-B output

If an alarm is generated, the ALM-A output is turned ON and the ALM-B output is turned OFF. At the same time, the PWR/ALM LED on the driver will blink in red, and the motor will stop. The motor goes into a non-excitation state after it stops.

The ALM-A output is normally open and the ALM-B output is normally closed.

● SYS-RDY output

After the control power supply is turned on, when output signals are ready to operate ON-OFF and signals are enabled to input, the SYS-RDY output is turned ON.

● INFO output

If information is generated, the INFO output is turned ON.

Related parameters

MEXE02 code	Name	Description	Setting range	Initial value
p4	Information auto clear	When the cause of information is eliminated, the INFO output and the bit output of the corresponding information are turned OFF automatically.	0: Disable (not turned OFF automatically) 1: Enable (turned OFF automatically)	1
	Information LED condition	Sets the LED status when information is generated.	0: The LED does not blink 1: The LED blinks	1

● SYS-BSY output

The SYS-BSY output is turned ON while the driver executes the maintenance command.

● Output of information signals

If corresponding information is generated, each output signal is turned ON. Refer to "2-2 Information list" on p.207 for details about information.

■ Hardware status indication

● SON-MON output

The SON-MON output is turned ON while the motor is in an excitation state.

● MPS output

The MPS output is turned ON when the main power supply is turned on.

● MBC output

Use this signal when controlling the electromagnetic brake by the host controller.

The MBC output is turned ON when the electromagnetic brake releases the motor shaft, and OFF when it holds. Detect the ON-OFF status of the MBC output using the host controller, and control the electromagnetic brake.

● RG output

The RG output is turned ON when the driver enters a regeneration state due to an increase in the input voltage.

5-2 Management of operation

■ Operation status indication

● READY output

When the driver is ready to operate, the READY output is turned ON. Input the operation start command to the driver after the READY output is turned ON.

The READY output is turned ON when all of the following conditions are satisfied.

- The control power supply and the main power supply of the driver are turned on.
- The excitation command is input from the EtherCAT MainDevice.
- The FREE input is OFF.
- The STOP input is OFF.
- The CLR input is OFF.
- An alarm is not being generated.
- The motor is not operated.
- The following monitors or menus are not executed with the **MEXE02** software.
 - Remote operation
 - I/O test
 - Data writing
 - Restore to factory settings
- The following commands are not executed via EtherCAT.
 - Configuration
 - All data batch initialization
 - Read batch NV memory
 - Write batch NV memory
 - Read from backup
 - Write to backup

● MOVE output

The MOVE output is turned ON while the motor operates.

Related parameter

MEXE02 code	Name	Description	Setting range	Initial value
p5	MOVE minimum ON time	Sets the minimum time during which the MOVE output remains ON.	0 to 255 ms	0

● OPE-BSY output

The OPE-BSY output is turned ON while the driver executes internal oscillation.

● IN-POS output

After positioning operation is completed, when the motor has converged in a position of the "Position window" parameter against the command position, the IN-POS output is turned ON.

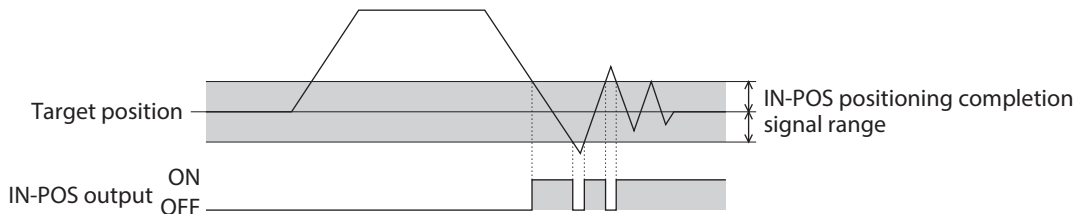

Related parameters

MEXE02 code	Name	Description	Setting range	Initial value
p1	Position window	This is used to set the output range of the positioning completion output (IN-POS). It is the same as the "IN-POS positioning completion signal range" parameter of the AZ Series. In the Profile position mode (PP), after positioning operation is properly completed, the Target Reached (6041h: bit10) of the Statusword changes to 1 when the feedback position has converged in a range of the Position window parameter against the Position demand value (command position). The IN-POS output range can be offset by the "IN-POS positioning completion signal offset" parameter.	1 to 180 (1=0.1 °)	18
p5	IN-POS positioning completion signal offset	Sets the amount of offset from the target position.	-18 to 18 (1=0.1 °)	0



When continuous operation is stopped, or when operation is interrupted by the STOP input or other operation stop signals, the IN-POS output is not turned ON.

- **TLC output**

The TLC output is turned ON when the output torque reaches the maximum output torque or the torque limiting value.

- **VA output**

The VA output is turned ON when the operating speed reaches the target speed. The judgment criterion can be set using the "VA mode selection" parameter.

When the "VA mode selection" parameter is set to "0: Actual speed attainment (speed at feedback position)"

When the motor feedback speed falls in the setting range of the "VA detection speed range" parameter with the command speed as a center, the VA output is turned ON.

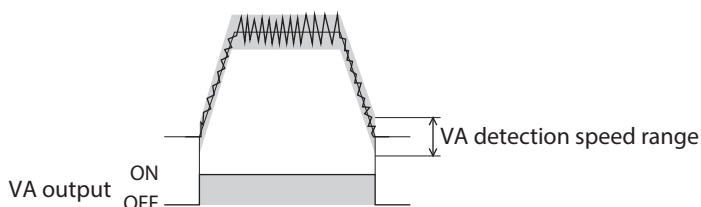

When the "VA mode selection" parameter is set to "1: Speed at command position (only internal profile)"

When the motor command speed matches the target speed, the VA output is turned ON.

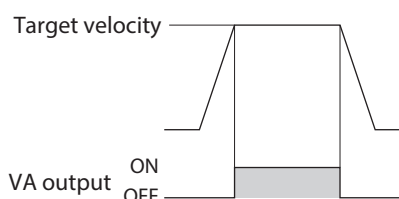

When the "VA mode selection" parameter is set to "2: Speed at feedback position & command position (only internal profile)"

When the motor feedback speed falls in the setting range of the "VA detection speed range" parameter with the target speed as the center, the VA output is turned ON.

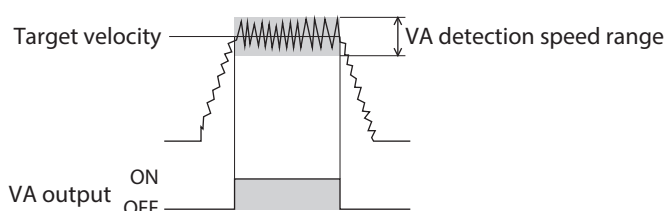

Related parameters

MEXE02 code	Name	Description	Setting range	Initial value
p5	VA mode selection	Selects the judgment criterion of the VA output.	0: Actual speed attainment (speed at feedback position) 1: Speed at command position (only internal profile) 2: Speed at feedback position & command position (only internal profile)	2
	VA detection speed range	Sets the allowable range of the judgment criterion for the feedback speed when the "VA mode selection" parameter is set to "0: Actual speed attainment (speed at feedback position)" or "2: Speed at feedback position & command position (only internal profile)."	1 to 200 r/min	30

- **TRQ-LMTD output**

This signal is enabled when the torque limiting is being performed. When the motor output torque reaches the torque limiting value, the TRQ-LMTD output is turned ON. Refer to p.131 for the torque limiting function.

- **SPD-LMTD output**

This signal is enabled when the speed limiting is being performed. If the operating speed increases equal to or higher than the value set in the "SPD-LMT speed limit ratio" parameter or the "SPD-LMT speed limit value" parameter, it is limited to turn the SPD-LMTD output ON.

Related parameters

MEXE02 code	Name	Description	Setting range	Initial value
p5	SPD-LMT speed limit type selection	Selects the setting method of the speed limit value.	0: Ratio 1: Value	0
	SPD-LMT speed limit ratio	Sets the percentage of the speed to be limited based on "Operating speed" of the operation data being 100 %. This is enabled when the "SPD-LMT speed limit type selection" parameter is set to "0: Ratio."	1 to 100 %	50
	SPD-LMT speed limit value	Sets the speed limit value as "Value." This is enabled when the "SPD-LMT speed limit type selection" parameter is set to "1: Value."	1 to 4,000,000 Hz	1,000

- **HOME-END output**

The HOME-END output is turned ON in the following cases.

- When high-speed return-to-home operation is completed.
- When return-to-home operation is completed.
- When position preset is executed and coordinates are set.

This signal is turned OFF in the following cases.

- When the control power supply is turned on.
- When operation is started.

● ZV output

When the feedback speed is equal to or less than the speed set in the "ZV detection speed range" parameter with the operating speed 0 r/min as the center, the ZV output is turned ON.

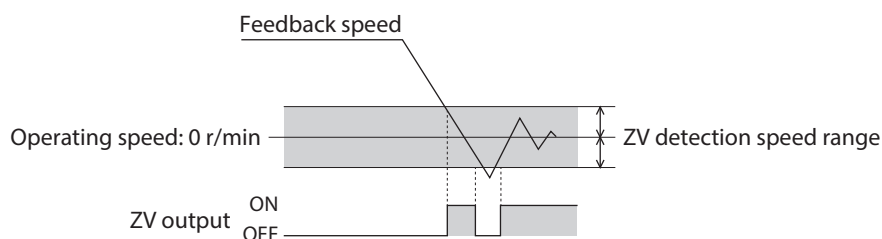

Related parameter

MEXE02 code	Name	Description	Setting range	Initial value
p5	ZV detection speed range	Sets the output range (one side) of the ZV output with the operating speed 0 r/min as the center.	0 to 200 r/min	15

● OL-DTCT output

The OL-DTCT output is turned ON when the output torque reaches the torque to detect the overload alarm. Refer to p.203 for detection of the overload alarm.

● DCMD-FULL output

The DCMD-FULL output is turned ON when data is being written to the buffer area.

● DCMD-RDY output

This signal is output when the driver is ready to operate.

The DCMD-RDY output is turned ON when all of the following conditions are satisfied.

- The control power supply and the main power supply of the driver are turned on.
- The excitation command is input from the EtherCAT MainDevice.
- The STOP input is OFF.
- The CLR input is OFF.
- An alarm is not being generated.
- Return-to-home operation is not executed.
- The following monitors or menus are not executed with the **MEXE02** software.
 - Remote operation
 - I/O test
 - Data writing
 - Restore to factory settings
- The following commands are not executed via EtherCAT.
 - Configuration
 - All data batch initialization
 - Read batch NV memory
 - Write batch NV memory
 - Read from backup
 - Write to backup

■ Motor position indication

These signals are output according to the motor position.

● ZSG output

This signal is turned ON every time the feedback position of the motor increases by one round from the position having preset by "ZSG preset" of the **MEXE02** software or the maintenance command "ZSG-PRESET" of EtherCAT.

Related parameter

MEXE02 code	Name	Description	Setting range	Initial value
p5	ZSG signal width	Sets the output range of the ZSG output.	1 to 1,800 (1=0.1 °)	18



Set the "ZSG signal width" parameter according to the operating speed so that the ZSG output is output at least 1 ms.

● RND-ZERO output

If the position set with the "RND-ZERO signal source" parameter is in the home position of the wrap range when the "Wrap (RND) setting" parameter is set to "1: Enable," the RND-ZERO output is turned ON.

Using the "The number of the RND-ZERO output in wrap range" parameter can output the signal for each interval by equally dividing the wrap range by a desired number of divisions.

Related parameters

MEXE02 code	Name	Description	Setting range	Initial value
p3	The number of the RND-ZERO output in wrap range	Sets the number of times to turn the RND-ZERO output ON in the wrap range.	1 to 536,870,911 divisions	1
p5	RND-ZERO signal width	Sets the output width of the RND-ZERO output.	1 to 10,000 steps	10
	RND-ZERO signal source	Sets the criterion of the RND-ZERO output.	0: Based on feedback position 1: Based on command position	0

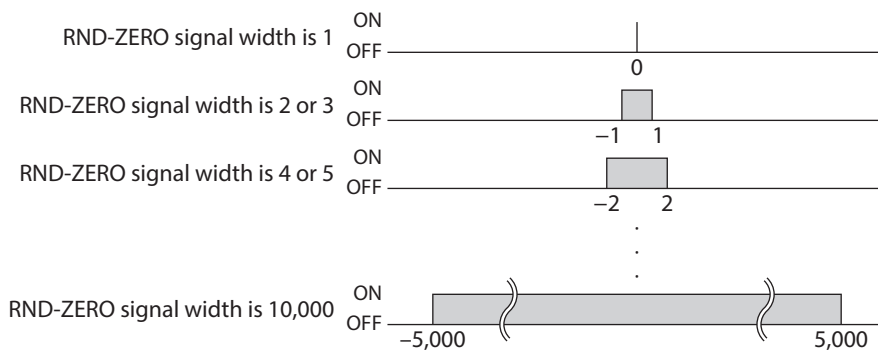

● AREA0 to AREA7 outputs

The AREA outputs are turned ON when the motor is within the set area.
They are turned ON when the motor is within the area even if the motor stops.

Related parameters

MEXE02 code	Name	Description	Setting range	Initial value
p5	AREA0 positive direction position/ offset to AREA7 positive direction position/ offset	Sets the positive direction position or offset from the target position for the AREA output.	-2,147,483,648 to 2,147,483,647 steps	0
	AREA0 negative direction position/ detection range to AREA7 negative direction position/ detection range	Sets the negative direction position or distance from the offset position for the AREA output.		0
	AREA0 range setting mode to AREA7 range setting mode	Sets the range setting mode for the AREA output.	0: Range setting with absolute value 1: Offset/width setting from the target position	0
	AREA0 positioning standard to AREA7 positioning standard	Sets the judgment criterion of the position for AREA output.	0: Based on feedback position 1: Based on command position	0

When the "AREA range setting mode" parameter is "0: Range setting with absolute value"

- When a value in the "AREA positive direction position/ offset" parameter is larger than that in the "AREA negative direction position/ detection range" parameter
When the motor position is equal to or larger than a value in the "AREA negative direction position/ detection range" parameter or equal to or smaller than that in the "AREA positive direction position/ offset" parameter, the AREA output is turned ON.

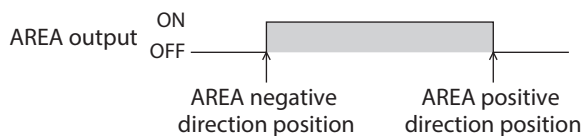

- When a value in the "AREA positive direction position/ offset" parameter is smaller than that in the "AREA negative direction position/ detection range" parameter
When the motor position is equal to or smaller than a value in the "AREA positive direction position/ offset" parameter or equal to or larger than that in the "AREA negative direction position/ detection range" parameter, the AREA output is turned ON.

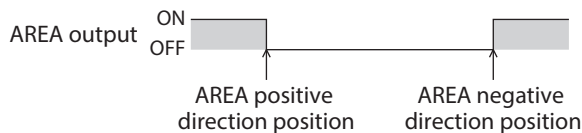

- When a value in the "AREA positive direction position/ offset" parameter is equal to that in the "AREA negative direction position/ detection range" parameter
When the motor position is equal to values in the "AREA negative direction position/ detection range" parameter and the "AREA positive direction position/ offset" parameter, the AREA output is turned ON.

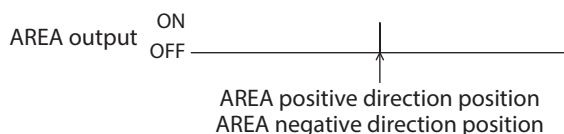

When the "AREA range setting mode" parameter is "1: Offset/width setting from the target position"

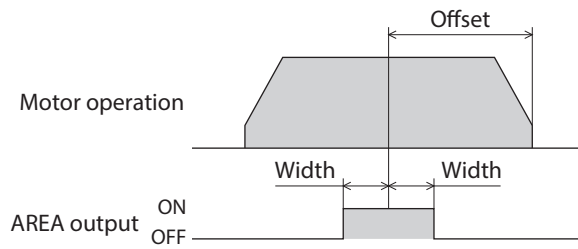

- **FW-SLS output, RV-SLS output**

If the command position exceeds the range set in the "Software limit" parameter when the "Software overtravel" parameter is set to other than "-1 Disable," the FW-SLS output or the RV-SLS output is turned ON.

- **RND-OVF output**

ON-OFF of the RND-OVF output is inverted when the wrap range is exceeded.

■ Coordinate status indication

- **ABSPEN output**

The ABSPEN output is turned ON when the coordinates are set.

- **PRST-DIS output**

The PRST-DIS output is turned ON when the home is required to set again.

If the "Preset position" parameter is set to other than "0," the PRST-DIS output is turned ON when the resolution is changed after position preset or return-to-home operation is performed.

When the PRST-DIS output has been turned ON, perform position preset or return-to-home operation to set the home.



If the resolution is changed in a state where the "Preset position" parameter is set to "0," coordinates are automatically set again. Therefore, the PRST-DIS output is not turned ON even if the resolution is changed.

- **PRST-STLD output**

The PRST-STLD output is turned ON when position preset is performed and the home information is stored in the ABZO sensor.

- **ORGN-STLD output**

Products such as motorized actuators whose home is set at the time of factory shipment are delivered in a state where the ORGN-STLD output is ON.

5-3 Response outputs

A response output is a signal to output the ON-OFF status of the corresponding input signal. The table below shows the correspondence between input signals and output signals.

Input signal	Output signal	Input signal	Output signal
FREE	FREE_R	R0	R0_R
CLR	CLR_R	R1	R1_R
STOP	STOP_R	R2	R2_R
ALM-RST	ALM-RST_R	R3	R3_R
P-PRESET	P-PRESET_R	R4	R4_R
ETO-CLR	ETO-CLR_R	R5	R5_R
LAT-CLR	LAT-CLR_R	R6	R6_R
INFO-CLR	INFO-CLR_R	R7	R7_R
HMI	HMI_R	R8	R8_R
TRQ-LMT	TRQ-LMT_R	R9	R9_R
SPD-LMT	SPD-LMT_R	R10	R10_R
FW-BLK	FW-BLK_R	R11	R11_R
RV-BLK	RV-BLK_R	R12	R12_R
FW-LS	FW-LS_R	R13	R13_R
RV-LS	RV-LS_R	R14	R14_R
HOMES	HOMES_R	R15	R15_R
SLIT	SLIT_R		

6 Timing chart

■ Power activation

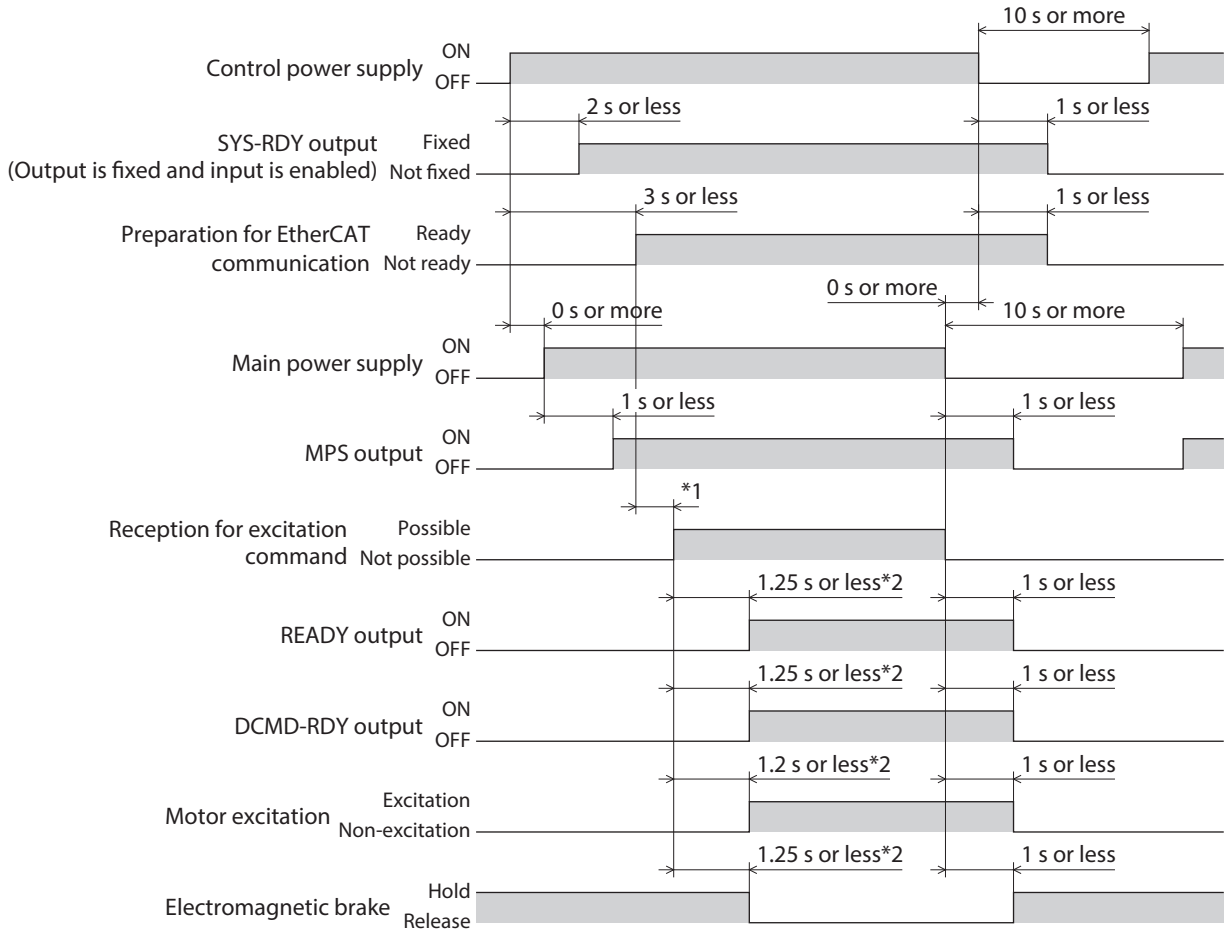

*1 It varies depending on the timing when the command is transitioned from the EtherCAT MainDevice.

*2 It indicates when the excitation command is received at the same time as the excitation command reception has changed to "Possible."

■ Electromagnetic brake

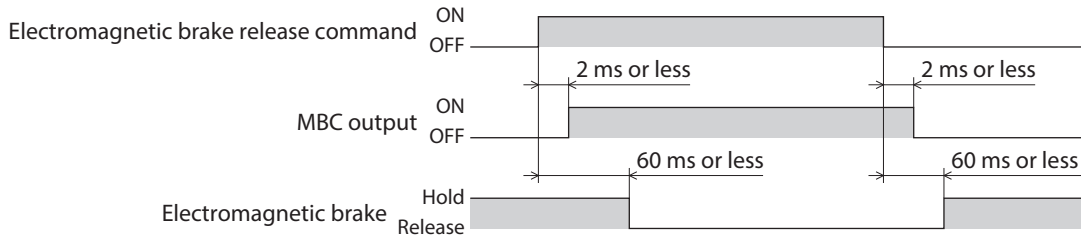

■ I/O signals (when the output is switched according to the ON edge of the input signal)

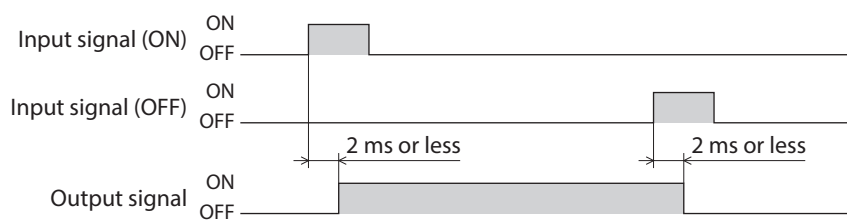

■ I/O signals (when the output is switched with the ON/OFF edge of the input signal)

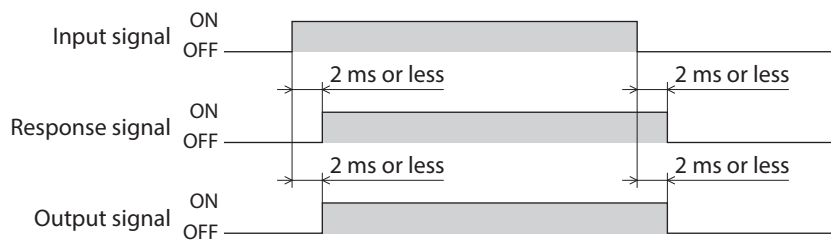

4 EtherCAT communication

This part explains how to control via EtherCAT communication.

◆ Table of contents

1	Guidance	63	4	Functions.....	104
2	Communication specifications	65	4-1	Touch probe.....	104
2-1	EtherCAT communication interface.....	65	4-2	Resolution	107
2-2	CiA402 drive profile	65	4-3	Wrap function	108
2-3	EtherCAT State Machine (ESM)	66	4-4	Maintenance commands	108
2-4	Process Data Objects (PDO)	66	4-5	Assignment of I/O functions.....	109
2-5	Service Data Objects (SDO).....	69	5	Coordinates management.....	119
2-6	Synchronous mode of EtherCAT	69	5-1	Overview of coordinates management.....	119
2-7	Distributed Clocks	70	5-2	Coordinate origin.....	122
2-8	Emergency message	70	5-3	Parameters related to ABZO sensor	123
3	Drive profile	71	5-4	Mechanism settings parameter.....	124
3-1	Drive state machine	71	5-5	Initial coordinate generation & wrap coordinate parameters	125
3-2	Operation modes.....	74	5-6	Mechanism limit.....	129
3-3	Cyclic synchronous position mode (CSP)	74	5-7	Mechanism protection	130
3-4	Profile position mode (PP).....	76	6	Torque limiting function	131
3-5	Cyclic synchronous velocity mode (CSV)	87	7	Saving parameters	132
3-6	Profile velocity mode (PV)	89			
3-7	Homing mode (HM).....	91			

■ Setting of data and parameters

Data and parameters described in “4 EtherCAT communication” can be set using the **MEXE02** software in addition to EtherCAT.

■ Notation rules

● Timing of the update

When a parameter is changed, the timing for updating the new value varies depending on the parameter. In this part, each update timing is represented in an alphabet.

Notation	Description
A	Recalculation and setup are immediately executed when the parameter is written.
B	Recalculation and setup are executed when the operation is stopped.
C	Recalculation and setup are executed after Configuration is executed or Write batch NV memory is executed to turn on the control power supply again.
D	Recalculation and setup are executed after Write batch NV memory is executed to turn on the control power supply again.

1 Guidance

If you are new to this product, read this chapter to understand the operating methods along with the operation flow. This is an example how to operate the motor via EtherCAT.

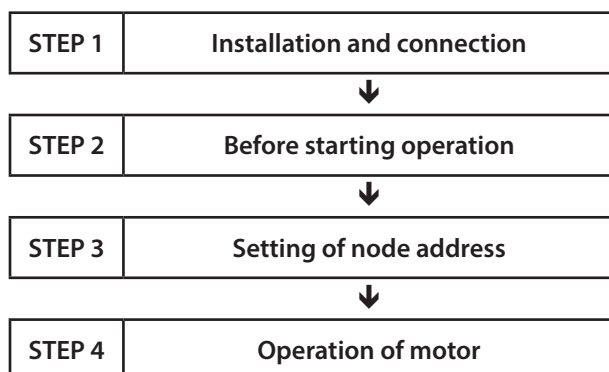

● **Operating conditions**

This operation is performed under the following conditions.

- Number of drivers connected: 1 unit
- Node address: 1

Note

- Before operating the motor, check the condition of the surrounding area to ensure safety.
- Before starting based on the guidance, import the ESI file to the setting tool of the EtherCAT MainDevice and register the system configuration in advance. The ESI file can be downloaded from Oriental Motor Website Download Page.

STEP 1 Check the installation and the connection.

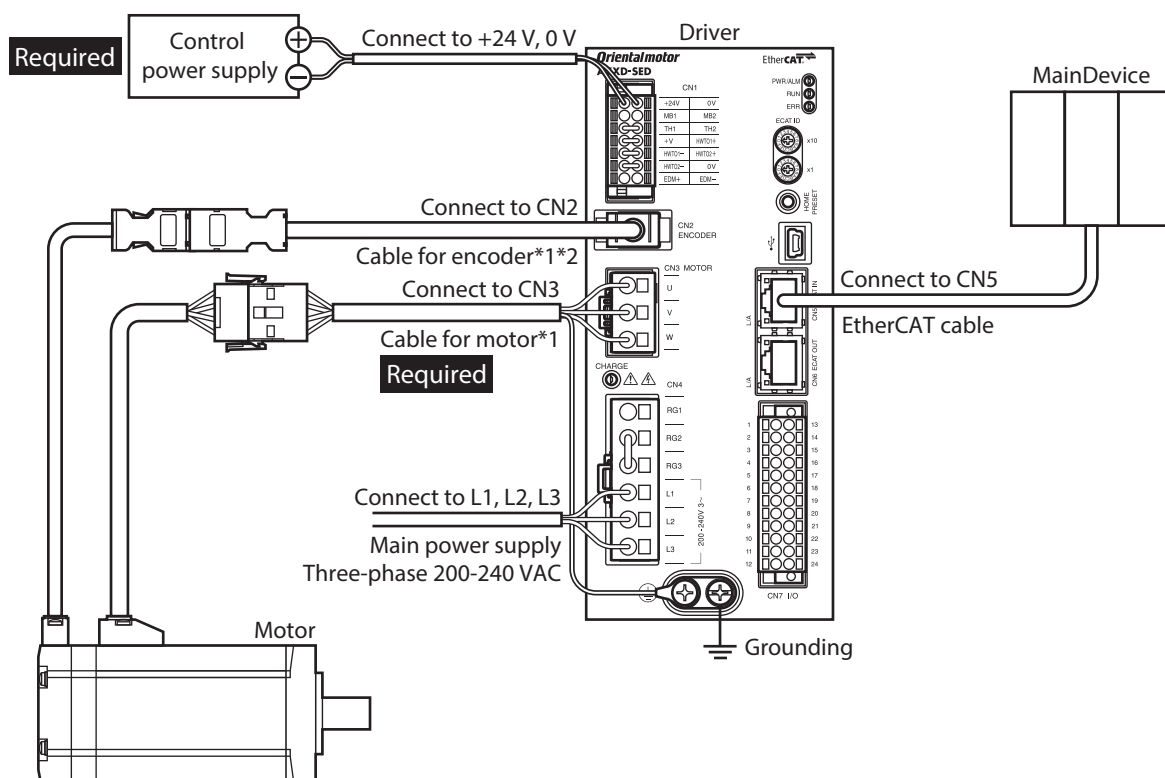

*1 Purchase is required separately.

*2 Use the cable for encoder when the length of the encoder cable of the motor is not sufficient.

STEP 2 Set a node address.

Set a node address using the node address setting switches (ECAT ID ×10, ×1) on the driver.

1. Set the node address setting switches as shown below.

Setting: 1 (×10: 0, ×1: 1)

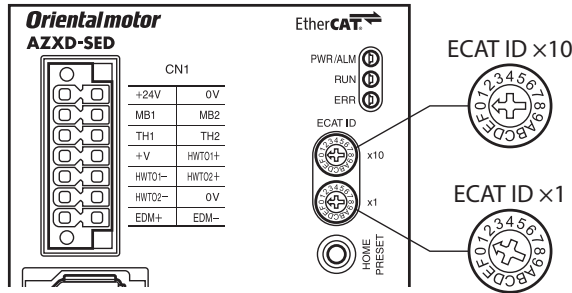

2. Turn on the control power supply again.

Note Be sure to turn off the control power supply of the driver before setting the switches. Setting the switches while the control power supply is on will not enable the new setting.

STEP 3 Operate the motor

Set the motor to an excitation state via EtherCAT to input the operation command.

STEP 4 Were you able to operate?

How did it go? Were you able to operate properly? If the motor does not operate, check the following points.

- Is the PWR/ALM LED blinking in red?
An alarm is being generated. Refer to p.196 for details.
- Are the power supply, the motor and the EtherCAT cable connected securely?
- Is the node address set correctly?
- Is the ERR LED blinking in red?
A communication error is being detected. Refer to the OPERATING MANUAL Hardware Edition for details.

2 Communication specifications

2-1 EtherCAT communication interface

Item	Description
Communications standards	IEC 61158 Type12
Physical layer/Protocol	100 BASE-TX (IEEE 802.3)
Transmission rate	100 Mbps
Communication cycle	<ul style="list-style-type: none"> • Free Run mode: 1 ms or more • Sync Manager 2 event synchronization mode: 1 ms or more • DC mode: 0.25 ms, 0.5 ms, 1 ms, 2 ms, 3 ms, 4 ms, 5 ms, 6 ms, 7 ms, 8 ms, 9 ms, 10 ms
Communication port / Connector	RJ45×2 (Shielded) ECAT IN: EtherCAT input ECAT OUT: EtherCAT output
Topology	Daisy chain (Up to 65,535 nodes)
Process data	Variable PDO mapping
Sync Manager	<ul style="list-style-type: none"> • SM0: Mailbox output • SM1: Mailbox input • SM2: Process data output • SM3: Process data input
Mailbox (CoE)	<ul style="list-style-type: none"> • Emergency message • SDO request • SDO response • SDO information
Synchronization mode	<ul style="list-style-type: none"> • Free Run mode (Asynchronous) • Sync Manager 2 event synchronization mode • DC mode (SYNC0 event synchronization)
Device profile	IEC 61800-7 CiA402 drive profile

2-2 CiA402 drive profile

Item	Description
Modes of operation	<ul style="list-style-type: none"> • Profile position mode (PP) • Profile velocity mode (PV) • Homing mode (HM) • Cyclic synchronous position mode (CSP) • Cyclic synchronous velocity mode (CSV)
Function	Touch probe (position latch) function 2 inputs (EXT1, EXT2)

2-3 EtherCAT State Machine (ESM)

The EtherCAT State Machine (ESM) is controlled by the EtherCAT MainDevice.

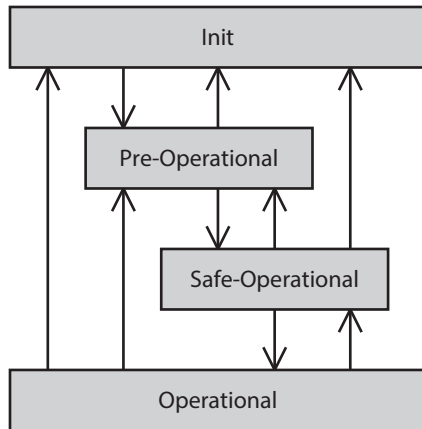

ESM State	SDO communication	Transmit PDO (TxPDO)	Receive PDO (RxPDO)	Status
Init	Not possible	Not possible	Not possible	During initialization. Communication cannot be performed.
Pre-Operational	Possible	Not possible	Not possible	The mailbox communication (SDO) can be performed. The process data communication (PDO) cannot be performed.
Safe-Operational	Possible	Possible	Not possible	The mailbox communication and transmit PDO can be performed. The status of the driver can be sent to the MainDevice in transmit PDO.
Operational	Possible	Possible	Possible	The mailbox communication, transmit PDO, and receive PDO can be performed. Commands can be sent from the MainDevice to the driver in PDO communication.

2-4 Process Data Objects (PDO)

Process Data Objects (PDO) are used in real-time data communication of EtherCAT.

There are two types of PDOs, transmit PDO (TxPDO) and receive PDO (RxPDO). Transmit PDO (TxPDO) is the data transmission from the driver to the MainDevice. Receive PDO (RxPDO) is the data reception from the MainDevice to the driver.

Contents, which are sent and received using PDO, are set by the PDO mapping object and the Sync Manager 2/Sync Manager 3 PDO assignment object.

PDO mapping is to set the PDO mapping object.

Sync Manager 2 PDO assignment and Sync Manager 3 PDO assignment are to set the PDO mapping object that performs communication actually.

The PDO mapping object is consisted of four bytes that are Index, Sub-index, and Length of assigned object. Only data of 08h (1 byte), 10h (2 bytes), and 20h (4 bytes) can be set in the data length.

Index	Sub-index	Data length
(2 bytes)	(1 byte)	(1 byte)

■ PDO mapping object

Up to 16 objects can be mapped in a single PDO.

Receive PDO mapping object		Transmit PDO mapping object	
Receive PDO	Index	Transmit PDO	Index
RxPDO1	1600h	TxPDO1	1A00h
RxPDO2	1601h	TxPDO2	1A01h

Objects to be mapped in PDO are as follows.

Objects of profile area	Objects of manufacturer-specific area
6000h to 67FFh	4000h to 4FFFh



The configuration of objects is as follows.

Index (Hex)	Object	Overview
1000h to 1FFFh	CoE Communication Area	CoE communication area
2000h to 3FFFh	Manufacturer-Specific Area	Not used
4000h to 4FFFh		Driver object
5000h to 5FFFh		Not used
6000h to 67FFh	Profile Area	Profile area

■ Sync Manager 2/Sync Manager 3 PDO assignment object

The SM (Sync Manager Channel) PDO assignment objects set the relationship between PDO and Sync Manager. The Sync Manager 2 PDO assignment (1C12h) is the assignment object dedicated to the receive PDO. The Sync Manager 3 PDO assignment (1C13h) is the assignment object dedicated to the transmit PDO. Objects of up to 64 bytes can be assigned.

■ Setting of PDO mapping object

PDO mapping can be changed when the ESM is Pre-Operational. Change the PDO mapping in the following steps.

1. Set the number of entries of the Sync Manager 2/Sync Manager 3 PDO assignment object to 0.
2. Set the number of entries of the PDO mapping object to 0.
3. Change the PDO mapping object.
4. Change the number of entries of the PDO mapping object to the number of objects mapped in Step 3.
5. Change the Sync Manager 2/Sync Manager 3 PDO assignment object.
6. Change the number of entries of the Sync Manager 2/Sync Manager 3 PDO assignment object to the number assigned in the step 5.

■ Example of PDO mapping

This section introduces an example of PDO mapping. Data of 2 bytes and 4 bytes are little-endian. Set the mapping of the PDO communication by selecting the PDO mapping object that actually communicates with the Sync Manager 2/Sync Manager 3 PDO assignment object.

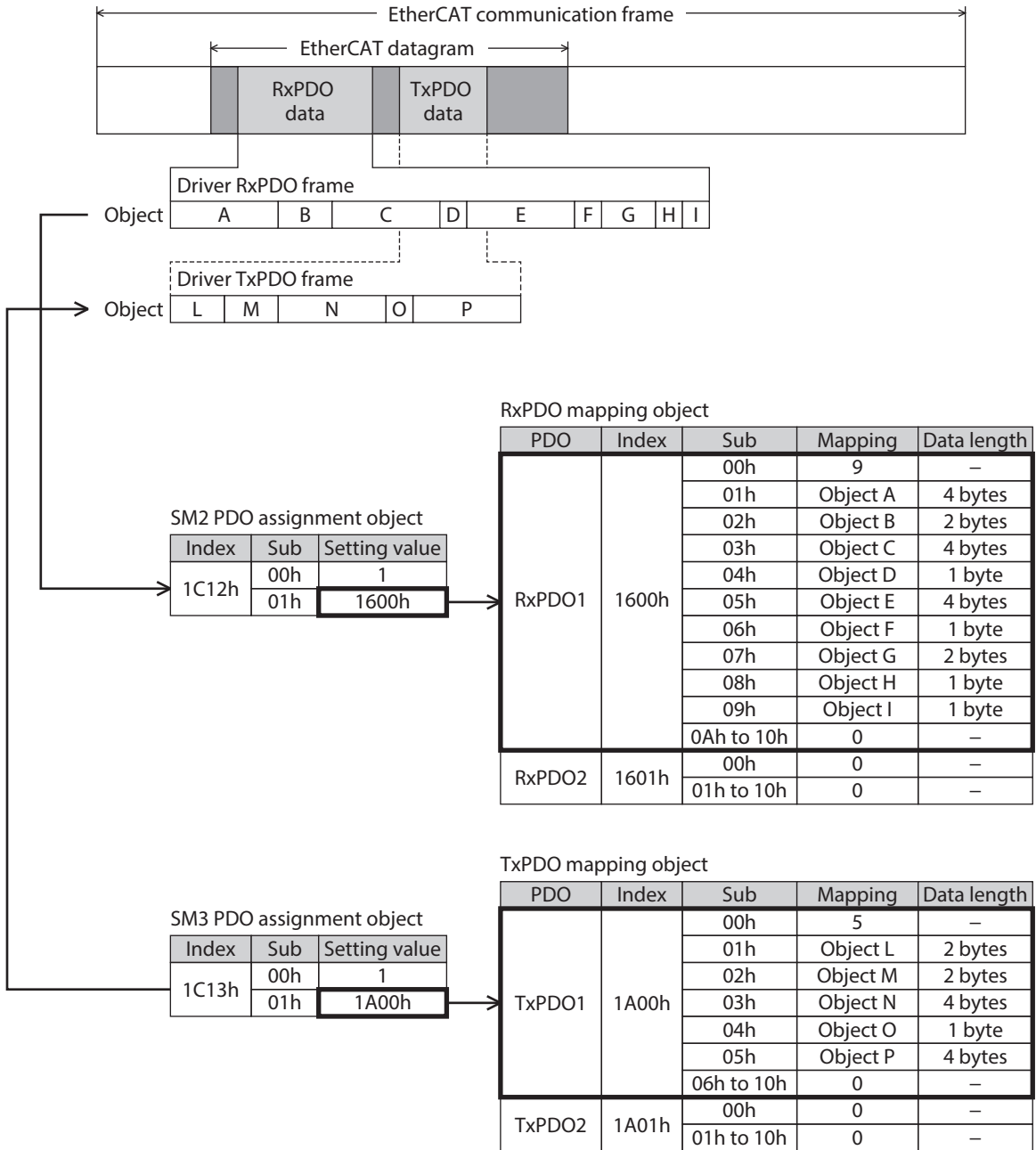

2-5 Service Data Objects (SDO)

Service Data Objects (SDO) are used when reading or writing the parameter object or monitoring via EtherCAT. SDO is not synchronized to EtherCAT communication cycles, but it is sent and received in an arbitrary timing. The setting of PDO mapping is also performed using SDO.

■ SDO abort code

If an error occurs while SDO is sent and received, an abort code is sent back. The abort codes are listed in the table.

Abort code	Description
0503 0000h	Toggle bit did not inverted.
0504 0000h	SDO protocol timeout
0504 0001h	Client/server command specifier is not enabled or is unknown.
0504 0005h	Out of range of memory
0601 0000h	Unsupported access to an object
0601 0001h	Read access was performed to a write only object.
0601 0002h	Write access was performed to a read only object.
0602 0000h	The object does not exist.
0604 0041h	The object can not be mapped in PDO.
0604 0042h	The number of PDO mappings or the data length exceeded the limit.
0604 0043h	General parameter incompatibility
0604 0047h	General internal incompatibility in the device
0606 0000h	Access failed due to a hardware error
0607 0010h	Data type does not match, length of service parameter does not match.
0607 0012h	Data type does not match, length of service parameter is too long.
0607 0013h	Data type does not match, length of service parameter is too short.
0609 0011h	Sub-index does not exist.
0609 0030h	The setting range of the parameter was exceeded. (For write access)
0609 0031h	The value of the write parameter is too large.
0609 0032h	The value of the write parameter is too small.
0609 0036h	The maximum value is less than the minimum value.
0800 0000h	General error
0800 0020h	Data cannot be transferred or saved to the application.
0800 0021h	Data cannot be transferred or saved to the application because of local control.
0800 0022h	Data cannot be transferred or saved to the application in the present device status.
0800 0023h	Object dictionary cannot be generated or object dictionary does not exist.

2-6 Synchronous mode of EtherCAT

This product is compatible with three modes of EtherCAT.

● Free Run mode

The driver operates asynchronously with EtherCAT.
The communication cycle of the Free Run mode is 1 ms or more.

● Sync Manager 2 event synchronization mode

The driver operates synchronously with EtherCAT. An application is synchronized with the Sync Manager 2 event. Whenever the driver receives the process data output (RxPDO), the Sync Manager 2 event is generated.
The communication cycle of the Sync Manager 2 event synchronization mode is 1 ms or more.

● DC mode (SYNC0 event synchronization)

The driver operates synchronously with EtherCAT. An application is synchronized with the SYNC0 event.
The communication cycle of the DC mode is 0.25 ms, 0.5 ms, or 1 to 10 ms (in 1 ms increments).

2-7 Distributed Clocks

The term Distributed Clocks (DC) is a method to synchronize operation by sharing the same clock between the EtherCAT MainDevice and the driver.
 The interruption signal (SYNC0) is output at a precise interval based on the DC. In the DC mode, an application is executed synchronously with SYNC0.

2-8 Emergency message

If an error occurs in the driver, an emergency message is sent to the MainDevice using the mailbox communication. The emergency message is sent only once per error.
 The emergency message consists of the following 8 bytes.

Byte 0	Byte 1	Byte 2	Byte 3	Byte 4	Byte 5	Byte 6	Byte 7
Emergency error code		Error register object (1001h)	Manufacturer-specific error definition field				

■ Emergency message when an alarm is generated

If an alarm is generated in the driver, an emergency message is sent to the MainDevice using the mailbox communication. The emergency message when the alarm is generated consists of the following 8 bytes.

Byte 0	Byte 1	Byte 2	Byte 3	Byte 4	Byte 5	Byte 6	Byte 7
Emergency error code (FF00h)		Error register object (1001h)	Manufacturer-specific error definition field				
			0	Alarm code	0		

The emergency error code is FF00h regardless of the alarm contents.
 The byte 2 is the same value as the error register object.
 The byte 4 is the alarm code. Refer to p.198 for alarm codes.

■ Emergency code when the ESM transition error is generated

If the transition from Pre-Operational to Safe-Operational was failed in the ESM, the following emergency code is sent.

Byte 0	Byte 1	Byte 2	Byte 3	Byte 4	Byte 5	Byte 6	Byte 7
Emergency error code (A000h)		Channel (02h)	Diagnosis data				
			0Ah	0			

If the transition from Pre-Operational to Safe-Operational was requested during the following state, this emergency code is generated. Check the contents, and reconsider the setting and other conditions.

- The unsupported communication cycle in the DC mode is set.
- The object that cannot be mapped is mapped in the PDO mapping.
- The object for TxPDO is mapped in RxPDO. Or the object for RxPDO is mapped in TxPDO.

3 Drive profile

3-1 Drive state machine

The drive state machine is controlled by the Controlword object (6040h). The status of each state can be checked with the Statusword object (6041h).

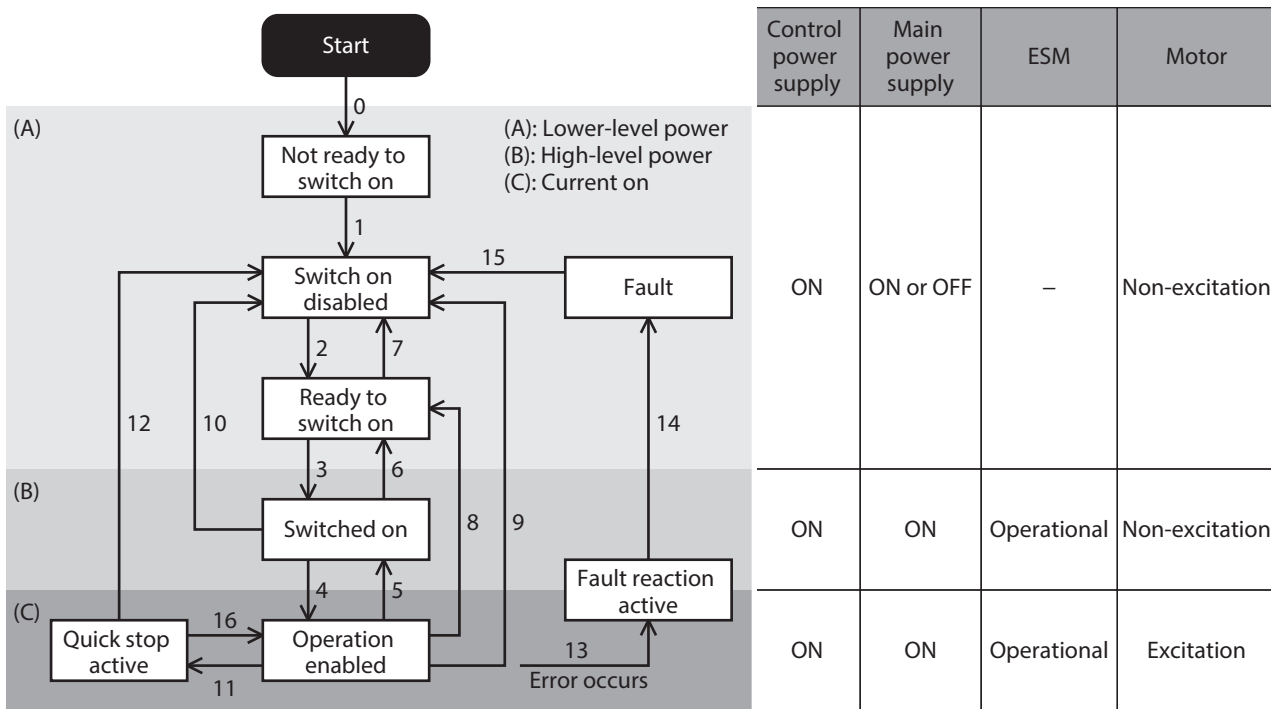

State	Signal state	Motor status	Parameter setting
Not ready to switch on	The control power supply was turned on, and the initialization processing is executing.	Non-excitation	Not possible to set
Switch on disabled	The initialization is completed.	Non-excitation	Possible to set
Ready to switch on	A state where the main power supply can be turned on.	Non-excitation	Possible to set
Switched on	A state where the main power supply was turned on.	Non-excitation	Possible to set
Operation enabled	The motor is in an excitation state, and the operation function is enabled.	Excitation	Possible to set
Quick stop active	The Quick stop command was received, and the operation stop is processing.	Excitation	Possible to set
Fault reaction active	The driver generates an alarm and the operation stop is processing.	Excitation	Possible to set
Fault	An alarm of the driver is being generated.	Non-excitation	Possible to set

Note After transitioning to "Operation enabled," 250 ms are required for the motor to be excited and for the preparation for operation to be completed. The motor does not start rotating even if the operation command is input before the preparation for operation is completed. Input the operation command after 250 ms have elapsed since the transition to "Operation enabled" or after the DCMD-RDY output is turned ON.

■ State transition of drive state machine

The drive state machine is controlled by the Controlword object (6040h).

● Controlword object (6040h)

Bit 15	Bit 14	Bit 13	Bit 12	Bit 11	Bit 10	Bit 9	Bit 8
Manufacturer specific (ms)					Reserved	oms	Halt
Bit 7	Bit 6	Bit 5	Bit 4	Bit 3	Bit 2	Bit 1	Bit 0
Fault reset	Operation mode specific (oms)			Enable operation	Quick stop	Enable voltage	Switch on

● State transition commands by Controlword

State control command	Bit 7	Bit 3	Bit 2	Bit 1	Bit 0	Transition number in the figure
Shutdown	–	–	1	1	0	2, 6, 8
Switch on	–	0	1	1	1	3*
Switch on + enable operation	–	1	1	1	1	3+4*
Disable voltage	–	–	–	0	–	7, 9, 10, 12
Quick stop	–	–	0	1	–	7, 10, 11
Disable operation	–	0	1	1	1	5
Enable operation	–	1	1	1	1	4, 16
Fault reset	0 → 1	–	–	–	–	15

* When the following conditions are not satisfied, the state will not transition from "Ready to switch on" to "Switched on" even if the command is received.

- The state of ESM is Operational.
- The main power is supplied.
- The FREE input is being OFF.
- The ETO-MON output is being OFF.
- Test operation (remote operation) is not being executed using the **MEXE02** software.

● State transition other than above

Transition number in the figure	Transition event
0	Transitions automatically when the control power supply is turned on.
1	Transitions automatically when the initialization of the driver is completed.
12	If the Quick stop option code (605Ah) is 1 to 3, transitions to "Switch on disabled" after the motor stops when the Quick stop command is send.
13, 14	Transitions if an alarm is generated

If the drive state machine is in a state of any of "Switched on," "Operation enabled," or "Quick stop active," the state transitions when an event in the table next is generated.

State	Motor operation	Event	Action
Switched on	During stop	<ul style="list-style-type: none"> • ESM transitions to other than Operational. • The main power is shut off. • The driver is in the power removal status. • The FREE input is ON. 	Transitions to "Ready to switch on." (Transition number 6)
Operation enabled	During stop	<ul style="list-style-type: none"> • ESM transitions to other than Operational. • The main power is shut off. • The driver is in the power removal status. • The FREE input is ON. 	Transitions to "Ready to switch on." (Transition number 8) The motor goes into a non-excitation state.

State	Motor operation	Event	Action	
Operation enabled	During operation	ESM transitions to other than Operational.	An alarm of Network bus error is generated (alarm code 81h). After transitioning from "Fault reaction active" to "Fault," the motor goes into a non-excitation state. (Transition number 13, 14)	
		The main power is shut off.	An alarm of Main power supply off is generated (alarm code 23h). After transitioning from "Fault reaction active" to "Fault," the motor goes into a non-excitation state. (Transition number 13, 14)	
		<ul style="list-style-type: none"> The driver is in the power removal status. The FREE input is ON. 	Transitions to "Ready to switch on." (Transition number 8) The motor goes into a non-excitation state.	
Quick stop active	During stop	<ul style="list-style-type: none"> ESM transitions to other than Operational. The main power is shut off. The driver is in the power removal status. The FREE input is ON. 	Transitions to "Switch on disabled." (Transition number 12) The motor goes into a non-excitation state.	
		During operation	ESM transitions to other than Operational.	An alarm of Network bus error is generated (alarm code 81h). After transitioning from "Fault reaction active" to "Fault," the motor goes into a non-excitation state. (Transition number 13, 14)
			The main power is shut off.	An alarm of Main power supply off is generated (alarm code 23h). After transitioning from "Fault reaction active" to "Fault," the motor goes into a non-excitation state. (Transition number 13, 14)
	During operation	<ul style="list-style-type: none"> The driver is in the power removal status. The FREE input is ON. 	Transitions to "Switch on disabled." (Transition number 12) The motor goes into a non-excitation state.	

■ Status output of drive state machine

The status of the drive state machine is output by the Statusword object (6041h).

● Statusword object (6041h)

Bit 15	Bit 14	Bit 13	Bit 12	Bit 11	Bit 10	Bit 9	Bit 8
Manufacturer specific (ms)		Operation mode specific (oms)		Internal limit active	Target reached	Remote	ms
Bit 7	Bit 6	Bit 5	Bit 4	Bit 3	Bit 2	Bit 1	Bit 0
Warning	Switch on disabled	Quick stop	Voltage enabled	Fault	Operation enabled	Switched on	Ready to switch on

● Status output of Statusword

State	Bit 6	Bit 5	Bit 4	Bit 3	Bit 2	Bit 1	Bit 0
Start	0	0	0	0	0	0	0
Not ready to switch on	0	0	0	0	0	0	0
Fault	0	1	—*	1	0	0	0
Fault reaction active	0	1	—*	1	1	1	1
Switch on disabled	1	1	—*	0	0	0	0
Ready to switch on	0	1	—*	0	0	0	1
Switched on	0	1	—*	0	0	1	1
Operation enabled	0	1	—*	0	1	1	1
Quick stop active	0	0	—*	0	1	1	1

* "Voltage enabled" changes to 1 while the main power is supplied.

3-2 Operation modes

The driver supports the operation modes listed below.

- Cyclic synchronous position mode (CSP)
- Profile position mode (PP)
- Cyclic synchronous velocity mode (CSV)
- Profile velocity mode (PV)
- Homing mode (HM)

■ Switching of operation mode

The operation mode can be switched by the Modes of operation (6060h).

Setting value of operation mode	Operation mode
0 (Initial value)	Operation function disable
1	Profile position mode (PP)
3	Profile velocity mode (PV)
6	Homing mode (HM)
8	Cyclic synchronous position mode (CSP)
9	Cyclic synchronous velocity mode (CSV)

Switch the operation mode while operation is stopped. When it was switched during operation, the new operation mode will be enabled after the operation is stopped.

The operation mode that is enabled can be checked in the Modes of operation display (6061h).

3-3 Cyclic synchronous position mode (CSP)

In the Cyclic synchronous position mode, path generation (profile generation) is performed by the EtherCAT MainDevice. By cyclic synchronous communication, when the Target position (607Ah) is sent from the MainDevice to the driver, the driver performs position control.

Use the Cyclic synchronous position mode when EtherCAT is operating in the DC mode. If the Cyclic synchronous position mode is used in the Free Run mode or Sync Manager 2 event synchronization mode, the speed fluctuation or vibration may increase.

Note

- Since the position is managed by the MainDevice in the Cyclic synchronous position mode, if the operation is stopped without the MainDevice, the position deviation may cause. When inputting the stop signal, such as the STOP input or the FREE input, or when executing the power removal function, be sure to perform the following actions to clear the position deviation. If the stop signal is turned OFF while the position deviation is remained or if the ETO-CLR input is turned ON after the power removal status is released, the motor may start running suddenly.
 - Execute the operation stop from the MainDevice.
 - Clear the position deviation between the MainDevice and the driver.
- Since the position is managed by the MainDevice in the Cyclic synchronous position mode, executing the position preset (P-PRESET) in the driver while the motor is excited may cause the motor to start suddenly or an alarm of Command position error to generate. Put the motor in a non-excitation state before executing the position preset (P-PRESET) in the driver.

Related objects

Index	Sub	Name	Type	Access	PDO	Save	Range	Update
6040h	00h	Controlword	U16	RW	RxPDO	–	0000h to FFFFh (Initial value: 0000h)	A
6041h	00h	Statusword	U16	RO	TxPDO	–	–	–
6060h	00h	Modes of operation	INT8	RW	RxPDO	○	0 (Initial value), 1, 3, 6, 8, 9 (⇔ “Switching of operation mode”)	B
6061h	00h	Modes of operation display	INT8	RO	TxPDO	–	–	–
6062h	00h	Position demand value [step]	INT32	RO	TxPDO	–	–	–

Index	Sub	Name	Type	Access	PDO	Save	Range	Update
6064h	00h	Position actual value [step]	INT32	RO	TxPDO	–	–	–
6072h	00h	Max torque [1=0.1 %]	U16	RW	RxPDO	○	1 to 10,000 (Initial value: 1,000)	A
607Ah	00h	Target position [step]	INT32	RW	RxPDO	–	–2,147,483,648 to 2,147,483,647 (Initial value: 0)	A
607Dh	01h	Min. position limit [step]	INT32	RW	No	○	–2,147,483,648 to 2,147,483,647 (Initial value: –2,147,483,648)	A
	02h	Max. position limit [step]	INT32	RW	No	○	–2,147,483,648 to 2,147,483,647 (Initial value: 2,147,483,647)	A

■ Controlword of Cyclic synchronous position mode

Bit 15	Bit 14	Bit 13	Bit 12	Bit 11	Bit 10	Bit 9	Bit 8
Manufacturer specific (ms)					Reserved	oms	Halt
–	–	–	–	–		–	
Bit 7	Bit 6	Bit 5	Bit 4	Bit 3	Bit 2	Bit 1	Bit 0
Fault reset	Operation mode specific (oms)			Enable operation	Quick stop	Enable voltage	Switch on
	–	–	–				

Details of Controlword

Bit	Name	Value	Description
8	Halt	0	Operation is allowed.
		1	Stop operation. The stopping method is "Immediate stop."

For bit 7 and bit 3 to bit 0, refer to "State transition of drive state machine" on p.72.

■ Statusword of Cyclic synchronous position mode

Bit 15	Bit 14	Bit 13	Bit 12	Bit 11	Bit 10	Bit 9	Bit 8
Manufacturer specific		Operation mode specific		Internal limit active	–	Remote	ms
TLC	–	Following error	Target position ignored				–
Bit 7	Bit 6	Bit 5	Bit 4	Bit 3	Bit 2	Bit 1	Bit 0
Warning	Switch on disabled	Quick stop	Voltage enabled	Fault	Operation enabled	Switched on	Ready to switch on

Details of Statusword

Bit	Name	Value	Description
15	TLC	0	A load does not reach the upper limit of the motor output torque.
		1	A load reached the upper limit of the motor output torque.
13	Following error	0	The position deviation error does not occur.
		1	The position deviation error occurs. The position deviation exceeded the value set in the Following error window (6065h). The value changes to 0 if an alarm of Excessive position deviation (alarm code 10h) or an alarm of Overload (alarm code 30h) is reset.

Bit	Name	Value	Description
12	Target position ignored	0	The target position command is disabled. When the state is any of the following, the value changes to 0 and the target position is disabled. <ul style="list-style-type: none"> • The drive state machine is other than "Operation enabled." • The motor is in a non-excitation state. • The Halt (6040h: bit 8) has been set to 1. • The STOP input is being ON. • The internal limit is in an active state.
		1	The target position command is enabled.
11	Internal limit active	0	The function limitation by the internal limit is not in an active state.
		1	The function limitation by the internal limit became an active state. The value changes to 1 while any of the internal limit functions listed below are activated. <ul style="list-style-type: none"> • Limit sensor (FW-LS/RV-LS) • Operation prohibition input (FW-BLK/RV-BLK) • Software limit • Mechanism limit
9	Remote	1	The value changes to 1 when the initialization is completed.
7	Warning	0	Information is not generated. When the cause of information is cleared, the Warning is automatically cleared to 0.
		1	Information is being generated.

For bit 6 to bit 0, refer to "Status output of drive state machine" on p.73.

3-4 Profile position mode (PP)

The Profile position mode operates in the internal profile of the driver. Path generation (profile generation) is performed with the driver. The target position, velocity, acceleration and others are set with the EtherCAT MainDevice.

Related objects

Index	Sub	Name	Type	Access	PDO	Save	Range	Update
6040h	00h	Controlword	U16	RW	RxPDO	–	0000h to FFFFh (Initial value: 0000h)	A
6041h	00h	Statusword	U16	RO	TxPDO	–	–	–
6060h	00h	Modes of operation	INT8	RW	RxPDO	○	0 (Initial value), 1, 3, 6, 8, 9 (⇨ p.74)	B
6061h	00h	Modes of operation display	INT8	RO	TxPDO	–	–	–
6062h	00h	Position demand value [step]	INT32	RO	TxPDO	–	–	–
6064h	00h	Position actual value [step]	INT32	RO	TxPDO	–	–	–
6072h	00h	Max torque [1=0.1 %]	U16	RW	RxPDO	○	1 to 10,000 (Initial value: 1,000)	A
607Ah	00h	Target position [step]	INT32	RW	RxPDO	–	–2,147,483,648 to 2,147,483,647 (Initial value: 0)	A
607Dh	01h	Min. position limit [step]	INT32	RW	No	○	–2,147,483,648 to 2,147,483,647 (Initial value: –2,147,483,648)	A
	02h	Max. position limit [step]	INT32	RW	No	○	–2,147,483,648 to 2,147,483,647 (Initial value: 2,147,483,647)	A
6081h	00h	Profile velocity [Hz]	U32	RW	RxPDO	○	0 to 4,000,000 (Initial value: 10,000)	B
6083h	00h	Profile acceleration [step/s ²]	U32	RW	RxPDO	○	1 to 1,000,000,000 (Initial value: 300,000)	B

Index	Sub	Name	Type	Access	PDO	Save	Range	Update
6084h	00h	Profile deceleration [step/s ²]	U32	RW	RxPDO	○	1 to 1,000,000,000 (Initial value: 300,000)	B
4142h	00h	Starting speed [Hz]	INT32	RW	No	○	0 to 4,000,000 (Initial value: 5,000)	B
414Fh	00h	Wrap positioning mode	U8	RW	RxPDO	○	0: Wrap absolute positioning 1: Wrap proximity 2: Wrap forward direction 3: Wrap reverse direction (Initial value: 0)	B

■ Controlword of Profile position mode

Bit 15	Bit 14	Bit 13	Bit 12	Bit 11	Bit 10	Bit 9	Bit 8
Manufacturer specific (ms)					Reserved	oms	Halt
–	Wrap	–	Base position of Rel	–		Change on set point	
Bit 7	Bit 6	Bit 5	Bit 4	Bit 3	Bit 2	Bit 1	Bit 0
Fault reset	Operation mode specific (oms)			Enable operation	Quick stop	Enable voltage	Switch on
	Abs/Rel	Change set immediately	New set point				

Details of Controlword

Bit	Name	Value	Description
14	Wrap	1	Wrap absolute positioning operation After the Wrap is set to 1, when the New set point (6040h: bit 4) is set to 1 to start operation, wrap absolute positioning operation is performed. The operating method is in accordance with the setting of the Wrap positioning mode (414Fh).
12	Base position of Rel	0	Incremental positioning operation (based on command position) Positioning operation of the set travel amount is performed from the present command position. The travel amount is set with the Target position (607Ah).
		1	Incremental positioning operation (based on feedback position) Positioning operation of the set travel amount is performed from the present feedback position. The travel amount is set with the Target position (607Ah).
10	Reserved	–	Reserved
9	Change on set point	–	Not supported.
8	Halt	0	Operation is allowed.
		1	Stop operation. The stopping method is based on the setting of the Halt option code (605Dh).
6	Abs/Rel	0	Absolute positioning operation The Target position (607Ah) is applied to the target position of absolute positioning operation.
		1	Incremental positioning operation The Target position (607Ah) is applied to the target position of incremental positioning operation.
5	Change set immediately	0	When the New set point (6040h: bit 4) is set from 0 to 1 during operation, the new operation command is saved. When the present operation is completed, the stored new operation command is started.
		1	When the New set point (6040h: bit 4) is set from 0 to 1 during operation, the new operation command is immediately applied.

Bit	Name	Value	Description
4	New set point	0 → 1	<p>Start of positioning operation Before starting operation, select the Wrap (6040h: bit 14), Push (6040h: bit 13), Base position of Rel (6040h: bit 12), and Abs/Rel (6040h: bit 6).</p> <p>When positioning operation is started in a state where the operation is stopped by setting the Halt (6040h: bit 8) to 1, set the Halt (6040h: bit 8) from 1 to 0 first and leave an interval at more than double of the communication cycle before setting the New set point (6040h: bit 4) from 0 to 1. The operation may not be started unless an interval of more than twice the communication cycle has elapsed.</p> <p>The command cannot be received in the following state, and the operation is not started.</p> <ul style="list-style-type: none"> • The Halt (6040h: bit 8) has been set to 1. • The STOP input is being ON. • The drive state machine is other than "Operation enabled." • The motor is in a non-excitation state.

For bit 7 and bit 3 to bit 0, refer to "State transition of drive state machine" on p.72.

■ Statusword of Profile position mode

Bit 15	Bit 14	Bit 13	Bit 12	Bit 11	Bit 10	Bit 9	Bit 8
Manufacturer specific		Operation mode specific		Internal limit active	Target reached	Remote	ms
TLC	–	Following error	Set point acknowledge				–
Bit 7	Bit 6	Bit 5	Bit 4	Bit 3	Bit 2	Bit 1	Bit 0
Warning	Switch on disabled	Quick stop	Voltage enabled	Fault	Operation enabled	Switched on	Ready to switch on

Details of Statusword

Bit	Name	Value	Description
15	TLC	0	A load does not reach the upper limit of the motor output torque.
		1	A load reached the upper limit of the motor output torque.
13	Following error	0	The position deviation error does not occur.
		1	The position deviation error occurs. The position deviation exceeded the value set in the Following error window (6065h). The value changes to 0 if an alarm of Excessive position deviation (alarm code 10h) or an alarm of Overload (alarm code 30h) is reset.
12	Set point acknowledge	0	The operation start by the New set point (6040h: bit 4) has not been received.
		1	The operation start by the New set point (6040h: bit 4) was received. When the New set point (6040h: bit 4) is set to 1 to receive the operation start, the Set point acknowledge changes to 1. When the New set point (6040h: bit 4) is set to 0, the Set point acknowledge also changes to 0.
11	Internal limit active	0	The function limitation by the internal limit is not in an active state.
		1	The function limitation by the internal limit became an active state. The value changes to 1 while any of the internal limit functions listed below are activated. <ul style="list-style-type: none"> • Limit sensor (FW-LS/RV-LS) • Operation prohibition input (FW-BLK/RV-BLK) • Software limit • Mechanism limit
10	Target reached	0	<ul style="list-style-type: none"> • When the Halt (6040h: bit 8) is 0: Positioning operation is not completed. • When the Halt (6040h: bit 8) is 1: During deceleration stop.
		1	<ul style="list-style-type: none"> • When the Halt (6040h: bit 8) is 0: After positioning operation is properly completed, the value changes to 1 when the feedback position has converged in a range of the Position window (6067h) with respect to the command position. It does not change to 1 when the positioning operation was interrupted along the way. It changes to 0 if operation is started from a state where the positioning was completed. • When the Halt (6040h: bit 8) is 1: The value changes to 1 when the operation command speed becomes 0.
9	Remote	1	The value changes to 1 when the initialization is completed.
7	Warning	0	Information is not generated. When the cause of information is cleared, the Warning is automatically cleared to 0.
		1	Information is being generated.

For bit 6 to bit 0, refer to "Status output of drive state machine" on p.73.

■ Operation in Profile position mode

● Positioning operation

Positioning operation is started when the Target position (607Ah) is set and the New set point (6040h: bit 4) is set to 1.

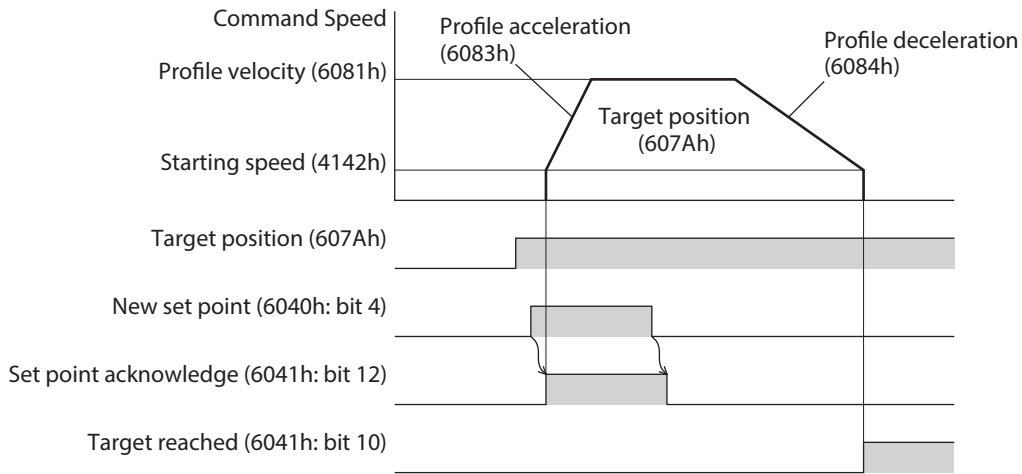

Single set-point [When the Change set immediately (6040h: bit 5) is 1]

If the New set point (6040h: bit 4) is newly set during operation, the new operation command is applied immediately.

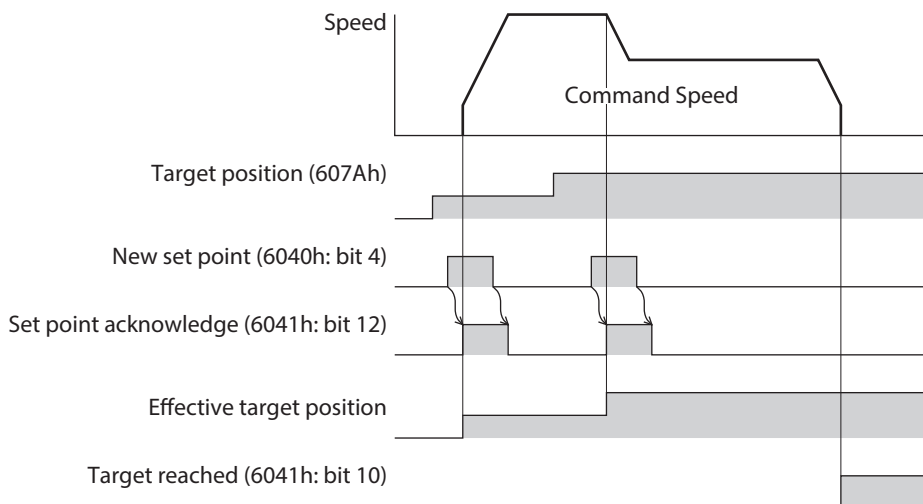

Set of set-points [When the Change set immediately (6040h: bit 5) is 0]

When the New set point (6040h: bit 4) is newly set during operation, the new operation command is saved. When the present operation is completed, the stored new operation command is started.

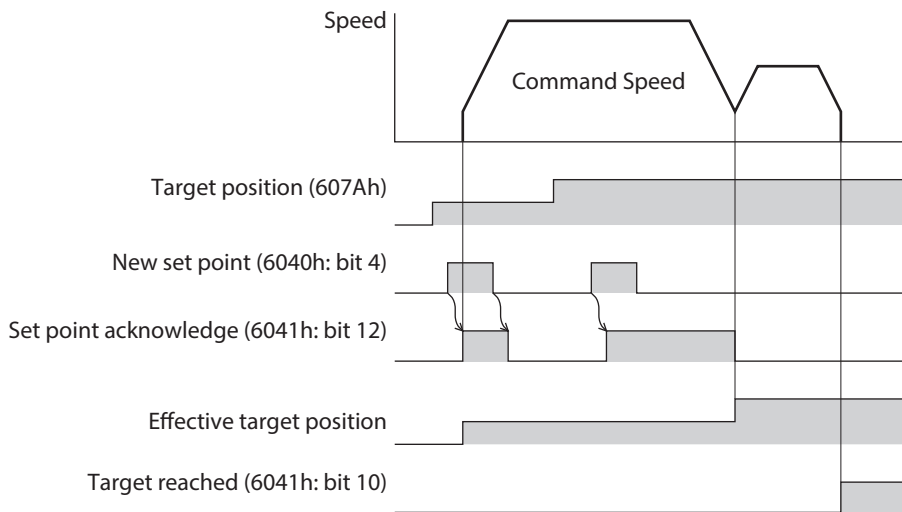

● **Wrap absolute positioning operation**

After the Target position (607Ah) is set and the Wrap (6040h: bit 14) is set to 1, wrap absolute positioning operation is started when the New set point (6040h: bit 4) is set to 1. With wrap absolute positioning operation, absolute positioning operation is performed regardless of the value of the Abs/Rel (6040h: bit 6).

memo When wrap absolute positioning operation is performed, set the Wrap (RND) setting (41C7h) to "1: Enable."

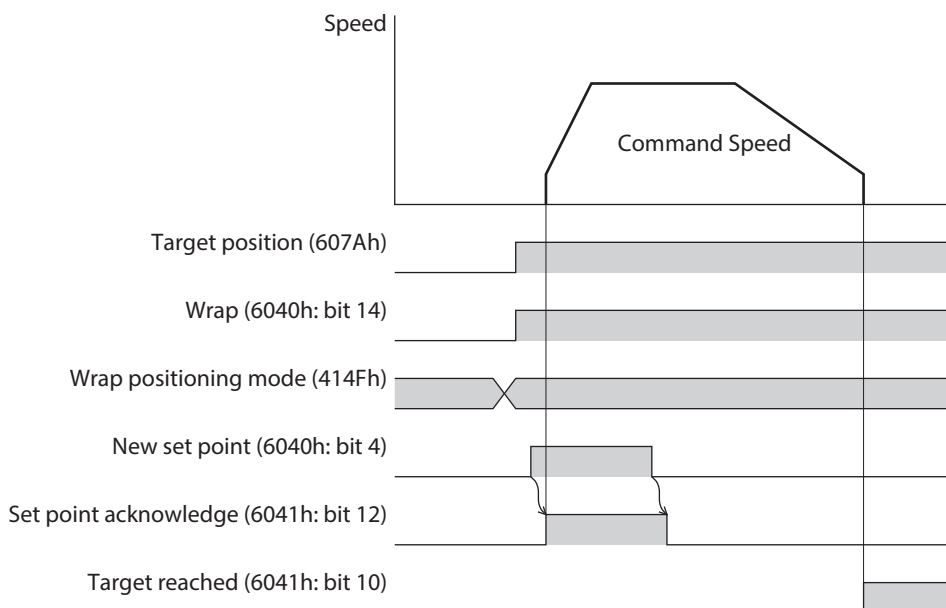

■ Operation type of Profile position mode

The operation type of the Profile position mode is set with the Controlword (6040h) and the Wrap positioning mode (414Fh). The operation modes are listed in the table.

Operation type	Wrap positioning mode (414Fh)	Controlword (6040h)			
		Wrap (Bit 14)	Push (Bit 13)	Base position of Rel (Bit 12)	Abs/Rel (Bit 6)
Absolute positioning	–	0	0	–	0
Incremental positioning (Based on command position)	–	0	0	0	1
Incremental positioning (Based on feedback position)	–	0	0	1	1
Wrap absolute positioning	0	1	0	–	–
Wrap proximity positioning	1	1	0	–	–
Wrap forward direction absolute positioning	2	1	0	–	–
Wrap reverse direction absolute positioning	3	1	0	–	–

● Absolute positioning

Positioning operation is performed from the present position to the set target position. In the Target position (607Ah), set the target position on the coordinates with the home as a reference.

Example: When moving from the command position "1,000" to the target position "4,000"

Set 4,000 steps in the Target position (607Ah) to start absolute positioning operation.

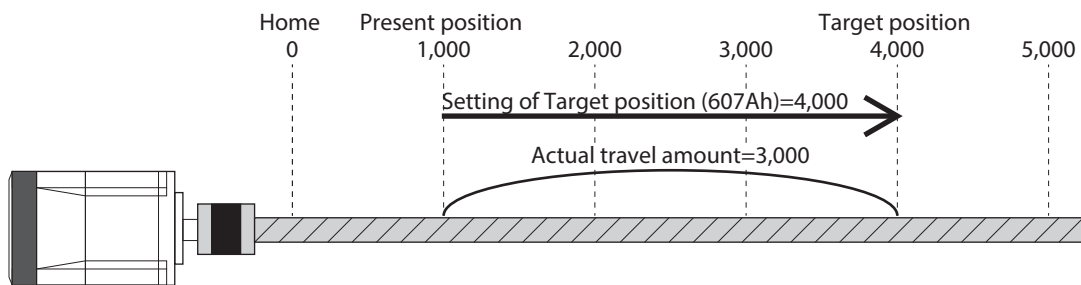

● Incremental positioning (based on command position)

Positioning operation with the set travel amount is performed from the present command position. In the Target position (607Ah), set the travel amount from the present command position to the target position.

Example: When moving from the command position "1,000" to the target position "4,000"

Set 3,000 steps in the Target position (607Ah) to start incremental positioning (based on command position) operation.

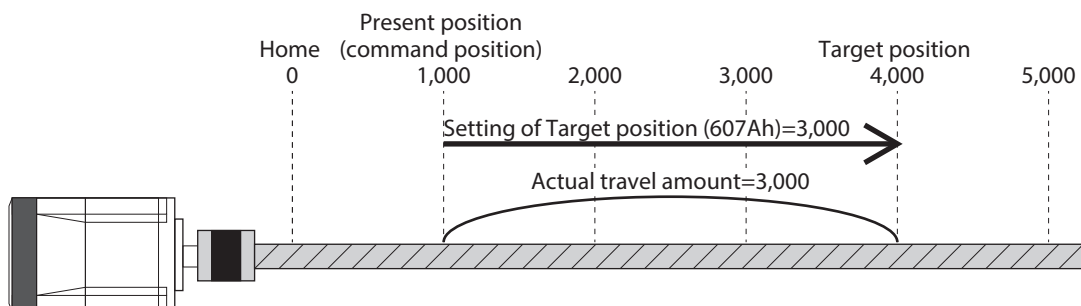

● **Incremental positioning (Based on feedback position)**

Positioning operation with the set travel amount is performed from the present feedback position. In the Target position (607Ah), set the travel amount from the present feedback position.

Example: When moving 3,000 steps from the command position "1,000" and the feedback position "900"

Set 3,000 steps in the Target position (607Ah) to start incremental positioning (based on feedback position) operation. The command position and the feedback position after the operation is completed will be "3,900."

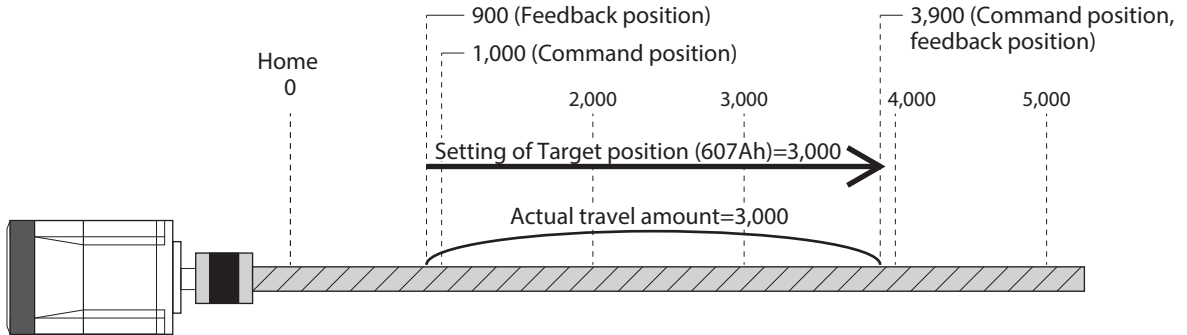

memo The reference position of the operation based on the feedback position varies depending on a load.

● **Wrap absolute positioning**

Positioning operation is performed to the target position within the wrap range. In the Target position (607Ah), set the target position within the wrap range. Refer to p.108 for the wrap function.

Example: When moving from the command position "1,000" to the target position "4,000" (wrap setting range: 1.0 rev, wrap offset ratio: 50.00 %)

Set the items in the table to start wrap absolute positioning operation.

Index	Name	Setting value
41C7h	Wrap (RND) setting	1: Enable
41C9h	Initial coordinate generation & wrap setting range [1=0.1 rev]	10
41CBh	Initial coordinate generation & wrap range offset ratio [1=0.01 %]	5,000
414Fh	Wrap positioning mode	0: Wrap absolute positioning
607Ah	Target position [step]	4,000

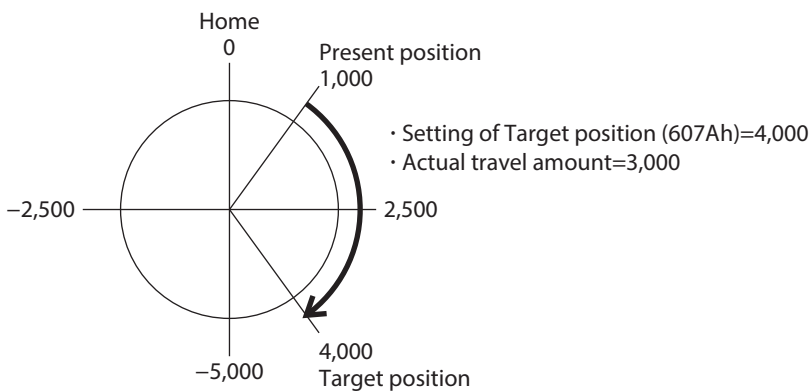

● **Wrap proximity positioning**

Positioning operation in the shortest distance is performed to the target position within the wrap range. In the Target position (607Ah), set the target position within the wrap range. Refer to p.108 for the wrap function.

Example: When moving from the command position "-4,000" to the target position "4,000" (wrap setting range: 1.0 rev, wrap offset ratio: 50.00 %)

Set the items in the table to start wrap proximity positioning operation.

Index	Name	Setting value
41C7h	Wrap (RND) setting	1: Enable
41C9h	Initial coordinate generation & wrap setting range [1=0.1 rev]	10
41CBh	Initial coordinate generation & wrap range offset ratio [1=0.01 %]	5,000
414Fh	Wrap positioning mode	1: Wrap proximity
607Ah	Target position [step]	4,000

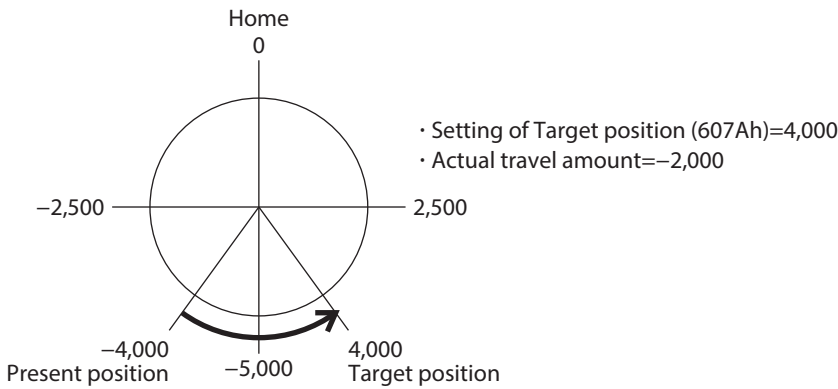

● **Wrap forward direction absolute positioning**

Positioning operation in the forward direction is performed to the target position within the wrap range. In the Target position (607Ah), set the target position within the wrap range. Refer to p.108 for the wrap function.

Example: When moving from the command position "1,000" to the target position "-4,000" (wrap setting range: 1.0 rev, wrap offset ratio: 50.00 %)

Set the items in the table to start wrap forward direction absolute positioning operation.

Index	Name	Setting value
41C7h	Wrap (RND) setting	1: Enable
41C9h	Initial coordinate generation & wrap setting range [1=0.1 rev]	10
41CBh	Initial coordinate generation & wrap range offset ratio [1=0.01 %]	5,000
414Fh	Wrap positioning mode	2: Wrap forward direction
607Ah	Target position [step]	-4,000

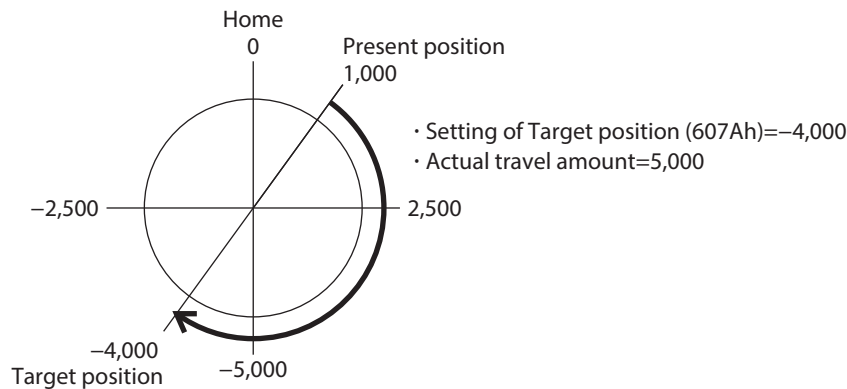

● Wrap reverse direction absolute positioning

Positioning operation in the reverse direction is performed to the target position within the wrap range. In the Target position (607Ah), set the target position within the wrap range. Refer to p.108 for the wrap function.

Example: When moving from the command position "1,000" to the target position "4,000" (wrap setting range: 1.0 rev, wrap offset ratio: 50.00 %)

Set the items in the table to start wrap reverse direction absolute positioning operation.

Index	Name	Setting value
41C7h	Wrap (RND) setting	1: Enable
41C9h	Initial coordinate generation & wrap setting range [1=0.1 rev]	10
41CBh	Initial coordinate generation & wrap range offset ratio [1=0.01 %]	5,000
414Fh	Wrap positioning mode	3: Wrap reverse direction
607Ah	Target position [step]	4,000

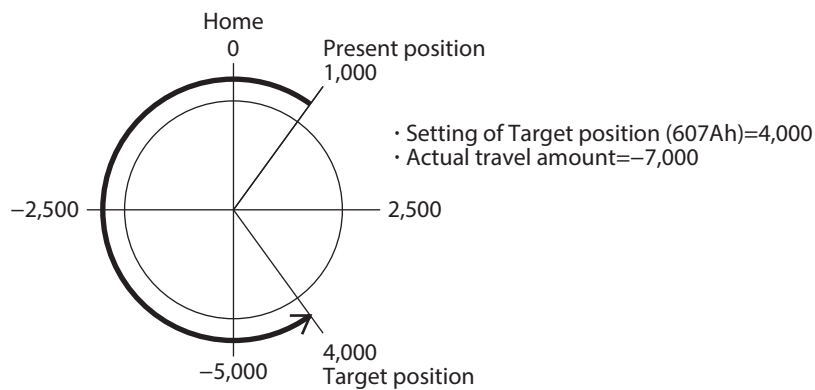

■ Orbit comparison of positioning operation

These are examples when the wrap setting range is set to 1 rev and the wrap range offset ratio is set to 50 %.

Operation type	From an initial value to a value set in the target position (607Ah)	
	2,500 → 9,000	2,500 → -14,000
<ul style="list-style-type: none"> • Absolute positioning <p>* Sets coordinates of the target position from the home.</p>		
<ul style="list-style-type: none"> • Incremental positioning (Based on command position) • Incremental positioning (Based on feedback position) <p>* Sets the travel amount from the command position or the feedback position to the target position.</p>		
<ul style="list-style-type: none"> • Wrap absolute positioning <p>* Sets the target position on coordinates with the home as a reference and operates within the wrap range.</p>		
<ul style="list-style-type: none"> • Wrap proximity positioning <p>* Sets the target position on coordinates with the home as a reference and operates toward the target position within the wrap range in the shortest distance.</p>		
<ul style="list-style-type: none"> • Wrap forward direction absolute positioning <p>* Sets the target position on coordinates with the home as a reference and operates in the forward direction (FWD) toward the target position within the wrap range.</p>		
<ul style="list-style-type: none"> • Wrap reverse direction absolute positioning <p>* Sets the target position on coordinates with the home as a reference and operates in the reverse direction (RVS) toward the target position within the wrap range.</p>		

* The value in □ represents the coordinates of the position where the motor stopped.

3-5 Cyclic synchronous velocity mode (CSV)

In the Cyclic synchronous velocity mode, path generation (profile generation) is performed by the EtherCAT MainDevice. By cyclic synchronous communication, when the Target velocity (60FFh) is sent from the MainDevice to the driver, the driver performs speed control.

Related objects

Index	Sub	Name	Type	Access	PDO	Save	Range	Update
6040h	00h	Controlword	U16	RW	RxPDO	–	0000h to FFFFh (Initial value: 0000h)	A
6041h	00h	Statusword	U16	RO	TxPDO	–	–	–
6060h	00h	Modes of operation	INT8	RW	RxPDO	○	0 (Initial value), 1, 3, 6, 8, 9(⇒ p.74)	B
6061h	00h	Modes of operation display	INT8	RO	TxPDO	–	–	–
606Bh	00h	Velocity demand value [Hz]	INT32	RO	TxPDO	–	–	–
606Ch	00h	Velocity actual value [Hz]	INT32	RO	TxPDO	–	–	–
6072h	00h	Max torque [1=0.1 %]	U16	RW	RxPDO	○	1 to 10,000 (Initial value: 1,000)	A
60FFh	00h	Target velocity [Hz]	INT32	RW	RxPDO	–	-4,000,000 to 4,000,000 (Initial value: 0)	A

■ Controlword of Cyclic synchronous velocity mode

Bit 15	Bit 14	Bit 13	Bit 12	Bit 11	Bit 10	Bit 9	Bit 8
Manufacturer specific (ms)					Reserved	oms	Halt
–	–	–	–	–		–	
Bit 7	Bit 6	Bit 5	Bit 4	Bit 3	Bit 2	Bit 1	Bit 0
Fault reset	Operation mode specific (oms)			Enable operation	Quick stop	Enable voltage	Switch on
	–	–	–				

Details of Controlword

Bit	Name	Value	Description
8	Halt	0	Operation is allowed.
		1	Stop operation. The stopping method is "Immediate stop."

For bit 7 and bit 3 to bit 0, refer to "State transition of drive state machine" on p.72.

■ Statusword of Cyclic synchronous velocity mode

Bit 15	Bit 14	Bit 13	Bit 12	Bit 11	Bit 10	Bit 9	Bit 8
Manufacturer specific		Operation mode specific		Internal limit active	Reserved	Remote	ms
TLC	–	Reserved	Target velocity ignored				–
Bit 7	Bit 6	Bit 5	Bit 4	Bit 3	Bit 2	Bit 1	Bit 0
Warning	Switch on disabled	Quick stop	Voltage enabled	Fault	Operation enabled	Switched on	Ready to switch on

Details of Statusword

Bit	Name	Value	Description
15	TLC	0	A load does not reach the upper limit of the motor output torque.
		1	A load reached the upper limit of the motor output torque.
13	Reserved	0	Reserved
12	Target velocity ignored	0	The target velocity command is disabled. When the state is any of the following, the value changes to 0 and the Target velocity is disabled. <ul style="list-style-type: none"> • The drive state machine is other than "Operation enabled." • The motor is in a non-excitation state. • The Halt (6040h: bit 8) has been set to 1. • The STOP input is being ON. • The internal limit is in an active state.
		1	The target velocity command is enabled.
11	Internal limit active	0	The function limitation by the internal limit is not in an active state.
		1	The function limitation by the internal limit became an active state. The value changes to 1 while any of the internal limit functions listed below are activated. <ul style="list-style-type: none"> • Limit sensor (FW-LS/RV-LS) • Operation prohibition input (FW-BLK/RV-BLK) • Software limit • Mechanism limit
10	Reserved	0	Reserved
9	Remote	1	The value changes to 1 when the initialization is completed.
7	Warning	0	Information is not generated. When the cause of information is cleared, the Warning is automatically cleared to 0.
		1	Information is being generated.

For bit 6 to bit 0, refer to "Status output of drive state machine" on p.73.

■ Operation in Cyclic synchronous velocity mode

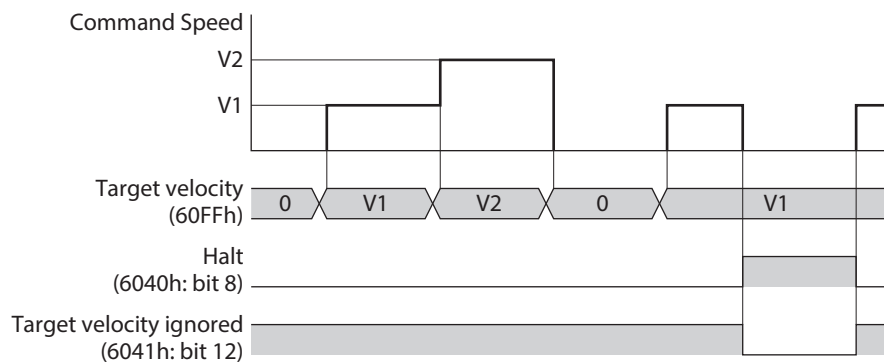

3-6 Profile velocity mode (PV)

The Profile velocity mode operates in the internal profile of the driver. Path generation (profile generation) is performed with the driver. The velocity, acceleration, and others are set with the EtherCAT MainDevice.

Related objects

Index	Sub	Name	Type	Access	PDO	Save	Range	Update
6040h	00h	Controlword	U16	RW	RxPDO	–	0000h to FFFFh (Initial value: 0000h)	A
6041h	00h	Statusword	U16	RO	TxPDO	–	–	–
6060h	00h	Modes of operation	INT8	RW	RxPDO	○	0 (Initial value), 1, 3, 6, 8, 9 (⇒ p.74)	B
6061h	00h	Modes of operation display	INT8	RO	TxPDO	–	–	–
606Bh	00h	Velocity demand value [Hz]	INT32	RO	TxPDO	–	–	–
606Ch	00h	Velocity actual value [Hz]	INT32	RO	TxPDO	–	–	–
6072h	00h	Max torque [1=0.1 %]	U16	RW	RxPDO	○	0 to 10,000 (Initial value: 1,000)	A
6083h	00h	Profile acceleration [step/s ²]	U32	RW	RxPDO	○	1 to 1,000,000,000 (Initial value: 300,000)	B
6084h	00h	Profile deceleration [step/s ²]	U32	RW	RxPDO	○	1 to 1,000,000,000 (Initial value: 300,000)	B
60FFh	00h	Target velocity [Hz]	INT32	RW	RxPDO	–	–4,000,000 to 4,000,000 (Initial value: 0)	B
4142h	00h	Starting speed [Hz]	INT32	RW	No	○	0 to 4,000,000 (Initial value: 5,000)	B

■ Controlword of Profile velocity mode

Bit 15	Bit 14	Bit 13	Bit 12	Bit 11	Bit 10	Bit 9	Bit 8
Manufacturer specific (ms)					Reserved	oms	Halt
–	–	–	–	–		–	
Bit 7	Bit 6	Bit 5	Bit 4	Bit 3	Bit 2	Bit 1	Bit 0
Fault reset	Operation mode specific (oms)			Enable operation	Quick stop	Enable voltage	Switch on
	–	–	–				

Details of Controlword

Bit	Name	Value	Description
8	Halt	0	Operation is allowed.
		1	Stop operation. The stopping method is based on the setting of the Halt option code (605Dh).

For bit 7 and bit 3 to bit 0, refer to “State transition of drive state machine” on p.72.

■ Statusword of Profile velocity mode

Bit 15	Bit 14	Bit 13	Bit 12	Bit 11	Bit 10	Bit 9	Bit 8
Manufacturer specific		Operation mode specific		Internal limit active	Target reached	Remote	ms
TLC	–	–	Speed				–
Bit 7	Bit 6	Bit 5	Bit 4	Bit 3	Bit 2	Bit 1	Bit 0
Warning	Switch on disabled	Quick stop	Voltage enabled	Fault	Operation enabled	Switched on	Ready to switch on

Details of Statusword

Bit	Name	Value	Description
15	TLC	0	A load does not reach the upper limit of the motor output torque.
		1	A load reached the upper limit of the motor output torque.
12	Speed	0	Internal command speed is other than 0.
		1	Internal command speed is 0.
11	Internal limit active	0	The function limitation by the internal limit is not in an active state.
		1	The function limitation by the internal limit became an active state. The value changes to 1 while any of the internal limit functions listed below are activated. <ul style="list-style-type: none"> • Limit sensor (FW-LS/RV-LS) • Operation prohibition input (FW-BLK/RV-BLK) • Software limit • Mechanism limit
10	Target reached	0	<ul style="list-style-type: none"> • When the Halt (6040h: bit 8) is 0: The internal feedback speed does not reach the Target velocity (60FFh). • When the Halt (6040h: bit 8) is 1: During deceleration stop. (Internal command speed is other than 0.)
		1	<ul style="list-style-type: none"> • When the Halt (6040h: bit 8) is 0: The internal feedback speed reached the Target velocity (60FFh). When the Halt is 0, the status of the VA output signal is output. The judgment criterion of the target velocity reached can be set with the VA mode selection (4718h) and the VA detection speed range (4719h). • When the Halt (6040h: bit 8) is 1: The internal command speed is 0.
9	Remote	1	The value changes to 1 when the initialization is completed.
7	Warning	0	Information is not generated. When the cause of information is cleared, the Warning is automatically cleared to 0.
		1	Information is being generated.

For bit 6 to bit 0, refer to "Status output of drive state machine" on p.73.

■ Operation in Profile velocity mode

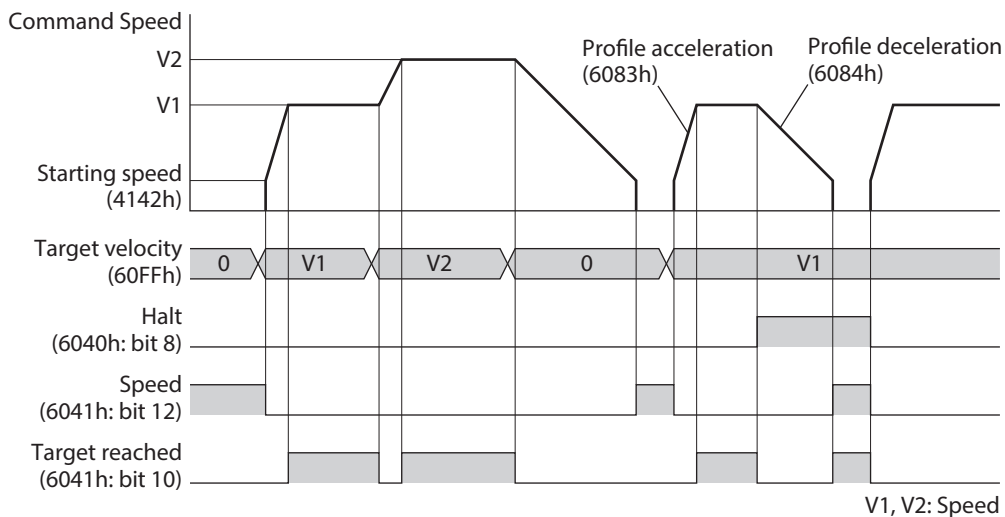

3-7 Homing mode (HM)

The Homing mode is used to set the home. Path generation (profile generation) is performed with the driver. If return-to-home operation is performed, the position preset (P-PRESET) is executed when the operation is completed, and the home will be the value set in the Home offset (607Ch).

● Related objects

Refer to "Selection of return-to-home (Homing) method" on p.93.

■ Before starting operation; When a motorized actuator is used

For parameters of the **AZX** Series, the different values have been stored in the ABZO sensor and the driver, respectively. The values based on the product specifications are stored in the ABZO sensor. The values stored in the ABZO sensor cannot be changed because of the fixed value. Meantime, the values for the standard type (motor only) are stored in the driver parameters.

In a state of the factory shipment, the parameter information (fixed value) stored in the ABZO sensor is used preferentially. Since parameters stored in the driver are prioritized in the Homing mode, change the setting according to the following steps.

1. Copy the ABZO information (fixed value) of the ABZO sensor to the driver. Refer to p.15 for details.
2. Change the JOG/HOME/ZHOME operation setting (47F5h) to "1: Manual setting."
3. Change the Homing method (6098h) to "-1: Return-to-home of our specifications."
4. Execute the Write batch NV memory (40C9h).
5. Turn on the control power supply of the driver again.
With these steps, the driver parameters will be prioritized.

■ Controlword of Homing Mode

Bit 15	Bit 14	Bit 13	Bit 12	Bit 11	Bit 10	Bit 9	Bit 8
Manufacturer specific (ms)					Reserved	oms	Halt
–	–	–	–	–		–	
Bit 7	Bit 6	Bit 5	Bit 4	Bit 3	Bit 2	Bit 1	Bit 0
Fault reset	Operation mode specific (oms)			Enable operation	Quick stop	Enable voltage	Switch on
	–	–	Homing operation start				

Details of Controlword

Bit	Name	Value	Description
8	Halt	0	Operation is allowed.
		1	Stop operation. The stopping method is based on the setting of the Halt option code (605Dh).
4	Homing operation start	0 → 1	<p>Start of return-to-home operation</p> <p>If the "Homing operation start" is set to 0 during return-to-home operation, the motor will decelerate to a stop.</p> <p>When the state is any of the following, the command is not received, and the operation is not started.</p> <ul style="list-style-type: none"> • During operation • The Halt (6040h: bit 8) has been set to 1. • The STOP input is being ON. • The drive state machine is other than "Operation enabled." • The motor is in a non-excitation state.

For bit 7 and bit 3 to bit 0, refer to "State transition of drive state machine" on p.72.

■ Statusword of Homing Mode

Bit 15	Bit 14	Bit 13	Bit 12	Bit 11	Bit 10	Bit 9	Bit 8
Manufacturer specific		Operation mode specific		Internal limit active	Target reached	Remote	ms
TLC	–	Homing error	Homing attained				–
Bit 7	Bit 6	Bit 5	Bit 4	Bit 3	Bit 2	Bit 1	Bit 0
Warning	Switch on disabled	Quick stop	Voltage enabled	Fault	Operation enabled	Switched on	Ready to switch on

● Details of Statusword

Bit	Name	Value	Description
15	TLC	0	A load does not reach the upper limit of the motor output torque.
		1	A load reached the upper limit of the motor output torque.
13	Homing error	0/1	Outputs the status of the motor based on a combination of values in the Homing error, Homing attained (6041h: bit 12), and Target reached (6041h: bit 10). Refer to the next table for details.
12	Homing attained	0/1	Outputs the status of the motor based on a combination of values in the Homing error (6041h: bit 13), Homing attained, and Target reached (6041h: bit 10). Refer to the next table for details.
11	Internal limit active	0	The function limitation by the internal limit is not in an active state.
		1	The function limitation by the internal limit became an active state. The value changes to 1 while any of the internal limit functions listed below are activated. <ul style="list-style-type: none"> • Limit sensor (FW-LS/RV-LS) • Operation prohibition input (FW-BLK/RV-BLK) • Software limit • Mechanism limit
10	Target reached	0/1	Outputs the status of the motor based on a combination of values in the Homing error (6041h: bit 13), Homing attained (6041h: bit 12), and Target reached. Refer to the next table for details.
9	Remote	1	The value changes to 1 when the initialization is completed.
7	Warning	0	Information is not generated. When the cause of information is cleared, the Warning is automatically cleared to 0.
		1	Information is being generated.

For bit 6 to bit 0, refer to "Status output of drive state machine" on p.73.

● Status output of motor

The status of the motor is output based on a combination of values in the Homing error (bit 13), Homing attained (bit 12), and Target reached (bit 10).

Homing error (Bit 13)	Homing attained (Bit 12)	Target reached (Bit 10)	Signal state
0	0	0	During operation of return-to-home operation
0	0	1	Return-to-home operation is interrupted, or it is not started.
0	1	0	– (Not generated)
0	1	1	Return-to-home operation was properly completed.
1	0	0	– (Not generated)
1	0	1	Interrupted since an alarm was generated during return-to-home operation.
1	1	0	Reserved
1	1	1	Reserved

■ Selection of return-to-home (Homing) method

The return-to-home method is selected with the Homing method (6098h). The driver supports the following methods to return to the home.

Homing method	Description
17	Return-to-home with the limit sensor (FW-LS/RV-LS), to start running in the negative direction.
18	Return-to-home with the limit sensor (FW-LS/RV-LS), to start running in the positive direction.
24	Return-to-home with the home sensor (HOMES), to start running in the positive direction.
28	Return-to-home with the home sensor (HOMES), to start in the negative direction.
35, 37*	Home preset
-1	Return-to-home operation of our specifications

* 35 and 37 perform the same action.

● Related objects

Index	Sub	Name	Type	Access	PDO	Save	Range	Update
6072h	00h	Max torque [1=0.1 %]	U16	RW	RxPDO	○	0 to 10,000 (Initial value: 1,000)	A
607Ch	00h	Home offset [step]	INT32	RW	No	○	-2,147,483,648 to 2,147,483,647 (Initial value: 0)	A
6098h	00h	Homing method	INT8	RW	No	○	17, 18, 24 (Initial value), 28, 35, 37, -1 (⇨ "Selection of return-to-home (Homing) method")	B
6099h	01h	Speed during search for switch [Hz]	U32	RW	No	○	1 to 4,000,000 (Initial value: 10,000)	B
	02h	Speed during search for zero [Hz]	U32	RW	No	○	1 to 10,000 (Initial value: 5,000)	B
609Ah	00h	Homing acceleration [step/s ²]	U32	RW	No	○	1 to 1,000,000,000 (Initial value: 300,000)	B
4163h	00h	(HOME) Return-to- home starting speed [Hz]	INT32	RW	No	○	1 to 4,000,000 (Initial value: 5,000)	B
4169h	00h	(HOME) Backward steps in 2 sensor return-to- home [step]	INT32	RW	No	○	0 to 8,388,607 (Initial value: 5,000)	B
41C6h	00h	Preset position [step]	INT32	RW	No	○	-2,147,483,648 to 2,147,483,647 (Initial value: 0)	A

- **Return-to-home operation of Oriental Motor's specifications**

When the Homing method (6098h) is set to -1, the return-to-home mode of Oriental Motor's specifications is applied.

Related objects (Oriental Motor's specifications)

Index	Sub	Name	Type	Access	PDO	Save	Range	Update
6072h	00h	Max torque [1=0.1 %]	U16	RW	RxPDO	○	0 to 10,000 (Initial value: 1,000)	A
607Ch	00h	Home offset [step]	INT32	RW	No	○	-2,147,483,648 to 2,147,483,647 (Initial value: 0)	A
6099h	01h	Speed during search for switch [Hz]	U32	RW	No	○	1 to 4,000,000 (Initial value: 10,000)	B
	02h	Speed during search for zero [Hz]	U32	RW	No	○	1 to 10,000 (Initial value: 5,000)	B
609Ah	00h	Homing acceleration [step/s ²]	U32	RW	No	○	1 to 1,000,000,000 (Initial value: 300,000)	B
4160h	00h	(HOME) Return-to- home mode	U8	RW	No	○	0: 2-sensor 1: 3-sensor 2: One-way rotation	B
4161h	00h	(HOME) Return-to- home starting direction	U8	RW	No	○	0: Negative side 1: Positive side (Initial value)	B
4163h	00h	(HOME) Return-to- home starting speed [Hz]	INT32	RW	No	○	1 to 4,000,000 (Initial value: 5,000)	B
4166h	00h	(HOME) Return-to- home SLIT detection	U8	RW	No	○	0: Disable (Initial value) 1: Enable	B
4167h	00h	(HOME) Return-to- home ZSG signal detection	U8	RW	No	○	0: Disable (Initial value) 2: ZSG	B
4168h	00h	(HOME) Return-to- home position offset [Hz]	INT32	RW	No	○	-2,147,483,647 to 2,147,483,647 (Initial value: 0)	B
4169h	00h	(HOME) Backward steps in 2 sensor return-to- home [step]	INT32	RW	No	○	0 to 8,388,607 (Initial value: 5,000)	B
416Ah	00h	(HOME) Operating amount in uni- directional return-to- home [step]	INT32	RW	No	○	0 to 8,388,607 (Initial value: 5,000)	B
41C6h	00h	Preset position [step]	INT32	RW	No	○	-2,147,483,648 to 2,147,483,647 (Initial value: 0)	A

■ Operation in Homing mode of CiA402 drive profile

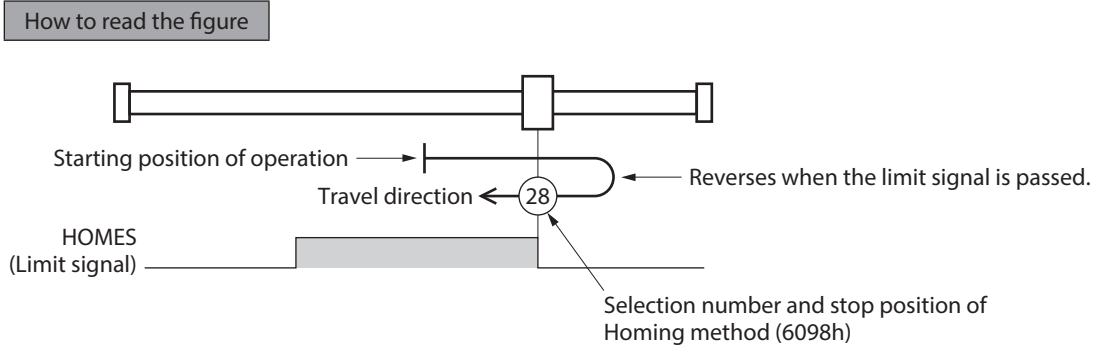

● Homing method:

24 [Return-to-home with the home sensor (HOMES), to start running in the positive direction]

When the HOME sensor is detected, the motor rotates in the reverse direction and pulls out of the HOME sensor at the (HOME) Return-to-home starting speed (4163h). After pulling out of the HOME sensor, the motor reverses once again, and continue to operate at the Speed during search for zero (6099h-02h). The motor stops when the ON edge of the HOME sensor is detected, and the position at which the motor stopped is set as the home. Refer to "Return-to-home operation sequence of 3-sensor mode" on p.98 for details of operation.

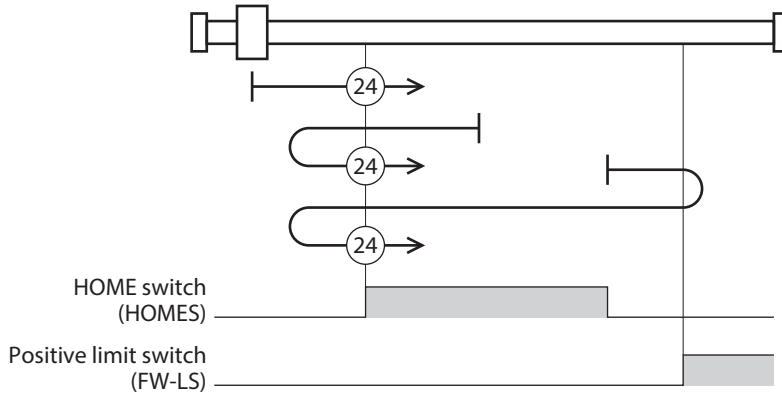

In the case of return-to-home operation of Oriental Motor's specifications, the same operation is performed if the following data is set.

- (HOME) Return-to-home mode (4160h): 1 [3-sensor]
- (HOME) Return-to-home starting direction (4161h): 1 [Positive side]
- (HOME) Return-to-home SLIT detection (4166h): 0 [Disable]
- (HOME) Return-to-home ZSG signal detection (4167h): 0 [Disable]

● **Homing method:**

28 [Return-to-home with the home sensor (HOMES), to start running in the negative direction]

When the HOME sensor is detected, the motor rotates in the reverse direction and pulls out of the HOME sensor at the (HOME) Return-to-home starting speed (4163h). After pulling out of the HOME sensor, the motor reverses once again, and continue to operate at the Speed during search for zero (6099h-02h). The motor stops when the ON edge of the HOME sensor is detected, and the position at which the motor stopped is set as the home. Refer to "Return-to-home operation sequence of 3-sensor mode" on p.98 for details of operation.

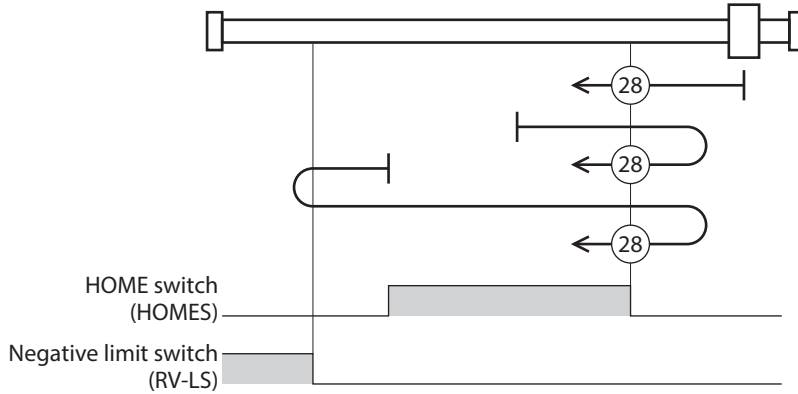

In the case of return-to-home operation of Oriental Motor's specifications, the same operation is performed if the following data is set.

- (HOME) Return-to-home mode (4160h): 1 [3-sensor]
- (HOME) Return-to-home starting direction (4161h): 0 [Negative side]
- (HOME) Return-to-home SLIT detection (4166h): 0 [Disable]
- (HOME) Return-to-home ZSG signal detection (4167h): 0 [Disable]

● **Homing method:**

17 [Return-to-home with the limit sensor (FW-LS/RV-LS), to start running in the negative direction]

After pulling out of the limit sensor, the motor rotates according to the value set in the (HOME) Backward steps in 2 sensor return-to-home (4169h) and stops. The position at which the motor stopped is set as the home. Refer to "Return-to-home operation sequence of 2-sensor mode" on p.100 for details of operation.

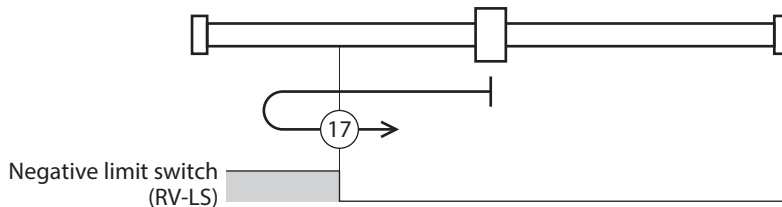

In the case of return-to-home operation of Oriental Motor's specifications, the same operation is performed if the following data is set.

- (HOME) Return-to-home mode (4160h): 0 [2-sensor]
- (HOME) Return-to-home starting direction (4161h): 0 [negative side]
- (HOME) Return-to-home SLIT detection (4166h): 0 [Disable]
- (HOME) Return-to-home ZSG signal detection (4167h): 0 [Disable]

- **Homing method:**

- **18 [Return-to-home with the limit sensor (FW-LS/RV-LS), to start running in the positive direction]**

After pulling out of the limit sensor, the motor rotates according to the value set in the (HOME) Backward steps in 2 sensor return-to-home (4169h) and stops. The position at which the motor stopped is set as the home. Refer to "Return-to-home operation sequence of 2-sensor mode" on p.100 for details of operation.

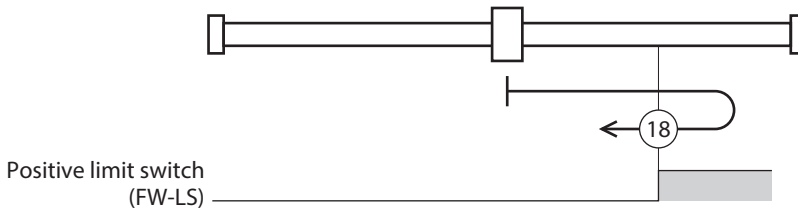

In the case of return-to-home operation of Oriental Motor's specifications, the same operation is performed if the following data is set.

- (HOME) Return-to-home mode (4160h): 0 [2-sensor]
- (HOME) Return-to-home starting direction (4161h): 1 [Positive side]
- (HOME) Return-to-home SLIT detection (4166h): 0 [Disable]
- (HOME) Return-to-home ZSG signal detection (4167h): 0 [Disable]

- **Homing method: 35, Homing method: 37 [Home preset]**

The present position is set as the home. The home preset can be executed except when the drive state machine is in a state of "Operation enabled." It can also be executed even when the motor is in a non-excitation state.

■ Operation in return-to-home mode of Oriental Motor's specifications

● Return-to-home operation sequence of 3-sensor mode

The motor operates at the Speed during search for switch (6099h-01h). When the limit sensor is detected during operation, the motor rotates in the reverse direction and pulls out of the limit sensor. The motor stops when the ON edge of the HOME sensor is detected, and the position at which the motor stopped is set as the home.

Explanation of code	<ul style="list-style-type: none"> ● VR: Speed during search for switch (6099h-01h) ● VS: (HOME) Return-to-home starting speed (4163h) ● VL: Speed during search for zero (6099h-02h) ● - - -: Orbit when the home offset is set
---------------------	--

Starting position of return-to-home operation	Starting direction of return-to-home operation: Positive direction	Starting direction of return-to-home operation: Negative direction
RV-LS		
FW-LS		
HOMES		
Between HOMES and RV-LS		
Between HOMES and FW-LS		

When the SLIT input and/or the ZSG signal are used concurrently

Even after return-to-home operation is completed, operation is continued until an external signal is detected. If an external signal is detected while the HOME sensor is ON, return-to-home operation is completed.

Explanation of code	<ul style="list-style-type: none"> • VR: Speed during search for switch (6099h-01h) • VS: (HOME) Return-to-home starting speed (4163h) • VL: Speed during search for zero (6099h-02h) • - - -: Orbit when the home offset is set
---------------------	--

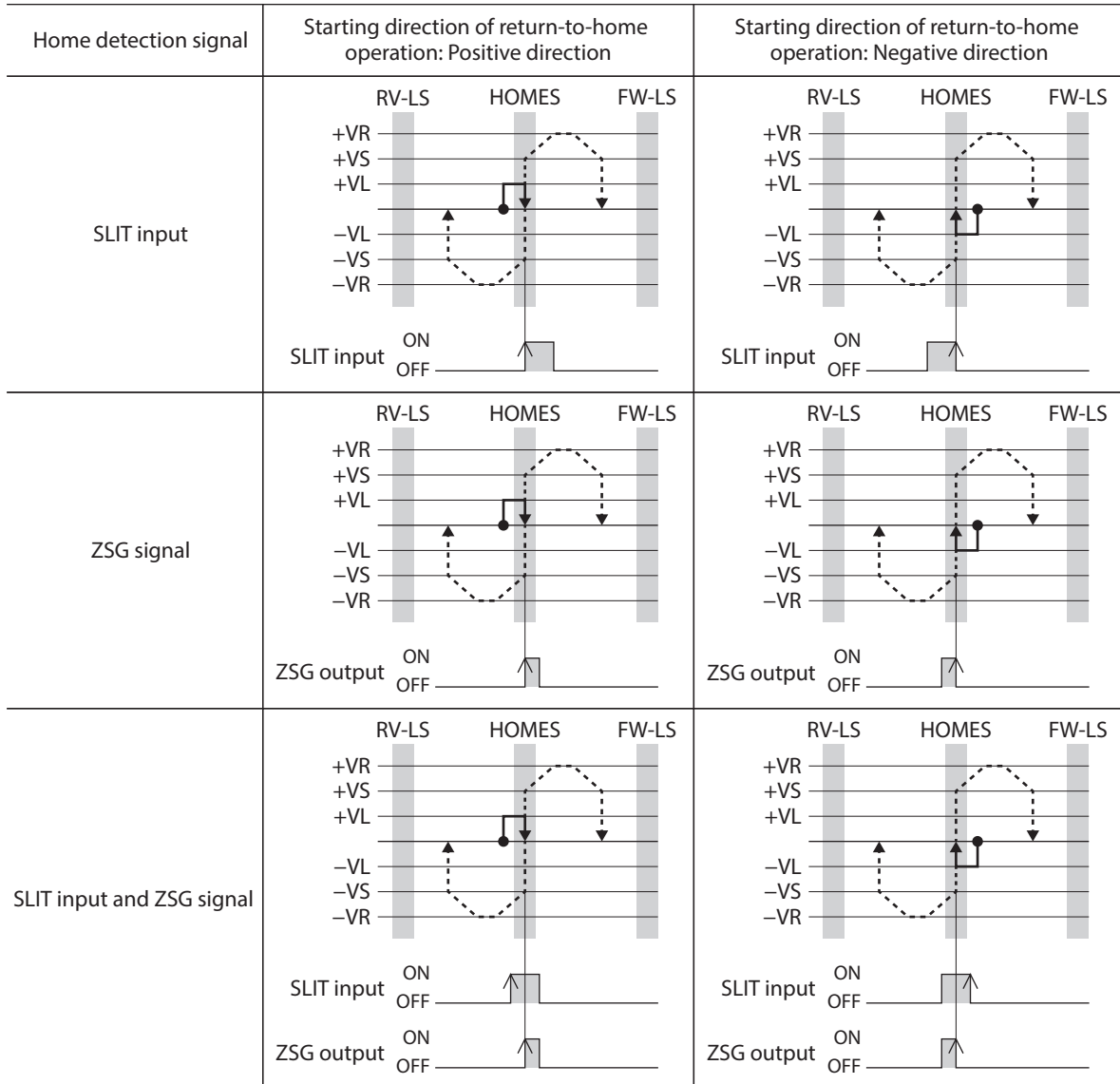

● **Return-to-home operation sequence of 2-sensor mode**

The motor operates at the (HOME) Return-to-home starting speed (4163h). When the limit sensor is detected, the motor rotates in the reverse direction and pulls out of the limit sensor.

After pulling out of the limit sensor, the motor rotates according to the value set in the (HOME) Backward steps in 2 sensor return-to-home (4169h) and stops. The position at which the motor stopped is set as the home.

Explanation of code	<ul style="list-style-type: none"> ● VR: Speed during search for switch (6099h-01h) ● VS: (HOME) Return-to-home starting speed (4163h) ● VL: Speed during search for zero (6099h-02h) ● - - -: Orbit when the home offset is set
---------------------	--

Starting position of return-to-home operation	Starting direction of return-to-home operation: Positive direction	Starting direction of return-to-home operation: Negative direction
RV-LS		
FW-LS		
Between RV-LS and FW-LS		

* After pulling out of the limit sensor, the motor rotates according to the value set in the (HOME) Backward steps in 2 sensor return-to-home (4169h) and stops.

When the SLIT input and/or the ZSG signal are used concurrently

Even after return-to-home operation is completed, operation is continued until an external signal is detected. If an external signal is detected, return-to-home operation is completed.

Explanation of code	<ul style="list-style-type: none"> • VR: Speed during search for switch (6099h-01h) • VS: (HOME) Return-to-home starting speed (4163h) • VL: Speed during search for zero (6099h-02h) • - - -: Orbit when the home offset is set
---------------------	--

Home detection signal	Starting direction of return-to-home operation: Positive direction	Starting direction of return-to-home operation: Negative direction
SLIT input		
ZSG signal		
SLIT input and ZSG signal		

* After pulling out of the limit sensor, the motor rotates according to the value set in the (HOME) Backward steps in 2 sensor return-to-home (4169h) and stops.

● **One-way rotation mode**

The motor operates at the Speed during search for switch (6099h-01h). When the HOME sensor is detected, the motor decelerates to a stop and pulls out of the HOME sensor at the Speed during search for zero (6099h-02h). After pulling out of the limit sensor, the motor rotates according to the value set in the (HOME) Operating amount in uni-directional return-to-home (416Ah) and stops. The position at which the motor stopped is set as the home.

Explanation of code	<ul style="list-style-type: none"> ● VR: Speed during search for switch (6099h-01h) ● VS: (HOME) Return-to-home starting speed (4163h) ● VL: Speed during search for zero (6099h-02h) ● - - -: Orbit when the home offset is set
---------------------	--

Starting position of return-to-home operation	Starting direction of return-to-home operation: Positive direction	Starting direction of return-to-home operation: Negative direction
HOMES		
Other than HOMES		

* After pulling out of the HOME sensor, the motor rotates according to the value set in the (HOME) Operating amount in uni-directional return-to-home (416Ah) and stops.

memo If the motor pulls out of the HOME sensor during deceleration stop after the HOME sensor has been detected, an alarm of Return-to-home error (alarm code 62h) is generated. Set the Homing acceleration (609Ah) so that the motor can stop in the range of the HOME sensor.

When the SLIT input and/or the ZSG signal are used concurrently

Even after return-to-home operation is completed, operation is continued until an external signal is detected. If an external signal is detected, return-to-home operation is completed.

Explanation of code	<ul style="list-style-type: none"> • VR: Speed during search for switch (6099h-01h) • VS: (HOME) Return-to-home starting speed (4163h) • VL: Speed during search for zero (6099h-02h) • - - -: Orbit when the home offset is set
---------------------	--

Home detection signal	Starting direction of return-to-home operation: Positive direction	Starting direction of return-to-home operation: Negative direction
SLIT input		
ZSG signal		
SLIT input and ZSG signal		

* After pulling out of the HOME sensor, the motor rotates according to the value set in the (HOME) Operating amount in uni-directional return-to-home (416Ah) and stops.

4 Functions

4-1 Touch probe

The touch probe is a function that sets the external latch input signal (EXT1 input, EXT2 input) or the output signal (ZSG output) as a trigger and latches the position when the trigger is input. For the position to latch, either the internal command position or the position actual value can be selected. The touch probe has the touch probe 1 and touch probe 2.

● Related objects

Index	Sub	Name	Type	Access	PDO	Save	Range	Update
60B8h	00h	Touch probe function	U16	RW	RxPDO	–	0000h to FFFFh (Initial value: 0000h)	A
60B9h	00h	Touch probe status	U16	RO	TxPDO	–	–	–
60BAh	00h	Touch probe position 1 positive value [step]	INT32	RO	TxPDO	–	–	–
60BBh	00h	Touch probe position 1 negative value [step]	INT32	RO	TxPDO	–	–	–
60BCh	00h	Touch probe position 2 positive value [step]	INT32	RO	TxPDO	–	–	–
60BDh	00h	Touch probe position 2 negative value [step]	INT32	RO	TxPDO	–	–	–
44B0h	00h	Touch probe 1 latch position	U8	RW	No	–	0: Latches the position actual value (feedback position) (Initial value) 1: Latches the command position	A
44B1h	00h	Touch probe 2 latch position	U8	RW	No	–	0: Latches the position actual value (feedback position) (Initial value) 1: Latches the command position	A

● Related signals

Signal name	Description
EXT1 input	This is an external latch input signal for the touch probe 1.
EXT2 input	This is an external latch input signal for the touch probe 2.
ZSG output	This signal can be used in the touch probe 1 and touch probe 2.

■ Details of touch probe function

The action of the touch probe is set with the Touch probe function (60B8h).

Set the action of the touch probe 1 in the lower 8 bits and that of the touch probe 2 in the upper 8 bits.

Set the trigger condition using the Touch probe 1 trigger action / Touch probe 2 trigger action (bit 1 / bit 9) and the Touch probe 1 trigger selection / Touch probe 2 trigger selection (bit 2 / bit 10). After that, changing the Touch probe 1 permission / Touch probe 2 permission (bit 0 / bit 8) from 0 to 1 latches according to the set trigger condition.

Be sure to change the Touch probe 1 permission / Touch probe 2 permission (bit 0 / bit 8) back to 0 before changing the trigger condition. Changing the trigger condition while the Touch probe 1 permission / Touch probe 2 permission (bit 0 / bit 8) remains 1 will not be enabled.

Bit	Name	Value	Description
0	Touch probe 1 permission	0	Disables the touch probe 1.
		1	Enables the touch probe 1.
1	Touch probe 1 trigger action	0	First trigger action Latches only once on the first trigger.
		1	Continuous action Latches every time a trigger is input.
2	Touch probe 1 trigger selection	0	Sets the external latch input EXT1 as a trigger.
		1	Sets the ZSG output as a trigger.
3	Reserved	0	Reserved
4	Touch probe 1 positive value action	0	Disables the latch function on the positive value of a trigger.
		1	Enables the latch function on the positive value of a trigger.
5	Touch probe 1 negative value action	0	Disables the latch function on the negative value of a trigger.
		1	Enables the latch function on the negative value of a trigger.
6	Reserved	0	Reserved
7	Reserved	0	Reserved
8	Touch probe 2 permission	0	Disables the touch probe 2.
		1	Enables the touch probe 2.
9	Touch probe 2 trigger action	0	First trigger action Latches only once on the first trigger.
		1	Continuous action Latches every time a trigger is input.
10	Touch probe 2 trigger selection	0	Sets the external latch input EXT2 as a trigger.
		1	Sets the ZSG output as a trigger.
11	Reserved	0	Reserved
12	Touch probe 2 positive value action	0	Disables the latch function on the positive value of a trigger.
		1	Enables the latch function on the positive value of a trigger.
13	Touch probe 2 negative value action	0	Disables the latch function on the negative value of a trigger.
		1	Enables the latch function on the negative value of a trigger.
14	Reserved	0	Reserved
15	Reserved	0	Reserved

■ Details of touch probe status

The status of the touch probe is output by the Touch probe status (60B9h).

The status of the touch probe 1 is output in the lower 8 bits, and that of the touch probe 2 is output in the upper 8 bits.

Bit	Name	Value	Description
0	Touch probe 1 permission status	0	The touch probe 1 is disabled.
		1	The touch probe 1 is enabled.
1	Touch probe 1 positive value latch	0	Has not latch on the positive value of the touch probe 1.
		1	Latched on the positive value of the touch probe 1.
2	Touch probe 1 negative value latch	0	Has not latch on the negative value of the touch probe 1.
		1	Latched on the negative value of the touch probe 1.
3 to 7	Reserved	0	Reserved
8	Touch probe 2 permission status	0	The touch probe 2 is disabled.
		1	The touch probe 2 is enabled.
9	Touch probe 2 positive value latch	0	Has not latch on the positive value of the touch probe 2.
		1	Latched on the positive value of the touch probe 2.
10	Touch probe 2 negative value latch	0	Has not latch on the negative value of the touch probe 2.
		1	Latched on the negative value of the touch probe 2.
11 to 15	Reserved	0	Reserved

■ Trigger and latch position

Select the signal that is set as a trigger with the Trigger selection (bit 2 / bit 10) of the Touch probe function (60B8h). The latch position varies depending on the signal that is set as a trigger. When the external latch input (EXT1 input, EXT2 input) is set as a trigger, the latch position can be set to either the position actual value (feedback position) or the internal command position.

Signal name	Latch position
External latch input	Position actual value (feedback position) or internal command position (Select by the Touch probe latch position (44B0h/44B1h))
ZSG output	Position actual value (Feedback position)

Related objects

Index	Sub	Object name	Initial value	Description
44B0h	00h	Touch probe 1 latch position	0	0: Latches the position actual value (feedback position) (Initial value) 1: Latches the command position
44B1h	00h	Touch probe 2 latch position	0	

■ Operation sequence of touch probe

The operation examples of the touch probe 1 are shown below.

● When the trigger action is "First trigger action" (60B8h: bit 1 is 0)

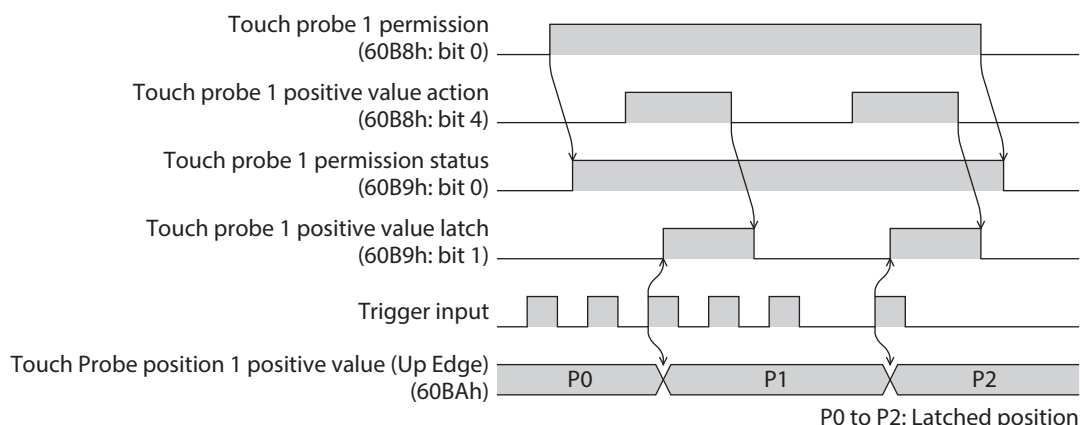

● When the trigger action is "Continuous action" (60B8h: bit 1 is 1)

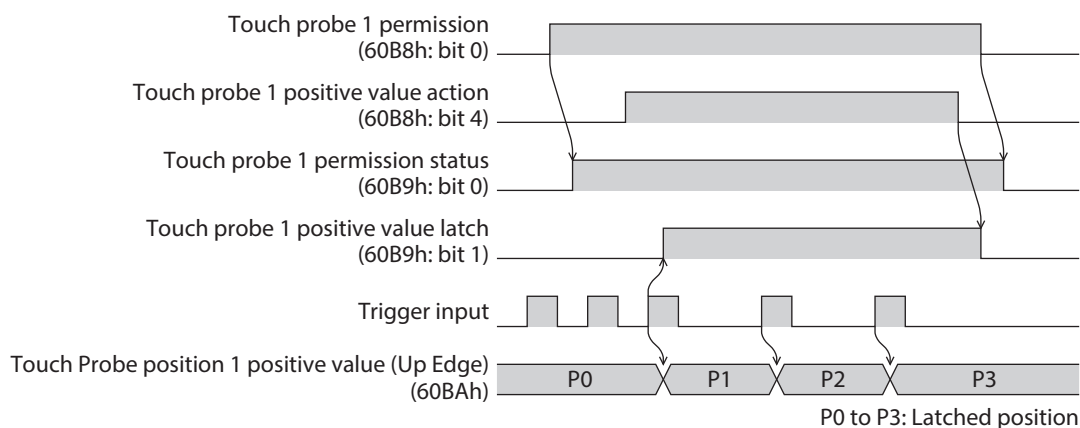

4-2 Resolution

When the Gear ratio (6091h) is set, the resolution per revolution of the motor output shaft can be set.

- Resolution of the motor output shaft = $10,000 \times \text{Electronic gear B (6091h-02h)} / \text{Electronic gear A (6091h-01h)}$
- Factory setting: 10,000 P/R
- Setting range: 100 to 10,000 P/R

Related objects

Index	Sub	Name	Type	Access	PDO	Save	Range	Update
6091h	00h	Number of entries	U8	RO	No	—	2	—
	01h	Electronic gear A	U32	RW	No	○	1 to 65,535 (Initial value: 1)	C
	02h	Electronic gear B	U32	RW	No	○	1 to 65,535 (Initial value: 1)	C



- If a value out of the setting range is set, information of Electronic gear setting error is generated (information code 2000h). If the control power supply is turned on again or Configuration is executed in a state where information of Electronic gear setting error is being generated, an alarm of Electronic gear setting error will be generated (alarm code 71h).
- If the resolution was changed after preset was executed in a state where the Home offset (607Ch) is other than 0, execute preset again. When the Home offset (607Ch) is 0, it is no need to execute preset again even if the resolution is changed. (The present position is calculated automatically.)

4-3 Wrap function

The wrap function is a function to automatically preset the position information of the present position when the number of revolutions of the motor output shaft exceeds the set range. Setting the wrap offset can restrict the operation area of equipment or control an index table with coordinates on the positive and negative sides.

Related objects

Index	Sub	Name	Type	Access	PDO	Save	Range	Update
41C7h	00h	Wrap (RND) setting	U8	RW	No	<input type="radio"/>	0: Disable 1: Enable (Initial value)	C
41C9h	00h	Initial coordinate generation & wrap setting range [1=0.1 rev]	INT32	RW	No	<input type="radio"/>	5 to 655,360 (Initial value: 10)	C
41CBh	00h	Initial coordinate generation & wrap range offset ratio [1=0.01 %]	U16	RW	No	<input type="radio"/>	0 to 10,000 (Initial value: 5,000)	C
41CCh	00h	Initial coordinate generation & wrap range offset value [step]	INT32	RW	No	<input type="radio"/>	-536,870,912 to 536,870,911 (Initial value: 0)	C

4-4 Maintenance commands

Maintenance commands are used to perform alarm reset, position preset (P-PRESET), batch processing for the non-volatile memory, and others.



The maintenance commands include processing in which the memory is operated, such as batch processing for the non-volatile memory and position preset (P-PRESET). Be careful not to execute them unnecessarily in succession.

Related objects

Index	Sub	Name	Description
40C0h	00h	Alarm reset	Resets the alarm being generated presently. Some alarms cannot be reset.
40C2h	00h	Clear alarm history	Clears the alarm history.
40C5h	00h	P-PRESET execution	Presets the command position.
40C6h	00h	Configuration	Executes recalculation and setup of the parameter.
40C8h	00h	Read batch NV memory	Reads the parameters stored in the non-volatile memory to the RAM. All parameters stored in the RAM are overwritten.
40C9h	00h	Write batch NV memory	Writes the parameters stored in the RAM to the non-volatile memory. The non-volatile memory can be rewritten approximately 100,000 times.
40CAh	00h	All data batch initialization	Restores the parameters stored in the non-volatile memory to their initial values.
40CBh	00h	Read from backup	Reads all the data from the backup area.
40CCh	00h	Write to backup	Writes all the data to the backup area.
40CDh	00h	Clear latch information	Clears the cumulative load. This is used when the Cumulative load value auto clear (41B3h) is set to "0: Disable."
40CFh	00h	Clear tripmeter	Clears the tripmeter.
40D0h	00h	Execute ETO-CLR input	Puts the motor in a state where it can be excited after the power removal function is released.
40D1h	00h	ZSG-PRESET	Sets the position of phase Z again.
40D2h	00h	Clear ZSG-PRESET	Clears the position data of phase Z that was set again with the ZSG-PRESET (40D1h).
40D3h	00h	Clear information	Clears the information.
40D4h	00h	Clear information history	Clears the information history.

■ How to execute the maintenance commands

The following two methods are available to execute maintenance commands. Use them selectively in accordance with the intended use.

● Write 1 to data (recommended)

When data is changed from 0 to 1 after 1 is written to it, the command is executed.

To execute the same command again, restore the data to 0 and then write 1. It is safe because the command is not executed in succession even if 1 is consecutively written from the EtherCAT MainDevice.

● Write 2 to data

When 2 is written to data, the command is executed. After execution, the data is restored to 1 automatically. Data does not need to restore to 1, and it can be written consecutively.

If commands which take time to write to the non-volatile memory, such as Write batch NV memory (40C9h), are executed consecutively, increase the length of the intervals between commands.

■ Configuration

Configuration can be executed when all of the following conditions are satisfied.

- An alarm is not being generated.
- The motor is not operated.
- I/O test, remote operation, and download are not being executed with the **MEXE02**.

The table below shows the driver status before and after Configuration is executed.

Item	Configuration is ready to execute	Configuration is being executed	After Configuration is executed
PWR/ALM LED	Green light	Blink in green and red colors simultaneously*	Based on the driver condition.
Electromagnetic brake	Hold/Release	Hold	
Motor excitation	Excitation/non-excitation	Non-excitation	
Output signal	Enable	Disable	Enable
Input signal	Enable	Disable	Enable

* Green and red colors may overlap and it may be visible to orange.



Even if monitor is executed while Configuration is being executed, the correct monitor value may not return.

4-5 Assignment of I/O functions

This section explains the assignment of I/O functions and internal I/O status.

■ Assignment to input terminals

Input signals can be assigned to the input terminals IN0 to IN5. Refer to p.115 for signals that can be assigned.

Related objects

Index	Sub	Name	Type	Access	PDO	Save	Range	Update
4840h	00h	DIN0 input function	U8	RW	No	○	0 to 127 [Initial value: 30 (HOMES)]	C
4841h	00h	DIN1 input function	U8	RW	No	○	0 to 127 [Initial value: 1 (FREE)]	C
4842h	00h	DIN2 input function	U8	RW	No	○	0 to 127 [Initial value: 12 (ETO-CLR)]	C
4843h	00h	DIN3 input function	U8	RW	No	○	0 to 127 [Initial value: 104 (EXT1)]	C
4844h	00h	DIN4 input function	U8	RW	No	○	0 to 127 [Initial value: 28 (FW-LS)]	C
4845h	00h	DIN5 input function	U8	RW	No	○	0 to 127 [Initial value: 29 (RV-LS)]	C

■ Assignment to output terminals

Output signals can be assigned to the output terminals OUT0 to OUT5 of the driver. Refer to p.116 for signals that can be assigned.

Related objects

Index	Sub	Name	Type	Access	PDO	Save	Range	Update
4860h	00h	DOUT0 (Normal) output function	U8	RW	No	○	0 to 255 [Initial value: 144 (HOME-END)]	C
4861h	00h	DOUT1 (Normal) output function	U8	RW	No	○	0 to 255 [Initial value: 137 (ETO-MON)]	C
4862h	00h	DOUT2 (Normal) output function	U8	RW	No	○	0 to 255 [Initial value: 0 (No function)]	C
4863h	00h	DOUT3 (Normal) output function	U8	RW	No	○	0 to 255 [Initial value: 142 (SON-MON)]	C
4864h	00h	DOUT4 (Normal) output function	U8	RW	No	○	0 to 255 [Initial value: 134 (MOVE)]	C
4865h	00h	DOUT5 (Normal) output function	U8	RW	No	○	0 to 255 [Initial value: 130 (ALM-B)]	C

■ Direct I/O

The status of direct I/O can be checked with the Direct I/O (406Ah). The arrangement of bits is as follows.

Bit 31	Bit 30	Bit 29	Bit 28	Bit 27	Bit 26	Bit 25	Bit 24
BSG	ASG	–	–	–	–	–	–
Bit 23	Bit 22	Bit 21	Bit 20	Bit 19	Bit 18	Bit 17	Bit 16
–	–	OUT5	OUT4	OUT3	OUT2	OUT1	OUT0
Bit 15	Bit 14	Bit 13	Bit 12	Bit 11	Bit 10	Bit 9	Bit 8
VR-IN3	VR-IN2	VR-IN1	VR-IN0	–	EXT-IN	–	–
Bit 7	Bit 6	Bit 5	Bit 4	Bit 3	Bit 2	Bit 1	Bit 0
–	–	IN5	IN4	IN3	IN2	IN1	IN0

Related object

Index	Sub	Name	Type	Access	PDO	Save	Range	Update
406Ah	00h	Direct I/O	U32	RO	TxPDO	–	–	–

■ I/O status

The status of the I/O inside the driver can be monitored with the I/O status. The arrangement of bits for the internal I/O is as follows.

Driver object	Description							
I/O status 1 (40B8h)	Bit 31	Bit 30	Bit 29	Bit 28	Bit 27	Bit 26	Bit 25	Bit 24
	SLIT	HOMES	RV-LS	FW-LS	RV-BLK	FW-BLK	–	–
	Bit 23	Bit 22	Bit 21	Bit 20	Bit 19	Bit 18	Bit 17	Bit 16
	SPD-LMT	TRQ-LMT	–	–	–	–	–	HMI
	Bit 15	Bit 14	Bit 13	Bit 12	Bit 11	Bit 10	Bit 9	Bit 8
	–	INFO-CLR	LAT-CLR	ETO-CLR	–	–	P-PRESET	ALM-RST
	Bit 7	Bit 6	Bit 5	Bit 4	Bit 3	Bit 2	Bit 1	Bit 0
–	–	STOP	–	CLR	–	FREE	No function	
I/O status 2 (40B9h)	Bit 31	Bit 30	Bit 29	Bit 28	Bit 27	Bit 26	Bit 25	Bit 24
	–	–	–	–	–	–	–	–
	Bit 23	Bit 22	Bit 21	Bit 20	Bit 19	Bit 18	Bit 17	Bit 16
	–	–	–	–	–	–	–	–
	Bit 15	Bit 14	Bit 13	Bit 12	Bit 11	Bit 10	Bit 9	Bit 8
	–	–	–	–	–	–	–	–
	Bit 7	Bit 6	Bit 5	Bit 4	Bit 3	Bit 2	Bit 1	Bit 0
–	–	–	–	–	–	–	–	
I/O status 3 (40BAh)	Bit 31	Bit 30	Bit 29	Bit 28	Bit 27	Bit 26	Bit 25	Bit 24
	R15	R14	R13	R12	R11	R10	R9	R8
	Bit 23	Bit 22	Bit 21	Bit 20	Bit 19	Bit 18	Bit 17	Bit 16
	R7	R6	R5	R4	R3	R2	R1	R0
	Bit 15	Bit 14	Bit 13	Bit 12	Bit 11	Bit 10	Bit 9	Bit 8
	–	–	–	–	–	–	–	–
	Bit 7	Bit 6	Bit 5	Bit 4	Bit 3	Bit 2	Bit 1	Bit 0
–	–	–	–	–	–	–	–	
I/O status 4 (40BBh)	Bit 31	Bit 30	Bit 29	Bit 28	Bit 27	Bit 26	Bit 25	Bit 24
	–	–	–	–	–	–	–	–
	Bit 23	Bit 22	Bit 21	Bit 20	Bit 19	Bit 18	Bit 17	Bit 16
	–	–	–	–	–	–	–	–
	Bit 15	Bit 14	Bit 13	Bit 12	Bit 11	Bit 10	Bit 9	Bit 8
	–	–	–	–	–	–	EXT2	EXT1
	Bit 7	Bit 6	Bit 5	Bit 4	Bit 3	Bit 2	Bit 1	Bit 0
–	–	–	–	–	–	–	–	
I/O status 5 (40BCh)	Bit 31	Bit 30	Bit 29	Bit 28	Bit 27	Bit 26	Bit 25	Bit 24
	–	–	–	RND-ZERO	ZSG	RV-SLS	FW-SLS	RND-OVF
	Bit 23	Bit 22	Bit 21	Bit 20	Bit 19	Bit 18	Bit 17	Bit 16
	ORGN-STLD	PRST-STLD	PRST-DIS	–	–	–	ABSPEN	HOME-END
	Bit 15	Bit 14	Bit 13	Bit 12	Bit 11	Bit 10	Bit 9	Bit 8
	–	SON-MON	VA	TLC	ZV	IN-POS	ETO-MON	SYS-BSY
	Bit 7	Bit 6	Bit 5	Bit 4	Bit 3	Bit 2	Bit 1	Bit 0
INFO	MOVE	–	READY	SYS-RDY	ALM-B	ALM-A	CONST-OFF	

Driver object	Description							
I/O status 6 (40BDh)	Bit 31	Bit 30	Bit 29	Bit 28	Bit 27	Bit 26	Bit 25	Bit 24
	–	–	–	–	–	–	–	–
	Bit 23	Bit 22	Bit 21	Bit 20	Bit 19	Bit 18	Bit 17	Bit 16
	–	–	USR-OUT1	USR-OUT0	–	–	–	–
	Bit 15	Bit 14	Bit 13	Bit 12	Bit 11	Bit 10	Bit 9	Bit 8
	–	–	HWTOIN-MON	EDM-MON	–	RG	MBC	MPS
	Bit 7	Bit 6	Bit 5	Bit 4	Bit 3	Bit 2	Bit 1	Bit 0
AREA7	AREA6	AREA5	AREA4	AREA3	AREA2	AREA1	AREA0	
I/O status 7 (40BEh)	Bit 31	Bit 30	Bit 29	Bit 28	Bit 27	Bit 26	Bit 25	Bit 24
	–	–	–	–	–	–	–	–
	Bit 23	Bit 22	Bit 21	Bit 20	Bit 19	Bit 18	Bit 17	Bit 16
	–	–	–	–	–	–	–	–
	Bit 15	Bit 14	Bit 13	Bit 12	Bit 11	Bit 10	Bit 9	Bit 8
	–	OL-DTCT	DCMD-FULL	DCMD-RDY	–	–	–	–
	Bit 7	Bit 6	Bit 5	Bit 4	Bit 3	Bit 2	Bit 1	Bit 0
–	–	–	OPE-BSY	–	–	SPD-LMTD	TRQ-LMTD	
I/O status 8 (40BFh)	Bit 31	Bit 30	Bit 29	Bit 28	Bit 27	Bit 26	Bit 25	Bit 24
	INFO-RBT	INFO-CFG	INFO-IOTEST	INFO-DSLMTD	–	–	–	INFO-STLTIME
	Bit 23	Bit 22	Bit 21	Bit 20	Bit 19	Bit 18	Bit 17	Bit 16
	INFO-TRQ	–	INFO-ODO	INFO-TRIP	INFO-CULD1	INFO-CULD0	INFO-RV-OT	INFO-FW-OT
	Bit 15	Bit 14	Bit 13	Bit 12	Bit 11	Bit 10	Bit 9	Bit 8
	–	INFO-RND-E	INFO-EGR-E	–	INFO-PR-REQ	INFO-ZHOME	INFO-START	INFO-SPD
	Bit 7	Bit 6	Bit 5	Bit 4	Bit 3	Bit 2	Bit 1	Bit 0
INFO-LOAD	INFO-TLCTIME	INFO-UVOLT	INFO-OVOLT	INFO-MTRTMP	INFO-DRVTMP	INFO-POSERR	INFO-USRIO	

Related objects

Index	Sub	Name	Type	Access	PDO	Save	Range	Update
40B8h	00h	I/O status 1	U32	RO	TxPDO	–	–	–
40B9h	00h	I/O status 2	U32	RO	TxPDO	–	–	–
40BAh	00h	I/O status 3	U32	RO	TxPDO	–	–	–
40BBh	00h	I/O status 4	U32	RO	TxPDO	–	–	–
40BCh	00h	I/O status 5	U32	RO	TxPDO	–	–	–
40BDh	00h	I/O status 6	U32	RO	TxPDO	–	–	–
40BEh	00h	I/O status 7	U32	RO	TxPDO	–	–	–
40BFh	00h	I/O status 8	U32	RO	TxPDO	–	–	–

■ Driver input command

The Driver input command (403Eh) is an input command from the EtherCAT MainDevice to the driver. The arrangement of bits is as follows.

Bit 0 to Bit 15 are assigned to the R-IN0 to R-IN15.

(): Initial value

Bit 15	Bit 14	Bit 13	Bit 12	Bit 11	Bit 10	Bit 9	Bit 8
R-IN15 (No function)	R-IN14 (No function)	R-IN13 (No function)	R-IN12 (No function)	R-IN11 (No function)	R-IN10 (No function)	R-IN9 (No function)	R-IN8 (No function)
Bit 7	Bit 6	Bit 5	Bit 4	Bit 3	Bit 2	Bit 1	Bit 0
R-IN7 (No function)	R-IN6 (No function)	R-IN5 (No function)	R-IN4 (No function)	R-IN3 (No function)	R-IN2 (No function)	R-IN1 (No function)	R-IN0 (No function)

Related objects

Refer to p.115 for signals that can be assigned.

Index	Sub	Name	Type	Access	PDO	Save	Range	Update
4900h	00h	R-IN0 input function	U8	RW	No	○	0 to 127 [Initial value: 0 (No function)]	C
4901h	00h	R-IN1 input function	U8	RW	No	○	0 to 127 [Initial value: 0 (No function)]	C
4902h	00h	R-IN2 input function	U8	RW	No	○	0 to 127 [Initial value: 0 (No function)]	C
4903h	00h	R-IN3 input function	U8	RW	No	○	0 to 127 [Initial value: 0 (No function)]	C
4904h	00h	R-IN4 input function	U8	RW	No	○	0 to 127 [Initial value: 0 (No function)]	C
4905h	00h	R-IN5 input function	U8	RW	No	○	0 to 127 [Initial value: 0 (No function)]	C
4906h	00h	R-IN6 input function	U8	RW	No	○	0 to 127 [Initial value: 0 (No function)]	C
4907h	00h	R-IN7 input function	U8	RW	No	○	0 to 127 [Initial value: 0 (No function)]	C
4908h	00h	R-IN8 input function	U8	RW	No	○	0 to 127 [Initial value: 0 (No function)]	C
4909h	00h	R-IN9 input function	U8	RW	No	○	0 to 127 [Initial value: 0 (No function)]	C
490Ah	00h	R-IN10 input function	U8	RW	No	○	0 to 127 [Initial value: 0 (No function)]	C
490Bh	00h	R-IN11 input function	U8	RW	No	○	0 to 127 [Initial value: 0 (No function)]	C
490Ch	00h	R-IN12 input function	U8	RW	No	○	0 to 127 [Initial value: 0 (No function)]	C
490Dh	00h	R-IN13 input function	U8	RW	No	○	0 to 127 [Initial value: 0 (No function)]	C
490Eh	00h	R-IN14 input function	U8	RW	No	○	0 to 127 [Initial value: 0 (No function)]	C
490Fh	00h	R-IN15 input function	U8	RW	No	○	0 to 127 [Initial value: 0 (No function)]	C

■ **Driver status**

The status of the R-OUT0 to R-OUT15 can be checked with the Driver status (403Fh). The arrangement of bits is as follows.

(): Initial value

Bit 15	Bit 14	Bit 13	Bit 12	Bit 11	Bit 10	Bit 9	Bit 8
R-OUT15 (TLC)	R-OUT14 (IN-POS)	R-OUT13 (MOVE)	R-OUT12 (No function)	R-OUT11 (AREA2)	R-OUT10 (AREA1)	R-OUT9 (AREA0)	R-OUT8 (SYS-BSY)
Bit 7	Bit 6	Bit 5	Bit 4	Bit 3	Bit 2	Bit 1	Bit 0
R-OUT7 (ALM-A)	R-OUT6 (INFO)	R-OUT5 (DCMD-RDY)	R-OUT4 (HOME-END)	R-OUT3 (No function)	R-OUT2 (ZSG)	R-OUT1 (RV-LS_R)	R-OUT0 (FW-LS_R)

Related objects

Refer to p.116 for signals that can be assigned.

Index	Sub	Name	Type	Access	PDO	Save	Range	Update
4910h	00h	R-OUT0 output function	U8	RW	No	○	0 to 255 [Initial value: 28 (FW-LS_R)]	C
4911h	00h	R-OUT1 output function	U8	RW	No	○	0 to 255 [Initial value: 29 (RV-LS_R)]	C
4912h	00h	R-OUT2 output function	U8	RW	No	○	0 to 255 [Initial value: 155 (ZSG)]	C
4913h	00h	R-OUT3 output function	U8	RW	No	○	0 to 255 [Initial value: 0 (No function)]	C
4914h	00h	R-OUT4 output function	U8	RW	No	○	0 to 255 [Initial value: 144 (HOME-END)]	C
4915h	00h	R-OUT5 output function	U8	RW	No	○	0 to 255 [Initial value: 204 (DCMD-RDY)]	C
4916h	00h	R-OUT6 output function	U8	RW	No	○	0 to 255 [Initial value: 135 (INFO)]	C
4917h	00h	R-OUT7 output function	U8	RW	No	○	0 to 255 [Initial value: 129 (ALM-A)]	C
4918h	00h	R-OUT8 output function	U8	RW	No	○	0 to 255 [Initial value: 136 (SYS-BSY)]	C
4919h	00h	R-OUT9 output function	U8	RW	No	○	0 to 255 [Initial value: 160 (AREA0)]	C
491Ah	00h	R-OUT10 output function	U8	RW	No	○	0 to 255 [Initial value: 161 (AREA1)]	C
491Bh	00h	R-OUT11 output function	U8	RW	No	○	0 to 255 [Initial value: 162 (AREA2)]	C
491Ch	00h	R-OUT12 output function	U8	RW	No	○	0 to 255 [Initial value: 0 (No function)]	C
491Dh	00h	R-OUT13 output function	U8	RW	No	○	0 to 255 [Initial value: 134 (MOVE)]	C
491Eh	00h	R-OUT14 output function	U8	RW	No	○	0 to 255 [Initial value: 138 (IN-POS)]	C
491Fh	00h	R-OUT15 output function	U8	RW	No	○	0 to 255 [Initial value: 140 (TLC)]	C

■ Input signals list

To assign signals via EtherCAT, use the "Assignment number" in the table instead of the signal name.

Assignment number	Signal name	Status
0	No function	–
1	FREE	0: No motion 1: Electromagnetic brake is in a state of releasing and motor non-excitation
3	CLR	0: No motion 1: Clear deviation
5	STOP	0: No motion 1: Stop operation
8	ALM-RST	0: No motion 1: Reset alarm
9	P-PRESET	0: No motion 1: Execute preset
12	ETO-CLR	0: No motion 1: Transition to a state possible to excite
13	LAT-CLR	0: No motion 1: Clear cumulative load
14	INFO-CLR	0: No motion 1: Clear information status
16	HMI	0: Function limitation 1: Release the function limitation
22	TRQ-LMT	0: Release the torque limiting 1: Torque limiting
23	SPD-LMT	0: Release the speed limit 1: Speed limit
26	FW-BLK	0: No motion 1: Stop the forward direction operation
27	RV-BLK	0: No motion 1: Stop the reverse direction operation
28	FW-LS	0: OFF 1: ON
29	RV-LS	
30	HOMES	
31	SLIT	
80	R0	
81	R1	
82	R2	
83	R3	
84	R4	
85	R5	
86	R6	
87	R7	
88	R8	
89	R9	
90	R10	
91	R11	
92	R12	
93	R13	
94	R14	
95	R15	
104	EXT1	

Assignment number	Signal name	Status
105	EXT2	0: OFF 1: ON



- When the same input signal is assigned to multiple input terminals, the function will be executed if any of the terminals becomes active.
- When the HMI input is not assigned to the input terminal, this input will always be 1. When it is assigned to both direct I/O (DIN0 to DIN5) and remote I/O (R-IN0 to R-IN15), the function will be executed when both of them changes to 1.

■ Output signals list

To assign signals via EtherCAT, use the "Assignment number" in the table instead of the signal name.

Assignment number	Signal name	Status
0	No function	–
1 to 127	Response signal (Input signal_R)	0: Input signal is OFF 1: Input signal is ON
128	CONST-OFF	0: OFF
129	ALM-A	0: No alarm 1: During alarm generation
130	ALM-B	0: During alarm generation 1: No alarm
131	SYS-RDY	0: During system preparation 1: System preparation is completed
132	READY	0: Operation not possible 1: Ready for operation
134	MOVE	0: Motor standstill 1: During motor operation
135	INFO	0: No information 1: During information generation
136	SYS-BSY	0: No internal processing 1: During internal processing
137	ETO-MON	0: Excitation possible 1: Excitation not possible
138	IN-POS	0: During positioning operation 1: Positioning operation is completed
139	ZV	0: Speed 0 is not reached 1: Speed 0 is reached
140	TLC	0: Within torque range 1: Outside torque range
141	VA	0: Target speed is not reached 1: Target speed is reached
142	SON-MON	0: Motor non-excitation 1: Motor excitation
144	HOME-END	0: Other than home 1: Home
145	ABSPEN	0: Coordinates setting is not completed 1: Coordinates setting is completed
149	PRST-DIS	0: Normal state 1: Preset is not completed
150	PRST-STLD	0: Mechanical home setting is not completed 1: Mechanical home setting is completed
151	ORGN-STLD	0: Mechanical home setting is not completed 1: Mechanical home setting is completed
152	RND-OVF	0 and 1 are switched every time the wrap range is exceeded.

Assignment number	Signal name	Status
153	FW-SLS	0: Software limit in the forward direction is not reached. 1: Software limit in the forward direction is reached.
154	RV-SLS	0: Software limit in the reverse direction is not reached. 1: Software limit in the reverse direction is reached.
155	ZSG	0: Normal state 1: Motor one revolution
156	RND-ZERO	0: Other than wrap home 1: Wrap home
160	AREA0	0: Outside the range of AREA 1: Inside the range of AREA
161	AREA1	
162	AREA2	
163	AREA3	
164	AREA4	
165	AREA5	
166	AREA6	
167	AREA7	
168	MPS	0: Main power supply OFF 1: Main power supply ON
169	MBC	0: Electromagnetic brake is in a state of holding 1: Electromagnetic brake is in a state of releasing
170	RG	0: Normal state 1: Regeneration state
172	EDM-MON	0: OFF 1: ON
173	HWTOIN-MON	
180	USR-OUT0	
181	USR-OUT1	
192	TRQ-LMTD	0: No torque limiting 1: Torque limiting
193	SPD-LMTD	0: No speed limit 1: Speed limit
196	OPE-BSY	0: No internal oscillation 1: During internal oscillation
204	DCMD-RDY	0: Operation not possible 1: Ready for operation
205	DCMD-FULL	0: No data in buffer 1: Data in buffer
206	OL-DTCT	0: Overload alarm detection torque is not reached 1: Overload alarm detection torque is reached
224	INFO-USRIO	0: No information 1: During information generation
225	INFO-POSERR	
226	INFO-DRVTMP	
227	INFO-MTRTMP	
228	INFO-OVOLT	
229	INFO-UVOLT	
230	INFO-TLCTIME	
231	INFO-LOAD	
232	INFO-SPD	
233	INFO-START	
234	INFO-ZHOME	
235	INFO-PR-REQ	
237	INFO-EGR-E	

Assignment number	Signal name	Status
238	INFO-RND-E	0: No information 1: During information generation
240	INFO-FW-OT	
241	INFO-RV-OT	
242	INFO-CULD0	
243	INFO-CULD1	
244	INFO-TRIP	
245	INFO-ODO	
247	INFO-TRQ	
248	INFO-STLTIME	
252	INFO-DSLMTD	
253	INFO-IOTEST	
254	INFO-CFG	
255	INFO-RBT	

5 Coordinates management

5-1 Overview of coordinates management

The **AZX** Series manages the position coordinates of the motor with the ABZO sensor (mechanical multi-rotation absolute encoder). The present coordinates are mechanically recorded inside the ABZO sensor. Therefore, even if the output shaft is rotated by an external force when the control power supply is in an OFF state, the absolute coordinates with respect to the home can be maintained.

Set the coordinates according to the following flow.

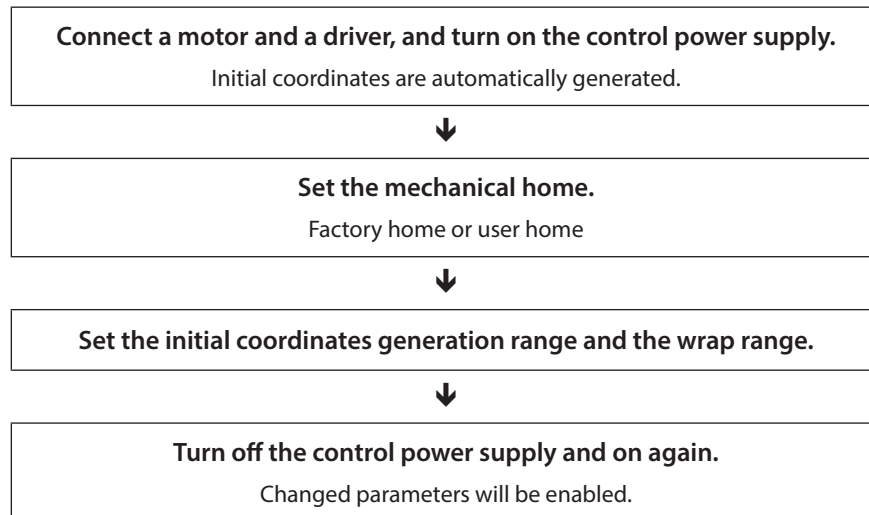

■ About ABZO sensor

The ABZO sensor is a mechanical multi-rotation absolute encoder that does not require a battery.

It stores the present position as an absolute position until the number of revolutions of the motor output shaft exceeds 1,800. The present position is stored even if the control power supply is turned off.

When the number of revolutions exceeds 1,800, the count number is reset to 0 and is newly started from 1.

■ Initial coordinate generation

"Initial coordinate generation" indicates to decide how to use the rotation range of up to 1,800 revolutions that the ABZO sensor can manage. There are four parameters required for initial coordinate generation as shown below. These parameters are read when the control power supply is turned on.

- Initial coordinate generation & wrap coordinate setting (47F2h)
- Initial coordinate generation & wrap setting range (41C9h)
- Initial coordinate generation & wrap range offset ratio (41CBh)
- Initial coordinate generation & wrap range offset value (41CCh)



Regardless of whether the wrap function is enabled or disabled, the initial coordinate is generated when the control power supply is turned on.

● Example of factory setting of the motor

To use coordinates both in forward and reverse directions, 1,800 revolutions are divided into positive and negative revolutions, 50 % for each direction.

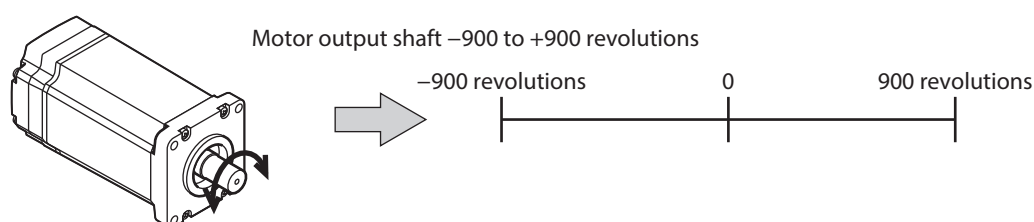

● **Setting example of motorized actuator**

The following is an example to set the home of a motorized actuator at the position of 30 mm from the motor side.

- Motorized actuator stroke: 600 mm
- Motorized actuator pitch: 6 mm/rev

Concept of initial coordinate

$$\text{Initial coordinate generation range} = \frac{\text{Stroke}}{\text{pitch}} = \frac{600}{6} = 100 \text{ revolutions}$$

$$\text{Wrap range offset ratio} = \frac{\text{Home position}}{\text{Stroke}} \times 100 = \frac{30}{600} \times 100 = 5 (\%)$$

From the above, the actual coordinate is in the range of -5 to 95 revolutions.

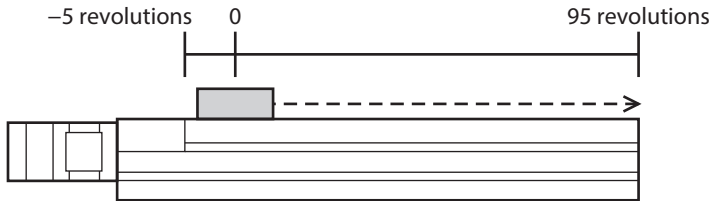

Setting examples of parameters

Index	Name	Setting value
47F2h	Initial coordinate generation & wrap coordinate setting	1: Manual setting
41C9h	Initial coordinate generation & wrap setting range [1=0.1 rev]	1,000
41CBh	Initial coordinate generation & wrap range offset ratio [1=0.01 %]	500
41CCh	Initial coordinate generation & wrap range offset value	0 step

■ **Wrap function**

The wrap function is a function to automatically preset the position information of the present position when the number of revolutions of the motor output shaft exceeds the set range. Setting the wrap offset can restrict the operation area of equipment or control an index table with coordinates on the positive and negative sides. Refer to p.125 for the specific setting methods.

memo The wrap function is enabled at the time of shipment. Disable the wrap function when it is not used. Set the parameters as follows.
 Initial coordinate generation & wrap coordinate setting (47F2h): 1 (Manual setting)
 Wrap (RND) setting (41C7h): 0 (Disable)

● **Concept of wrap setting**

With the wrap setting, 1,800 revolutions managed by the ABZO sensor are divided evenly to generate coordinates within the number of revolutions divided evenly.

Therefore, set a value that becomes an integer when 1,800 is divided.

Example:

If the wrap function is activated when the motor rotates by 180 revolutions in the same direction.

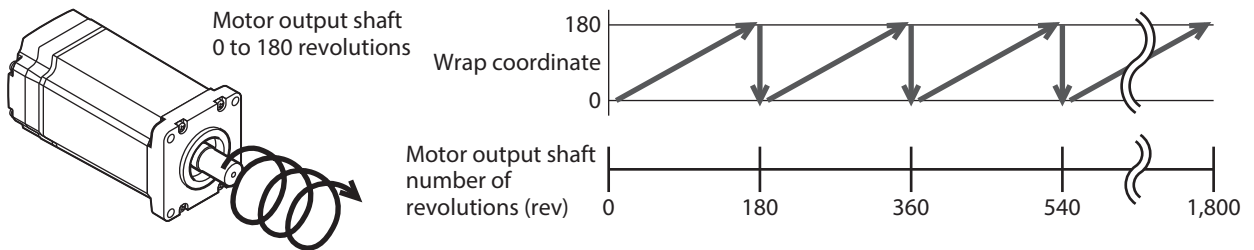

The present position of the motor is preset every 180 revolutions, however, the 32-bit counter in the driver is not preset.

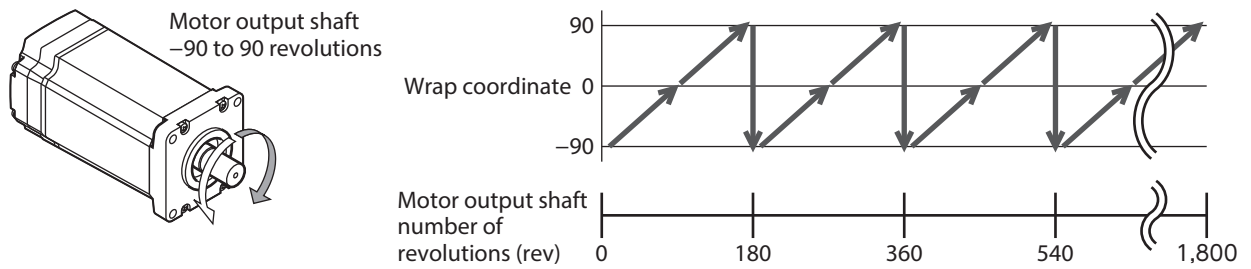
Example: When the range of use of the motor is offset to -90 to 90 revolutions

When the wrap setting range is exceeded, the sign is reversed.

- **Setting example of index table**

This is an example in which the index table is rotated once when the motor output shaft rotates 18 times.

- Gear ratio of motor: 18

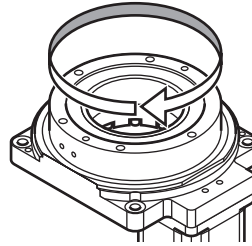
**Concept of initial coordinate**

To rotate the index table in both directions, 18 revolutions are divided into positive and negative revolutions, 50 % for each direction.

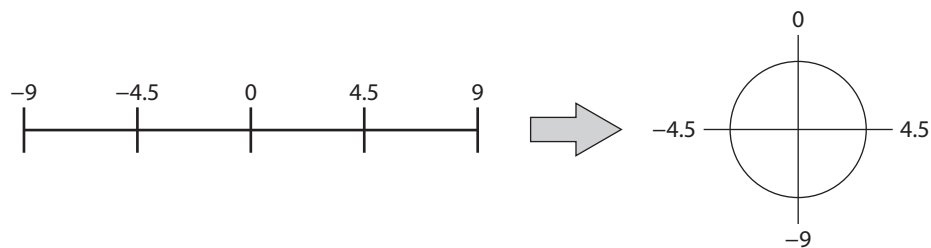
**Setting examples of parameters**

Index	Name	Setting value
47F2h	Initial coordinate generation & wrap coordinate setting	1: Manual setting
41C7h	Wrap (RND) setting	1: Enable
41C9h	Initial coordinate generation & wrap setting range [1=0.1 rev]	180
41CBh	Initial coordinate generation & wrap range offset ratio [1=0.01 %]	5,000
41CCh	Initial coordinate generation & wrap range offset value	0 step

● **Relation between the wrap function and the 32-bit counter inside the driver**

The 32-bit counter inside the driver outputs the position information of the motor as the number of steps regardless of whether the wrap function is enabled or disabled. When the wrap function is enabled, the relation between the wrap coordinate and the 32-bit counter is shown below.

Example:

If the wrap function is activated when the motor rotates by 180 revolutions in the same direction.

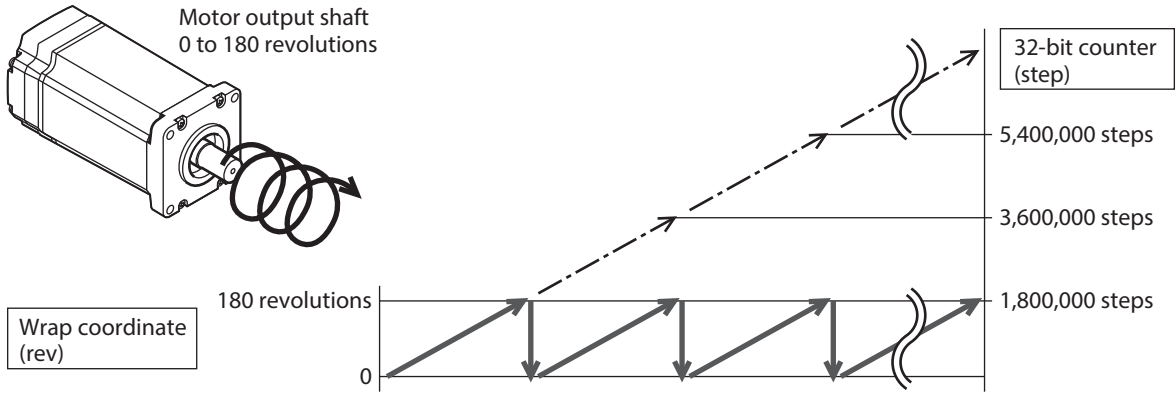

The present position of the motor is preset by 180 revolutions, however, the 32-bit counter is not preset. The value of the 32-bit counter can be checked by the Command position 32-bit counter (4091h). The 32-bit counter goes around between $-2,147,483,648$ and $2,147,483,647$.

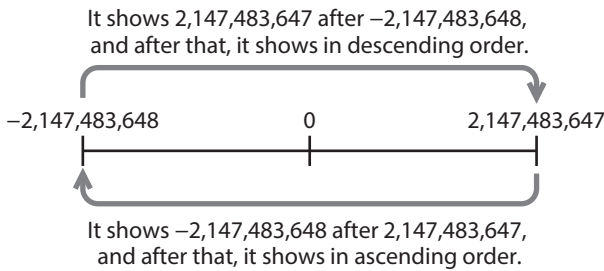

5-2 Coordinate origin

When coordinates are set, the ABSPEN output is turned ON.

Note

- The following operations cannot be executed if coordinates are not set.
- High-speed return-to-home operation
 - Absolute positioning operation (When the Permission of absolute positioning without setting absolute coordinates (4148h) is "0: Disable")

Related object

Index	Name	Description	Setting range	Initial value
4148h	Permission of absolute positioning without setting absolute coordinates	Permits absolute positioning operation in a state where coordinates are not set.	0: Disable 1: Enable	0

■ **Mechanical home**

The mechanical home is a position of the home stored by the ABZO sensor. The mechanical home includes the "factory home" written in the ABZO sensor at the time of factory shipment and the "User home" set by performing return-to-home operation or the position preset (P-PRESET).

● **Factory home**

The factory home is set in products with which the mechanism is pre-assembled to the motor, such as motorized actuators. It cannot be changed. If the factory home is set, the ORGN-STLD output is turned ON.

● User home

When the user home is set by performing return-to-home operation or the position preset (P-PRESET), the PRST-STLD output is turned ON. The user home can be cleared by the "Position preset clear" of the **MEXE02**.

If the user home is set, the home information is written to the non-volatile memory. The non-volatile memory can be rewritten approximately 100,000 times.

■ Mechanical home setting

To set the mechanical home coordinates, perform the position preset (P-PRESET) or return-to-home operation. If the mechanical home coordinates are set, operation is performed on the coordinates centered on the mechanical home.

● Position preset (P-PRESET)

If the position preset (P-PRESET) is executed, the command position and the feedback position changes to the value set in the Home offset (607Ch) and the home is set.

Related objects

Index	Name	Description	Setting range	Initial value
607Ch	Home offset	Sets the preset position.	-2,147,483,648 to 2,147,483,647 steps	0
4148h	Permission of absolute positioning without setting absolute coordinates	Permits absolute positioning operation in a state where coordinates are not set.	0: Disable 1: Enable	0

● Return-to-home operation

When return-to-home operation is performed, the mechanical home can be set.

■ A state where coordinates setting is not completed

Coordinates will be an unset state in the following cases. The ABSPEN output is turned OFF.

- Factory shipment state
- When the position preset (P-PRESET) is performed in a state where the Home offset (607Ch) is set to a value other than "0" and then the resolution is changed
- When [Position preset clear] under the [Communication] menu of the **MEXE02** software is executed.
- During return-to-home operation

5-3 Parameters related to ABZO sensor

With the **AZX** Series, the specifications of the ABZO sensor and parameters based on the pre-assembled mechanism to the motor are written in the ABZO sensor in advance.

Related objects

Index	Name	Description	Setting range	Initial value
47F0h	Mechanism settings	To change the mechanism settings parameter, select "Manual setting."	0: Prioritize ABZO setting 1: Manual setting	1
47F1h	Gear ratio setting	Sets the gear ratio for geared motor. When "0: Gear ratio setting disable" is set, the gear ratio is considered as "1."	0: Gear ratio setting disable 1 to 32,767: Gear ratio (1=0.01)	0
47F2h	Initial coordinate generation & wrap coordinate setting	To change the initial coordinate generation & wrap coordinate parameter, select "Manual setting."	0: Prioritize ABZO setting 1: Manual setting	0
47F3h	Mechanism limit parameter setting	Disables the ABZO setting of the mechanism limit parameter.	0: Follow ABZO setting 1: Disable	0
47F4h	Mechanism protection parameter setting	Disables the ABZO setting of the mechanism protection parameter.	0: Follow ABZO setting 1: Disable	0
47F5h	JOG/HOME/ZHOME operation setting	To change the parameter for JOG operation and return-to-home operation, select "Manual setting."	0: Prioritize ABZO setting 1: Manual setting	0

■ When parameters of the wrap function are set

● Setting example: When the wrap range is set to –50 to 50 revolutions

1. Change the Initial coordinate generation & wrap coordinate setting (47F2h) to "1: Manual setting." When it is changed to "1: Manual setting" the following driver parameters can be set manually.
 - Wrap (RND) setting
 - The number of the RND-ZERO output in wrap range
 - Initial coordinate generation & wrap setting range
 - Initial coordinate generation & wrap range offset ratio
 - Initial coordinate generation & wrap range offset value
2. Set each parameter as follows.

Index	Name	Setting value
41C7h	Wrap (RND) setting	1: Enable
41CDh	The number of the RND-ZERO output in wrap range	1
41C9h	Initial coordinate generation & wrap setting range [1=0.1 rev]	1,000
41CBh	Initial coordinate generation & wrap range offset ratio [1=0.01 %]	5,000
41CCh	Initial coordinate generation & wrap range offset value	0 step

5-4 Mechanism settings parameter

The mechanism settings parameter is a parameter required when used in combination with a mechanism, such as geared motors or motorized actuators.



Note To change the mechanism settings parameter, change the Mechanism settings (47F0h) to "1: Manual setting" [Initial value: 1 (Manual setting)]. When this parameter is changed, turn off the control power supply of the driver and on again.

■ Motor rotation direction

Set the relation between the coordinate system of the motor and the actual rotation direction.

Related object

Index	Name	Description	Setting range	Initial value
41C2h	Motor rotation direction	Sets the rotation direction of the motor output shaft.	0: Positive side=Counterclockwise 1: Positive side=Clockwise 2: Positive side=Counterclockwise (the driver parameter is applied) 3: Positive side=Clockwise (the driver parameter is applied)	1

5-5 Initial coordinate generation & wrap coordinate parameters

These are parameters to be used when the coordinate system is generated.

■ Wrap function

Refer to p.120 for the wrap function.

● Related operation types

When the following operations are performed in the Profile position mode (PP), set the wrap function.

- Wrap absolute positioning operation
- Wrap proximity positioning operation
- Wrap forward direction absolute positioning operation
- Wrap reverse direction absolute positioning operation

Related objects

Index	Name	Description	Setting range	Initial value
414Fh	Wrap positioning mode	Sets the operation type for wrap positioning operation.	0: Wrap absolute positioning 1: Wrap proximity 2: Wrap forward direction 3: Wrap reverse direction	0
47F2h	Initial coordinate generation & wrap coordinate setting	To use the wrap function, select "Manual setting."	0: Prioritize ABZO setting 1: Manual setting	0
41C7h	Wrap (RND) setting	Sets the wrap function.	0: Disable 1: Enable	1
41C9h	Initial coordinate generation & wrap setting range	Sets the wrap range. The command position returns to 0 when the motor rotates by the number of times set here.	Refer to the next table. (1=0.1 rev)	10
41CBh	Initial coordinate generation & wrap range offset ratio	Sets the offset ratio of the wrap range.	0 to 10,000 (1=0.01 %)	5,000
41CCh	Initial coordinate generation & wrap range offset value	Sets the offset amount of the wrap range.	-536,870,912 to 536,870,911 steps	0

Value that can be set in the Initial coordinate generation & wrap setting range (41C9h)

Since the internal coordinate of the ABZO sensor is 1,800 revolutions, select a value from the table to set in the Initial coordinate generation & wrap setting range (41C9h).

 The table shows the values when setting with the **MEXE02** software. When setting via EtherCAT, multiply the values in the table by 10.

Wrap setting range [rev]						
0.5	1.8	4.8	12.0	25.0	72.0	200.0
0.6	2.0	5.0	12.5	30.0	75.0	225.0
0.8	2.4	6.0	14.4	36.0	90.0	300.0
0.9	2.5	7.2	15.0	37.5	100.0	360.0
1.0	3.0	7.5	18.0	40.0	112.5	450.0
1.2	3.6	8.0	20.0	45.0	120.0	600.0
1.5	4.0	9.0	22.5	50.0	150.0	900.0
1.6	4.5	10.0	24.0	60.0	180.0	1,800.0

● **Setting example**

When setting the Initial coordinate generation & wrap range offset ratio (41CBh) to "50 %" and the Initial coordinate generation & wrap range offset value (41CCh) to "0 step"

Example 1: Coordinates when the wrap setting range is 1 revolution and the resolution is 10,000 P/R

Index	Sub	Name	Setting value
6091h	01h	Electronic gear A	1
	02h	Electronic gear B	1
47F2h	00h	Initial coordinate generation & wrap coordinate setting	1: Manual setting
41C7h	00h	Wrap (RND) setting	1: Enable
41C9h	00h	Initial coordinate generation & wrap setting range [1=0.1 rev]	10
41CBh	00h	Initial coordinate generation & wrap range offset ratio [1=0.01 %]	5,000
41CCh	00h	Initial coordinate generation & wrap range offset value	0 step

Coordinates example

When the parameters are set as shown in the above table, the motor can be operated on coordinates in the figure.

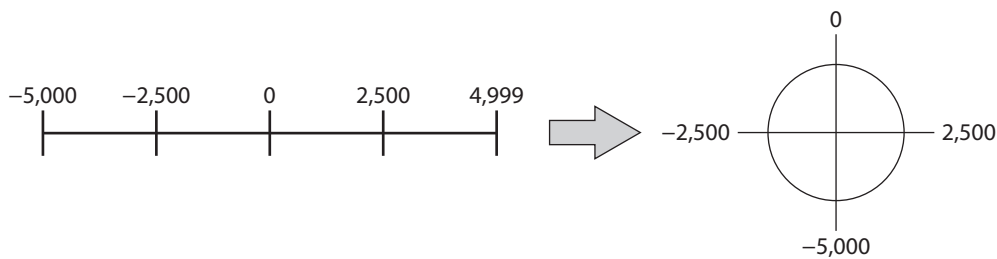

Example 2: Coordinates when the wrap setting range is 1,800 revolutions and the resolution is 10,000 P/R

Index	Sub	Name	Setting value
6091h	01h	Electronic gear A	1
	02h	Electronic gear B	1
47F2h	00h	Initial coordinate generation & wrap coordinate setting	1: Manual setting
41C7h	00h	Wrap (RND) setting	1: Enable
41C9h	00h	Initial coordinate generation & wrap setting range [1=0.1 rev]	18,000
41CBh	00h	Initial coordinate generation & wrap range offset ratio [1=0.01 %]	5,000
41CCh	00h	Initial coordinate generation & wrap range offset value	0 step

Coordinates example

When the parameters are set as shown in the above table, the motor can be operated on coordinates in the figure.

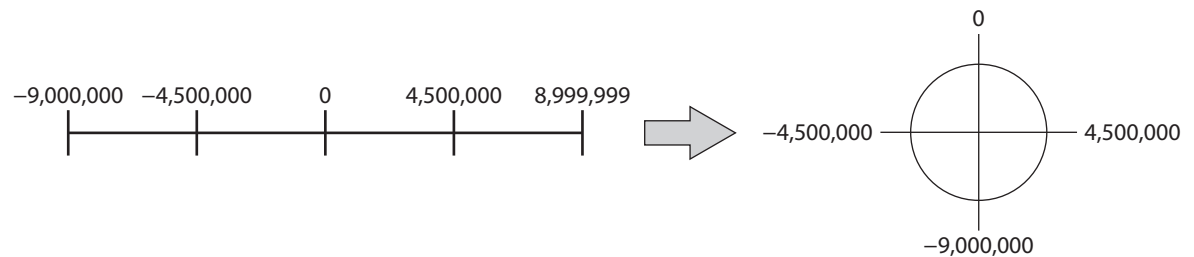

Note If the Wrap (RND) setting (41C7h) or the Initial coordinate generation & wrap setting range (41C9h) is changed, the absolute position may be shifted. When the parameter is changed, perform the position preset (P-PRESET) or return-to-home operation.

● Setting conditions of Initial coordinate generation & wrap setting range (41C9h)

When the wrap range satisfies the following conditions, continuous rotation in the same direction can be performed while the home is maintained.

$$\text{Condition 1) } \frac{1,800}{\text{Wrap setting range}} = \text{To be an integer}$$

$$\text{Condition 2) } \text{Wrap setting range} \times \text{Resolution} = \text{Wrap setting range} \times \frac{\text{Electronic gear B}}{\text{Electronic gear A}} \times 10,000 = \text{To be an integer}$$



If the setting conditions of the Initial coordinate generation & wrap setting range (41C9h) is not satisfied even when the Wrap (RND) setting (41C7h) is set to "1: Enable," information of the Wrap setting error will be generated. If the control power supply is turned on again or Configuration is executed in a state where information of Wrap setting error is generated, an alarm of Wrap setting error will be generated.

Setting example 1

- Wrap setting range: 100 revolutions
- Resolution: 10,000 P/R (Electronic gear A: 1, electronic gear B: 1)
- Motor: Standard motor (Gear ratio 1)

$$\text{Condition 1) } \frac{1,800}{\text{Wrap setting range}} = \frac{1,800}{100} = 18$$

$$\text{Condition 2) } \text{Wrap setting range} \times \frac{\text{Electronic gear B}}{\text{Electronic gear A}} \times 10,000 = 100 \times \frac{1}{1} \times 10,000 = 1,000,000$$

The setting conditions are satisfied since both the conditions (1) and (2) are integers. The wrap function can be used.

Setting example 2

- Wrap setting range: 4.5 revolutions
- Resolution: 10,000 P/R (Electronic gear A: 1, electronic gear B: 1)
- Actuator: **DGII** Series (Gear ratio 18)

$$\text{Condition 1) } \frac{1,800}{\text{Wrap setting range}} = \frac{1,800}{4.5} = 400$$

$$\text{Condition 2) } \text{Wrap setting range} \times \frac{\text{Electronic gear B}}{\text{Electronic gear A}} \times 10,000 = 4.5 \times \frac{1}{1} \times 10,000 = 45,000$$

The setting conditions are satisfied since both the conditions (1) and (2) are integers. In this setting, the wrap function is executed every time the output table of the **DGII** Series rotates by 90 degrees.

Setting example 3

- Wrap setting range: 1,000 revolutions
- Resolution: 10,000 P/R (Electronic gear A: 1, electronic gear B: 1)
- Motor: **PS** geared motor (Gear ratio 20)

$$\text{Condition 1) } \frac{1,800}{\text{Wrap setting range}} = \frac{1,800}{1,000} = 1.8$$

$$\text{Condition 2) } \text{Wrap setting range} \times \text{Resolution} = 1,000 \times 10,000 = 10,000,000$$

The setting conditions are not satisfied since the condition (1) is not an integer. Information of Wrap setting error is generated and the wrap function cannot be executed.

■ **Wrap offset function**

The position of the boundary point of the wrap range can be offset by using the mechanical home as a reference. The wrap offset is set with the Initial coordinate generation & wrap range offset ratio (41CBh) and the Initial coordinate generation & wrap range offset value (41CCh).

● **Wrap offset ratio setting**

When the Initial coordinate generation & wrap range offset ratio (41CBh) is set, the wrap range can be offset in the negative direction.

Setting example: When the wrap range is 1,800 revolutions and the resolution is 10,000 P/R

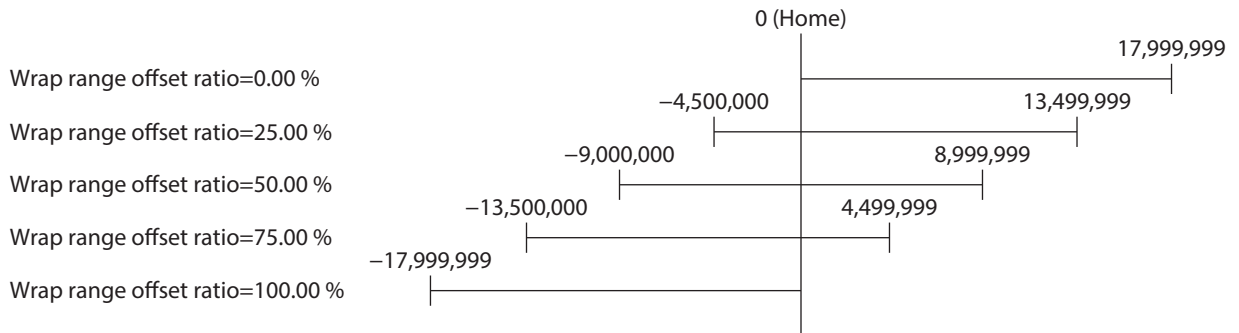

● **Wrap range offset value setting**

The coordinates can be shifted in a step unit for the coordinate system having offset with the Initial coordinate generation & wrap range offset ratio (41CBh).

Note When the coordinates are set with the Initial coordinate generation & wrap range offset value (41CCh), information of Wrap setting error is generated if the home is not included in the coordinates. If the control power supply is turned on again or Configuration is executed in a state where information of Wrap setting error is generated, an alarm of Wrap setting error will be generated.

Setting example 1:

When the wrap range is 1,800 revolutions, the resolution is 10,000 P/R, and the wrap offset ratio setting is 50 %.

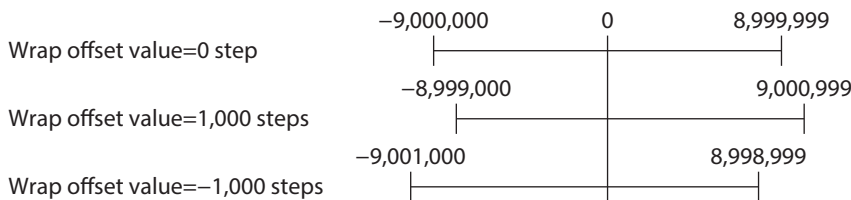

Setting example 2:

When the wrap range is 1,800 revolutions, the resolution is 10,000 P/R, and the wrap offset ratio setting is 0 %.

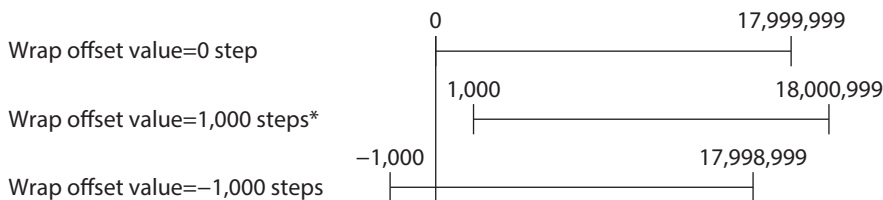

* Information of wrap setting error is generated

■ RND-ZERO output

The RND-ZERO output is a signal that is output for each division boundary point when the wrap range is divided evenly with the home as a reference.

The number of divisions can be set with the The number of the RND-ZERO output in wrap range (41CDh). The RND-ZERO output is output when the Wrap (RND) setting (41C7h) is set to "1: Enable."

● Example of use 1

**When the RND-ZERO signal is output for every rotation of the output shaft
(When the wrap range is 1,800 revolutions and the gear ratio of a geared motor is 5)**

$$\text{The number of the RND-ZERO output in wrap range} = \frac{\text{Wrap setting range}}{\text{Gear ratio}} = \frac{1,800}{5} = 360$$

This example of use can check that the position of the motor is in the home. With a geared motor, it can be used as a phase Z signal that outputs one pulse for every rotation.

● Example of use 2

When the moving range is evenly divided by 90 degrees and the RND-ZERO signal is output for a certain travel amount

$$\text{Number of divisions of movable range} = \frac{360^\circ}{90^\circ} = 4$$

$$\text{The number of the RND-ZERO output in wrap range} = \frac{\text{Wrap setting range}}{\text{Gear ratio}} \times \text{Number of divisions of movable range} = \frac{1,800}{18} \times 4 = 400$$

This example of use can output a signal regularly during operation of the motorized actuator or hollow rotary actuator. It can be used to synchronize multiple motors and to operate by inputting the RND-ZERO signal to other system.

Related object

Index	Name	Description	Setting range	Initial value
41CDh	The number of the RND-ZERO output in wrap range	Sets the number of times to turn the RND-ZERO output ON in the wrap range.	1 to 536,870,911 divisions	1

5-6 Mechanism limit

Depending on the motorized actuator, the mechanism limit (mechanical end) has been stored in the ABZO sensor at the time of shipment. (Fixed value)

If a product having set the home reached the mechanism limit stored in the ABZO sensor, an alarm of Mechanical overtravel will be generated.

The details of the ABZO information (fixed value) can be checked using the unit information monitor of the **MEXE02** software.

The ABZO information (fixed value) is normally used, but if it is necessary to disable the value, change the Mechanism limit parameter setting (47F3h) to "1: Disable."

Related object

Index	Name	Description	Setting range	Initial value
47F3h	Mechanism limit parameter setting	Disables the ABZO setting of the mechanism limit parameter.	0: Follow ABZO setting 1: Disable	0



Note If the Mechanism limit parameter setting (47F3h) is changed to "1: Disable," the alarm function using the ABZO information (fixed value) is also disabled.

5-7 Mechanism protection

In the case of a motorized actuator, the maximum values for the starting speed and operating speed are stored in the ABZO sensor at the time of shipment. (Fixed value)

If the motor is operated beyond the fixed value of the ABZO sensor, an alarm of Operation data error will be generated.

The details of the ABZO information (fixed value) can be checked using the unit information monitor of the **MEXE02** software.

The ABZO information (fixed value) is normally used, but if it is necessary to disable the value, change the Mechanism protection parameter setting (47F4h) to "1: Disable."

Related object

Index	Name	Description	Setting range	Initial value
47F4h	Mechanism protection parameter setting	Disables the ABZO setting of the mechanism protection parameter.	0: Follow ABZO setting 1: Disable	0



Note If the Mechanism protection parameter setting (47F4h) is changed to "1: Disable," the alarm function using the ABZO information (fixed value) is also disabled.

6 Torque limiting function

The maximum output torque of the motor can be limited. Sets when limiting the output torque of the motor according to a load.

When the TRQ-LMT input is turned ON, the torque limiting function is enabled.

Related object

Index	Name	Description	Setting range	Initial value
6072h	Maximum torque	Sets the torque limiting value for the operation data.	0 to 10,000 (1=0.1 %)	1,000

7 Saving parameters

Parameters are saved in the RAM or non-volatile memory of the driver. The parameters in the RAM are erased once the control power supply is shut off, but the parameters in the non-volatile memory are remained to store even if the control power supply is shut off. When the control power supply of the driver is turned on, the parameters stored in the non-volatile memory are transferred to the RAM, and recalculation and setup for the parameters are executed in the RAM.

When parameters are set via EtherCAT, they are stored in the RAM. To save the parameters stored in the RAM to the non-volatile memory, execute the Write batch NV memory (40C9h) of the maintenance command.

Note Do not shut off the control power supply while writing the data to the non-volatile memory, and also do not shut off for 5 seconds after the completion of writing the data. Doing so may abort the data write and cause an alarm of EEPROM error (alarm code 41h) to generate.

memo The non-volatile memory can be rewritten approximately 100,000 times.

■ How to execute the maintenance commands

The following two methods are available to execute maintenance commands. Use them selectively in accordance with the intended use.

● Write 1 to data (Recommended)

When data is changed from 0 to 1 after 1 is written to it, the command is executed.

To execute the same command again, restore the data to 0 and then write 1. It is safe because the command is not executed in succession even if 1 is consecutively written from the EtherCAT MainDevice.

● Write 2 to data

When 2 is written to data, the command is executed. After execution, the data is restored to 1 automatically. Data does not need to restore to 1, and it can be written consecutively.

If commands which take time to write to the non-volatile memory such as Write batch NV memory (40C9h) are executed consecutively, increase the length of the intervals between commands.

5 Object list

This part describes the lists of objects supported by the driver.

◆ Table of contents

1	Composition of object dictionary	134
2	Objects of CoE communication area.....	135
	2-1 Descriptions of each object	135
	2-2 Object list.....	139
3	Objects of profile area	142
	3-1 Descriptions of each object	142
	3-2 Object list.....	151
4	Objects of manufacturer-specific area.....	154
	4-1 Descriptions of each object	154
	4-2 Object list.....	182



1 Composition of object dictionary

Objects are composed as follows.

Index (Hex)	Object	Overview
1000h to 1FFFh	CoE Communication Area	CoE communication area
2000h to 3FFFh	Manufacturer-Specific Area	No function
4000h to 4FFFh		Driver object
5000h to 5FFFh		No function
6000h to 67FFh	Profile Area	Profile area

■ How to read the table

● Object dictionary names (Index)

Item	Description																																				
Index	Index of objects.																																				
Sub	Sub-index of objects.																																				
Name	Indicates the name of each sub-index when there are multiple sub-indexes.																																				
Type	<p>Definition objects of data type. Abbreviations described in the table below are used in this manual.</p> <table border="1"> <thead> <tr> <th>Abbreviation</th> <th>Data type</th> <th>Description</th> <th>Range of value</th> </tr> </thead> <tbody> <tr> <td>BOOL</td> <td>Boolean</td> <td>1-bit unsigned data</td> <td>0, 1</td> </tr> <tr> <td>INT8</td> <td>Integer8</td> <td>8-bit signed data</td> <td>-128 to 127</td> </tr> <tr> <td>INT16</td> <td>Integer16</td> <td>16-bit signed data</td> <td>-32,768 to 32,767</td> </tr> <tr> <td>INT32</td> <td>Integer32</td> <td>32-bit signed data</td> <td>-2,147,483,648 to 2,147,483,647</td> </tr> <tr> <td>U8</td> <td>Unsigned8</td> <td>8-bit unsigned data</td> <td>0 to 255</td> </tr> <tr> <td>U16</td> <td>Unsigned16</td> <td>16-bit unsigned data</td> <td>0 to 65,535</td> </tr> <tr> <td>U32</td> <td>Unsigned32</td> <td>32-bit unsigned data</td> <td>0 to 4,294,967,295</td> </tr> <tr> <td>STRING</td> <td>Visible String</td> <td>Character string</td> <td>-</td> </tr> </tbody> </table>	Abbreviation	Data type	Description	Range of value	BOOL	Boolean	1-bit unsigned data	0, 1	INT8	Integer8	8-bit signed data	-128 to 127	INT16	Integer16	16-bit signed data	-32,768 to 32,767	INT32	Integer32	32-bit signed data	-2,147,483,648 to 2,147,483,647	U8	Unsigned8	8-bit unsigned data	0 to 255	U16	Unsigned16	16-bit unsigned data	0 to 65,535	U32	Unsigned32	32-bit unsigned data	0 to 4,294,967,295	STRING	Visible String	Character string	-
Abbreviation	Data type	Description	Range of value																																		
BOOL	Boolean	1-bit unsigned data	0, 1																																		
INT8	Integer8	8-bit signed data	-128 to 127																																		
INT16	Integer16	16-bit signed data	-32,768 to 32,767																																		
INT32	Integer32	32-bit signed data	-2,147,483,648 to 2,147,483,647																																		
U8	Unsigned8	8-bit unsigned data	0 to 255																																		
U16	Unsigned16	16-bit unsigned data	0 to 65,535																																		
U32	Unsigned32	32-bit unsigned data	0 to 4,294,967,295																																		
STRING	Visible String	Character string	-																																		
Access	<p>Access method of objects.</p> <ul style="list-style-type: none"> • RW: Read and write of values are possible. • RO: Only read of values is possible. 																																				
PDO	<p>Indicates whether PDO mapping of objects is possible.</p> <ul style="list-style-type: none"> • RxPDO: Mapping to RxPDO is possible. • TxPDO: Mapping to TxPDO is possible. • No: Mapping to PDO is not possible. 																																				
Save	<p>Indicates whether data is saved in the non-volatile memory when the Write batch NV memory was executed.</p> <ul style="list-style-type: none"> • O: Saved in the non-volatile memory. • -: Not saved in the non-volatile memory. 																																				
Initial value	Indicates the initial value.																																				
Range	Indicates the setting range.																																				
Update	<p>Indicates the timing for updating the change when a value in the object is changed.</p> <ul style="list-style-type: none"> • A: Update immediately • B: Update after operation stop • C: Update after executing configuration • D: Update after turning on the control power supply again 																																				

2 Objects of CoE communication area

These objects are used to make settings related to EtherCAT or to indicate the status.

2-1 Descriptions of each object

- **Device Type (1000h)**

This indicates the device profile.

Index	Sub	Type	Access	PDO	Save	Initial value	Range	Update
1000h	00h	U32	RO	No	–	0002 0192h	Bit 0 to Bit 15: Device profile (0192h: DS402) Bit 16 to Bit 31: Additional information (0002h: SV single axis driver)	–

- **Error register (1001h)**

This indicates the error status of the driver. If an error occurs in the driver, the General error (bit 0) is changed to 1. It is changed to 0 when the error is cleared.

Index	Sub	Type	Access	PDO	Save	Initial value	Range	Update
1001h	00h	U8	RO	No	–	0	–	–

- **Manufacturer Device Name (1008h)**

This indicates the product name.

Index	Sub	Type	Access	PDO	Save	Initial value	Range	Update
1008h	00h	STRING	RO	No	–	AZXD-SED	–	–

- **Manufacturer Hardware Version (1009h)**

This indicates the hardware version of the driver. "V.1.00" is indicated when the version is 1.00.

Index	Sub	Type	Access	PDO	Save	Initial value	Range	Update
1009h	00h	STRING	RO	No	–	Indicates the version number	–	–

- **Manufacturer Software Version (100Ah)**

This indicates the software version of the driver. "V.1.00" is indicated when the version is 1.00.

Index	Sub	Type	Access	PDO	Save	Initial value	Range	Update
100Ah	00h	STRING	RO	No	–	Indicates the version number	–	–

- **Identity Object (1018h)**

This indicates the product information of the driver. The serial number is always 0.

Index	Sub	Name	Type	Access	PDO	Save	Initial value	Range	Update
1018h	00h	Number of entries	U8	RO	No	–	4	–	–
	01h	Vendor ID	U32	RO	No	–	0000 02BEh	–	–
	02h	Product Code	U32	RO	No	–	0000 142Dh	–	–
	03h	Revision Number	U32	RO	No	–	0000 xxxh	–	–
	04h	Serial Number	U32	RO	No	–	0	–	–

● **Receive PDO mapping 1 (1600h)**

This is used to set the receive PDO mapping 1.

Index	Sub	Name	Type	Access	PDO	Save	Initial value	Range	Update
1600h	00h	Number of entries	U8	RW	No	–	3	0 to 16	A
	01h	Mapping entry 1	U32	RW	No	–	6040 0010h	0000 0000h to FFFF FFFFh	A
	02h	Mapping entry 2	U32	RW	No	–	607A 0020h		A
	03h	Mapping entry 3	U32	RW	No	–	6060 0008h		A
	04h to 10h	Mapping entry 4 to 16	U32	RW	No	–	0000 0000h		A

● **Receive PDO mapping 2 (1601h)**

This is used to set the receive PDO mapping 2.

Index	Sub	Name	Type	Access	PDO	Save	Initial value	Range	Update
1601h	00h	Number of entries	U8	RW	No	–	5	0 to 16	A
	01h	Mapping entry 1	U32	RW	No	–	6040 0010h	0000 0000h to FFFF FFFFh	A
	02h	Mapping entry 2	U32	RW	No	–	607A 0020h		A
	03h	Mapping entry 3	U32	RW	No	–	60FF 0020h		A
	04h	Mapping entry 4	U32	RW	No	–	6060 0008h		A
	05h	Mapping entry 5	U32	RW	No	–	60B8 0010h		A
	06h to 10h	Mapping entry 6 to 16	U32	RW	No	–	0000 0000h		A

● **Transmit PDO mapping 1 (1A00h)**

This is used to set the transmit PDO mapping 1.

Index	Sub	Name	Type	Access	PDO	Save	Initial value	Range	Update
1A00h	00h	Number of entries	U8	RW	No	–	3	0 to 16	A
	01h	Mapping entry 1	U32	RW	No	–	6041 0010h	0000 0000h to FFFF FFFFh	A
	02h	Mapping entry 2	U32	RW	No	–	6064 0020h		A
	03h	Mapping entry 3	U32	RW	No	–	6061 0008h		A
	04h to 10h	Mapping entry 4 to 16	U32	RW	No	–	0000 0000h		A

● **Transmit PDO mapping 2 (1A01h)**

This is used to set the transmit PDO mapping 2.

Index	Sub	Name	Type	Access	PDO	Save	Initial value	Range	Update
1A01h	00h	Number of entries	U8	RW	No	–	8	0 to 16	A
	01h	Mapping entry 1	U32	RW	No	–	6041 0010h	0000 0000h to FFFF FFFFh	A
	02h	Mapping entry 2	U32	RW	No	–	6064 0020h		A
	03h	Mapping entry 3	U32	RW	No	–	6061 0008h		A
	04h	Mapping entry 4	U32	RW	No	–	60B9 0010h		A
	05h	Mapping entry 5	U32	RW	No	–	60BA 0020h		A
	06h	Mapping entry 6	U32	RW	No	–	60BC 0020h		A
	07h	Mapping entry 7	U32	RW	No	–	603F 0010h		A
	08h	Mapping entry 8	U32	RW	No	–	60FD 0020h		A
	09h to 10h	Mapping entry 9 to 16	U32	RW	No	–	0000 0000h		A

- **Sync Manager communication (1C00h)**

This is used to set the communication type of Sync Manager (SM).

Index	Sub	Name	Type	Access	PDO	Save	Initial value	Range	Update
1C00h	00h	Number of entries	U8	RO	No	–	4	–	–
	01h	Communication type sync manager 0	U8	RO	No	–	1: Mailbox output (MainDevice to driver)	–	–
	02h	Communication type sync manager 1	U8	RO	No	–	2: Mailbox input (Driver to MainDevice)	–	–
	03h	Communication type sync manager 2	U8	RO	No	–	3: Process data output (MainDevice to driver)	–	–
	04h	Communication type sync manager 3	U8	RO	No	–	4: Process data input (Driver to MainDevice)	–	–

- **Sync Manager 2 PDO assignment (1C12h)**

This is used to set the object assigned in the Process data output (receive PDO: RxPDO) of the Sync manager 2 (SM2). It can be changed when the EtherCAT communication state machine is Pre-Operational.

Refer to p.67 for how to set the PDO mapping.

Index	Sub	Name	Type	Access	PDO	Save	Initial value	Range	Update
1C12h	00h	Number of entries	U8	RW	No	–	1	0 to 1	A
	01h	Index of assigned PDO 1	U16	RW	No	–	1600h	0000h to FFFFh	A

- **Sync Manager 3 PDO assignment (1C13h)**

This is used to set the object assigned in the Process data input (transmit PDO: TxPDO) of the Sync manager 3 (SM3). It can be changed when the EtherCAT communication state machine is Pre-Operational.

Refer to p.67 for how to set the PDO mapping.

Index	Sub	Name	Type	Access	PDO	Save	Initial value	Range	Update
1C13h	00h	Number of entries	U8	RW	No	–	1	0 to 1	A
	01h	Index of assigned PDO 1	U16	RW	No	–	1A00h	0000h to FFFFh	A

- **Sync Manager 2 Synchronization (1C32h)**

This is used to set the Synchronization Type of the Sync Manager 2 (SM2) and indicates the status.

Index	Sub	Name	Type	Access	PDO	Save	Initial value	Range	Update
1C32h	00h	Number of entries	U8	RO	No	–	20h	–	–
	01h	Synchronization Type	U16	RW	No	–	02h	00h to 02h	A
	02h	Cycle Time [ns]	U32	RO	No	–	–	–	–
	03h	Shift time [ns]	U32	RO	No	–	0	–	–
	04h	Synchronization Types supported	U16	RO	No	–	0007h	–	–
	05h	Minimum Cycle Time [ns]	U32	RO	No	–	0003 D090h (250,000 ns)	–	–
	06h	Calc and Copy Time [ns]	U32	RO	No	–	0001 86A0h (100,000 ns)	–	–
	07h	Reserved	U32	–	–	–	–	–	–
	08h	Reserved	U16	–	–	–	–	–	–
	09h	Delay Time [ns]	U32	RO	No	–	0	–	–
	0Ah to 1Fh	Reserved	U16	–	–	–	–	–	–
	20h	Sync Error	BOOL	RO	No	–	0	–	–

Details of Sync Manager 2 Synchronization objects

Sub	Name	Description
01h	Synchronization Type	00h: Free Run mode (asynchronous) 01h: Sync Manager 2 event synchronization mode 02h: DC mode (SYNC0 event synchronization)
02h	Cycle Time [ns]	Indicates the Cycle Time of the SYNC0 event.
03h	Shift Time [ns]	The Shift Time is not supported. The read value is always 0.
04h	Synchronization Types supported	Indicates the Synchronization Type supported. Bit0: Free Run mode (asynchronous) Bit1: Sync Manager 2 event synchronization mode Bit2: DC mode (SYNC0 event synchronization)
05h	Minimum Cycle Time [ns]	Indicates the Minimum Cycle Time supported.
06h	Calc and Copy Time [ns]	Indicates the minimum value of the internal calculation and copy time that is needed from the Sync Manager 2 event to the SYNC0 event.
09h	Delay Time [ns]	The Delay Time is not supported. The read value is always 0.
20h	Sync Error	Changes to 1 if the Sync Error is detected.

● Sync Manager 3 Synchronization (1C33h)

This is used to set the Synchronization Type of the Sync Manager 3 (SM3) and indicates the status.

Index	Sub	Name	Type	Access	PDO	Save	Initial value	Range	Update
1C33h	00h	Number of entries	U8	RO	No	–	20h	–	–
	01h	Synchronization Type	U16	RW	No	–	02h	00h, 02h, 22h	A
	02h	Cycle Time [ns]	U32	RO	No	–	–	–	–
	03h	Shift Time [ns]	U32	RO	No	–	0	–	–
	04h	Synchronization Types supported	U16	RO	No	–	0007h	–	–
	05h	Minimum Cycle Time [ns]	U32	RO	No	–	0003 D090h (250,000 ns)	–	–
	06h	Calc and Copy Time [ns]	U32	RO	No	–	0002 49F0h (150,000 ns)	–	–
	07h	Reserved	U32	–	–	–	–	–	–
	08h	Reserved	U16	–	–	–	–	–	–
	09h	Delay time [ns]	U32	RO	No	–	0	–	–
	0Ah to 1Fh	Reserved	U16	–	–	–	–	–	–
	20h	Sync Error	BOOL	RO	No	–	0	–	–

Details of Sync Manager 3 Synchronization objects

Sub	Name	Description
01h	Synchronization Type	00h: Free Run mode (asynchronous) 02h: DC mode (SYNC0 event synchronization) 22h: Sync Manager 2 event synchronization mode
02h	Cycle Time [ns]	Indicates the Cycle Time of the SYNC0 event.
03h	Shift Time [ns]	The Shift Time is not supported. The read value is always 0.
04h	Synchronization Types supported	Indicates the Synchronization Type supported. Bit0: Free Run mode (asynchronous) Bit1: Sync Manager 2 event synchronization mode Bit2: DC mode (SYNC0 event synchronization)
05h	Minimum Cycle Time [ns]	Indicates the Minimum Cycle Time supported.
06h	Calc and Copy Time [ns]	Indicates the minimum value of the internal calculation and copy time that is needed from the SYNC0 event to the Sync manager 3 event.
09h	Delay Time [ns]	The Delay Time is not supported. The read value is always 0.
20h	Sync Error	Changes to 1 if the Sync Error is detected.

2-2 Object list

Index	Sub	Name	Type	Access	PDO	Save	Initial value	Range	Update
1000h	00h	Device Type	U32	RO	No	–	0002 0192h	–	–
1001h	00h	Error Register	U8	RO	No	–	0	–	–
1008h	00h	Manufacturer Device Name	STRING	RO	No	–	AZXD-SED		–
1009h	00h	Manufacturer Hardware Version	STRING	RO	No	–	Indicates the version number	–	–
100Ah	00h	Manufacturer Software Version	STRING	RO	No	–	Indicates the version number	–	–
Identity Object									
1018h	00h	Number of entries	U8	RO	No	–	4	–	–
	01h	Vendor ID	U32	RO	No	–	0000 02BEh	–	–
	02h	Product Code	U32	RO	No	–	0000 142Dh		–
	03h	Revision Number	U32	RO	No	–	0000 xxxxh	–	–
	04h	Serial Number	U32	RO	No	–	0	–	–
Receive PDO mapping 1 (RxPDO1)									
1600h	00h	Number of entries	U8	RW	No	–	3	0 to 16	A
	01h	Mapping entry 1	U32	RW	No	–	6040 0010h	0000 0000h to FFFF FFFFh	A
	02h	Mapping entry 2	U32	RW	No	–	607A 0020h	0000 0000h to FFFF FFFFh	A
	03h	Mapping entry 3	U32	RW	No	–	6060 0008h	0000 0000h to FFFF FFFFh	A
	04h to 10h	Mapping entry 4 to 16	U32	RW	No	–	0000 0000h	0000 0000h to FFFF FFFFh	A
Receive PDO mapping 2 (RxPDO2)									
1601h	00h	Number of entries	U8	RW	No	–	5	0 to 16	A
	01h	Mapping entry 1	U32	RW	No	–	6040 0010h	0000 0000h to FFFF FFFFh	A
	02h	Mapping entry 2	U32	RW	No	–	607A 0020h	0000 0000h to FFFF FFFFh	A
	03h	Mapping entry 3	U32	RW	No	–	60FF 0020h	0000 0000h to FFFF FFFFh	A
	04h	Mapping entry 4	U32	RW	No	–	6060 0008h	0000 0000h to FFFF FFFFh	A
	05h	Mapping entry 5	U32	RW	No	–	60B8 0010h	0000 0000h to FFFF FFFFh	A
	06h to 10h	Mapping entry 6 to 16	U32	RW	No	–	0000 0000h	0000 0000h to FFFF FFFFh	A
Transmit PDO mapping 1 (TxPDO1)									
1A00h	00h	Number of entries	U8	RW	No	–	3	0 to 16	A
	01h	Mapping entry 1	U32	RW	No	–	6041 0010h	0000 0000h to FFFF FFFFh	A
	02h	Mapping entry 2	U32	RW	No	–	6064 0020h	0000 0000h to FFFF FFFFh	A
	03h	Mapping entry 3	U32	RW	No	–	6061 0008h	0000 0000h to FFFF FFFFh	A
	04h to 10h	Mapping entry 4 to 16	U32	RW	No	–	0000 0000h	0000 0000h to FFFF FFFFh	A
Transmit PDO mapping 2 (TxPDO2)									
1A01h	00h	Number of entries	U8	RW	No	–	8	0 to 16	A
	01h	Mapping entry 1	U32	RW	No	–	6041 0010h	0000 0000h to FFFF FFFFh	A
	02h	Mapping entry 2	U32	RW	No	–	6064 0020h	0000 0000h to FFFF FFFFh	A
	03h	Mapping entry 3	U32	RW	No	–	6061 0008h	0000 0000h to FFFF FFFFh	A
	04h	Mapping entry 4	U32	RW	No	–	60B9 0010h	0000 0000h to FFFF FFFFh	A
	05h	Mapping entry 5	U32	RW	No	–	60BA 0020h	0000 0000h to FFFF FFFFh	A
	06h	Mapping entry 6	U32	RW	No	–	60BC 0020h	0000 0000h to FFFF FFFFh	A
	07h	Mapping entry 7	U32	RW	No	–	603F 0010h	0000 0000h to FFFF FFFFh	A
	08h	Mapping entry 8	U32	RW	No	–	60FD 0020h	0000 0000h to FFFF FFFFh	A
09h to 10h	Mapping entry 9 to 16	U32	RW	No	–	0000 0000h	0000 0000h to FFFF FFFFh	A	

Objects of CoE communication area

Index	Sub	Name	Type	Access	PDO	Save	Initial value	Range	Update
1C00h	Sync manager communication type								
	00h	Number of entries	U8	RO	No	-	4	-	-
	01h	Communication type sync manager 0	U8	RO	No	-	1: Mailbox output (MainDevice to driver)		-
	02h	Communication type sync manager 1	U8	RO	No	-	2: Mailbox input (Driver to MainDevice)		-
	03h	Communication type sync manager 2	U8	RO	No	-	3: Process data output (MainDevice to driver)		-
	04h	Communication type sync manager 3	U8	RO	No	-	4: Process data input (Driver to MainDevice)		-
1C12h	Sync Manager 2 PDO assignment								
	00h	Number of entries	U8	RW	No	-	1	0, 1	A
	01h	Index of assigned PDO 1	U16	RW	No	-	1600h	0 to FFFFh	A
1C13h	Sync Manager 3 PDO assignment								
	00h	Number of entries	U8	RW	No	-	1	0, 1	A
	01h	Index of assigned PDO 1	U16	RW	No	-	1A00h	0 to FFFFh	A
1C32h	Sync Manager 2 Synchronization								
	00h	Number of entries	U8	RO	No	-	20h	-	-
	01h	Synchronization Type	U16	RW	No	-	02h	00h: Free Run mode (asynchronous) 01h: Sync manager 2 event synchronization mode 02h: DC mode (SYNC0 event synchronization)	A
	02h	Cycle Time [ns]	U32	RO	No	-	-	-	-
	03h	Shift Time [ns]	U32	RO	No	-	0	-	-
	04h	Synchronization Types supported	U16	RO	No	-	0007h	-	-
	05h	Minimum Cycle Time [ns]	U32	RO	No	-	0003 D090h (250,000 ns)		-
	06h	Calc and Copy Time [ns]	U32	RO	No	-	0001 86A0h (100,000 ns)		-
	07h	Reserved	U32	-	-	-	-	-	-
	08h	Reserved	U16	-	-	-	-	-	-
	09h	Delay Time [ns]	U32	RO	No	-	0	-	-
	0Ah to 1Fh	Reserved	U16	-	-	-	-	-	-
	20h	Sync Error	BOOL	RO	No	-	0	-	-

Index	Sub	Name	Type	Access	PDO	Save	Initial value	Range	Update
1C33h	Sync Manager 3 Synchronization								
	00h	Number of entries	U8	RO	No	–	20h	–	–
	01h	Synchronization Type	U16	RW	No	–	02h	00h: Free Run mode (asynchronous) 02h: DC mode (SYNC0 event synchronization) 22h: Sync manager 2 event synchronization mode	A
	02h	Cycle Time [ns]	U32	RO	No	–	–	–	–
	03h	Shift Time [ns]	U32	RO	No	–	0	–	–
	04h	Synchronization Types supported	U16	RO	No	–	0007h	–	–
	05h	Minimum Cycle Time [ns]	U32	RO	No	–	0003 D090h (250,000 ns)		–
	06h	Calc and Copy Time [ns]	U32	RO	No	–	0002 49F0h (150,000 ns)		–
	07h	Reserved	U32	–	–	–	–	–	–
	08h	Reserved	U16	–	–	–	–	–	–
	09h	Delay Time [ns]	U32	RO	No	–	0	–	–
	0Ah to 1Fh	Reserved	U16	–	–	–	–	–	–
	20h	Sync Error	BOOL	RO	No	–	0	–	–

3 Objects of profile area

Objects in the profile area are defined by the CiA402 drive profile. These are used to set the driver operation and to indicate the status.

3-1 Descriptions of each object

- **Error code (603Fh)**

This indicates the error code being generated in the driver.

Index	Sub	Type	Access	PDO	Save	Initial value	Range	Update
603Fh	00h	U16	RO	TxPDO	–	–	–	–



If an alarm is generated in the driver, an error code is indicated. The lower 8 bits of the error code represents the alarm code, and the upper 8 bits represents FFh. "0000h" is indicated when an alarm is not generated. Refer to p.198 for alarm codes.

- **Controlword (6040h)**

This is used to control the transition of the drive state machine, start/stop of operation, etc.

Index	Sub	Type	Access	PDO	Save	Initial value	Range	Update
6040h	00h	U16	RW	RxPDO	–	0000h	0000h to FFFFh	A

Details of range

Bit	Name	Description
0	Switch on	Controls the status of the drive state machine. Refer to "State transition of drive state machine" on p.72 for details.
1	Enable voltage	
2	Quick stop	
3	Enable operation	
4	Operation mode specific	It varies depending on the operation mode. Refer to each operation mode of "3 Drive profile" on p.71 for details.
5		
6		
7	Fault reset	Resets the alarm when changing from 0 to 1.
8	Halt	Refer to each operation mode of "3 Drive profile" on p.71 for details.
9	Operation mode specific	
10	Reserved	Reserved
11	Manufacturer specific	Manufacturer-specific bit. Refer to each operation mode of "3 Drive profile" on p.71 for details.
12		
13		
14		
15		

● Statusword (6041h)

This is used to indicate the status of the drive state machine and the operation status of the driver.

Index	Sub	Type	Access	PDO	Save	Initial value	Range	Update
6041h	00h	U16	RO	TxPDO	–	–	–	–

Details of range

Bit	Name	Description
0	Ready to switch on	Indicates the status of the drive state machine. Refer to "Status output of drive state machine" on p.73 for details.
1	Switched on	
2	Operation enabled	
3	Fault	
4	Voltage enabled	
5	Quick stop	
6	Switch on disabled	
7	Warning	Changes to 1 if information of the driver is generated. When the information status is resolved, it is automatically cleared to 0.
8	Manufacturer specific	Manufacturer-specific bit. Refer to each operation mode of "3 Drive profile" on p.71 for details.
9	Remote	Changes to 1 when the driver initialization is completed.
10	Target reached	It varies depending on the operation mode. Refer to each operation mode of "3 Drive profile" on p.71 for details.
11	Internal limit active	Indicates the status of the function limitation by the internal limit. Refer to each operation mode of "3 Drive profile" on p.71 for details.
12	Operation mode specific	It varies depending on the operation mode. Refer to each operation mode of "3 Drive profile" on p.71 for details.
13		
14	Manufacturer specific	Manufacturer-specific bit. Refer to each operation mode of "3 Drive profile" on p.71 for details.
15		

● Quick stop option code (605Ah)

This used to set the action by the Quick stop command. When the setting is changed while the Quick stop is being operated, the new setting is updated after stop.

Index	Sub	Type	Access	PDO	Save	Initial value	Range	Update
605Ah	00h	INT16	RW	No	○	2	0, 1, 2, 3, 5, 6, 7	A

Details of range

Setting value	Description
0	Non-excitation
1	Decelerates to a stop according to the Profile deceleration (6084h). Transitions to "Switch on disabled" after stop.
2	Decelerates to a stop according to the Quick stop deceleration (6085h). Transitions to "Switch on disabled" after stop.
3	The motor stops immediately. Transitions to "Switch on disabled" after stop.
5	Decelerates to a stop according to the Profile deceleration (6084h). Keeps "Quick stop active" after stop.
6	Decelerates to a stop according to the Quick stop deceleration (6085h). Keeps "Quick stop active" after stop.
7	The motor stops immediately. Keeps "Quick stop active" after stop.



If the Quick stop command is executed while the motor decelerates to a stop, the deceleration switches to the Quick stop deceleration. However, when the deceleration stop is performed by the STOP input signal, the deceleration will not switch even if the Quick stop command is executed.

● **Shutdown option code (605Bh)**

This is used to set the action when transitioning from “Operation enabled” to “Ready to switch on.”

Index	Sub	Type	Access	PDO	Save	Initial value	Range	Update
605Bh	00h	INT16	RW	No	○	1	0: Non-excitation 1: Decelerates to a stop according to the Profile deceleration (6084h). The motor goes into a non-excitation state after it stops.	A

● **Disable operation option code (605Ch)**

This is used to set the action when transitioning from “Operation enabled” to “Switched on.”

Index	Sub	Type	Access	PDO	Save	Initial value	Range	Update
605Ch	00h	INT16	RW	No	○	1	0: Non-excitation 1: Decelerates to a stop according to the Profile deceleration (6084h). The motor goes into a non-excitation state after it stops.	A

● **Halt option code (605Dh)**

This is used to set the action when Halt (bit 8) of the Controlword (6040h) was set.

Index	Sub	Type	Access	PDO	Save	Initial value	Range	Update
605Dh	00h	INT16	RW	No	○	1	1: Decelerates to a stop according to the Profile deceleration (6084h). Keeps “Operation enabled” after stop. 2: Decelerates to a stop according to the Quick stop deceleration (6085h). Keeps “Operation enabled” after stop. 3: Stops immediately. Keeps “Operation enabled” after stop.	A

● **Modes of operation (6060h)**

This is used to set the operation mode of the driver. Change the operation mode while the motor is stopped. When the setting is changed during operation, the new setting is updated after stop.

Index	Sub	Type	Access	PDO	Save	Initial value	Range	Update
6060h	00h	INT8	RW	RxPDO	○	0	0: Operation function disable 1: Profile position mode (PP) 3: Profile velocity mode (PV) 6: Homing mode (HM) 8: Cyclic synchronous position mode (CSP) 9: Cyclic synchronous velocity mode (CSV)	B

● **Modes of operation display (6061h)**

This indicates the operation mode that is enabled actually. The range is the same as the Modes of operation (6060h).

Index	Sub	Type	Access	PDO	Save	Initial value	Range	Update
6061h	00h	INT8	RO	TxPDO	–	–	–	–

● **Position demand value (6062h)**

This indicates the command position. When the Wrap (RND) setting (41C7h) is set to 1, the value within the wrap range is indicated.

Index	Sub	Type	Access	PDO	Save	Initial value	Range	Update
6062h	00h	INT32	RO	TxPDO	–	–	–	–

● **Position actual value (6064h)**

This indicates the present position detected by the ABZO sensor. When the Wrap (RND) setting (41C7h) is set to 1, the value within the wrap range is indicated.

Index	Sub	Type	Access	PDO	Save	Initial value	Range	Update
6064h	00h	INT32	RO	TxPDO	–	–	–	–

- **Following error window (6065h)**

This is used to set the condition under which the position deviation alarm is generated.

Index	Sub	Type	Access	PDO	Save	Initial value	Range	Update
6065h	00h	U32	RW	No	○	300	1 to 30,000 (1=0.01 rev)	A

- **Position window (6067h)**

This is used to set the output range of the positioning completion output (IN-POS). It is the same as the “IN-POS positioning completion signal range” parameter of the **AZX** Series and **AZ** Series.

In the Profile position mode, after positioning operation is properly completed, the Target Reached (6041h: bit 10) of the Statusword changes to 1 when the actual position has converged in a range of the Position window (6067h) with respect to the Position demand value (command position).

The IN-POS output range can be offset by the IN-POS positioning completion signal offset (4704h).

Index	Sub	Type	Access	PDO	Save	Initial value	Range	Update
6067h	00h	U32	RW	No	○	18	1 to 180 (1=0.1°)	A

- **Velocity demand value (606Bh)**

This indicates the present command speed (Hz).

Index	Sub	Type	Access	PDO	Save	Initial value	Range	Update
606Bh	00h	INT32	RO	TxPDO	–	–	–	–

- **Velocity actual value (606Ch)**

This indicates the present feedback speed (Hz).

Index	Sub	Type	Access	PDO	Save	Initial value	Range	Update
606Ch	00h	INT32	RO	TxPDO	–	–	–	–

- **Max torque (6072h)**

Sets the torque limiting value for the operation data.

Index	Sub	Type	Access	PDO	Save	Initial value	Range	Update
6072h	00h	U16	RW	RxPDO	○	1,000	0 to 10,000 (1=0.1 %)	A

- **Torque actual value (6077h)**

This indicates the output torque presently generated as a percentage of the rated torque. (1=0.1 %)

It is the same as the Torque monitor (406Bh).

Index	Sub	Type	Access	PDO	Save	Initial value	Range	Update
6077h	00h	INT16	RO	TxPDO	–	–	–	–

- **Target position (607Ah)**

This is used to set the target position in the Cyclic synchronous position mode and the Profile position mode.

Index	Sub	Type	Access	PDO	Save	Initial value	Range	Update
607Ah	00h	INT32	RW	RxPDO	–	0	–2,147,483,648 to 2,147,483,647 (step)	A

- **Home offset (607Ch)**

This is used to offset the home after return-to-home operation is completed in the Homing mode. The command position and the feedback position after completion of return-to-home will be the value set in the Home offset. Since the offset value is written to the same register as the Preset position (41C6h), if the Home offset (607Ch) is changed, the Preset position (41C6h) will be the same value.

Index	Sub	Type	Access	PDO	Save	Initial value	Range	Update
607Ch	00h	INT32	RW	No	○	0	–2,147,483,648 to 2,147,483,647 (step)	A

- **Software position limit (607Dh)**

This is used to set the software limit. The Min position limit represents the limit of the reverse direction, and the Max position limit represents the limit of the forward direction.

Index	Sub	Name	Type	Access	PDO	Save	Initial value	Range	Update
607Dh	00h	Number of entries	U8	RO	No	–	2	–	–
	01h	Min position limit	INT32	RW	No	○	–2,147,483,648	–2,147,483,648 to	A
	02h	Max position limit	INT32	RW	No	○	2,147,483,647	2,147,483,647 (step)	A

- **Profile velocity (6081h)**

This is used to set the operating speed for the Profile position mode.

Index	Sub	Type	Access	PDO	Save	Initial value	Range	Update
6081h	00h	U32	RW	RxPDO	○	10,000	0 to 4,000,000 [Hz]	A

- **Profile acceleration (6083h)**

This is used to set the acceleration for the Profile position mode and the Profile velocity mode.

Index	Sub	Type	Access	PDO	Save	Initial value	Range	Update
6083h	00h	U32	RW	RxPDO	○	300,000	1 to 1,000,000,000 (step/s ²)	B

- **Profile deceleration (6084h)**

This is used to set the deceleration for the Profile position mode and the Profile velocity mode.

Index	Sub	Type	Access	PDO	Save	Initial value	Range	Update
6084h	00h	U32	RW	RxPDO	○	300,000	1 to 1,000,000,000 (step/s ²)	B

- **Quick stop deceleration (6085h)**

This is used to set the deceleration for the Quick stop. This is the deceleration when the Quick stop command of the drive state machine was enabled while the Quick stop option code (605Ah) was set to 2 or 6.

Index	Sub	Type	Access	PDO	Save	Initial value	Range	Update
6085h	00h	U32	RW	RxPDO	○	1,000,000	1 to 1,000,000,000 (step/s ²)	B

- **Gear ratio (6091h)**

This is used to set the electronic gear. The electronic gear A is the denominator of the electronic gear, and the electronic gear B is the numerator of the electronic gear.

If the Gear ratio (6091h) is set, the resolution per revolution of the motor output shaft can be changed. Refer to “4-2 Resolution” on p.107 for details.

Index	Sub	Name	Type	Access	PDO	Save	Initial value	Range	Update
6091h	00h	Number of entries	U8	RO	No	–	2	–	–
	01h	Electronic gear A	U32	RW	No	○	1	1 to 65,535	C
	02h	Electronic gear B	U32	RW	No	○	1		C

● Homing method (6098h)

This is used to set the return-to-home method for return-to-home operation. Refer to p.93 for details.

Index	Sub	Type	Access	PDO	Save	Initial value	Range	Update
6098h	00h	INT8	RW	No	○	24	–1: Return-to-home operation of our specifications 17: Return-to-home with the limit sensor (FW-LS/RV-LS), to start running in the negative direction 18: Return-to-home with the limit sensor (FW-LS/RV-LS), to start running in the positive direction 24: Return-to-home with the home sensor (HOMES), to start running in the positive direction 28: Return-to-home with the home sensor (HOMES), to start running in the negative direction 35: Home preset* 37: Home preset*	B

* 35 and 37 perform the same action.

● Homing speed (6099h)

This is used to set the operating speed and feedback speed for return-to-home operation. The feedback speed is the operating speed when position adjustment is performed with the home finally.

Index	Sub	Name	Type	Access	PDO	Save	Initial value	Range	Update
6099h	00h	Number of entries	U8	RO	No	–	2	–	–
	01h	Speed during search for switch	U32	RW	No	○	10,000	1 to 4,000,000 [Hz]	B
	02h	Speed during search for zero	U32	RW	No	○	5,000	1 to 10,000 [Hz]	B

● Homing acceleration (609Ah)

This is used to set the acceleration/deceleration for return-to-home operation.

Index	Sub	Type	Access	PDO	Save	Initial value	Range	Update
609Ah	00h	U32	RW	No	○	300,000	1 to 1,000,000,000 (step/s ²)	B

● Touch probe function (60B8h)

This is used to set the action of the touch probe. Refer to p.104 for details.

Index	Sub	Type	Access	PDO	Save	Initial value	Range	Update
60B8h	00h	U16	RW	RxPDO	–	0000h	0000h to FFFFh	A

Details of range

Bit	Name	Value	Description
0	Touch probe 1 permission	0	Disables the touch probe 1.
		1	Enables the touch probe 1.
1	Touch probe 1 trigger action	0	First trigger action Latches only once on the first trigger.
		1	Continuous action Latches each time a trigger is input.
2	Touch probe 1 trigger selection	0	Sets the external latch input EXT1 as a trigger.
		1	Sets the ZSG output as a trigger.
3	Reserved	0	Reserved
4	Touch probe 1 positive value action	0	Disables the latch function on the positive value of a trigger.
		1	Enables the latch function on the positive value of a trigger.
5	Touch probe 1 negative value action	0	Disables the latch function on the negative value of a trigger.
		1	Enables the latch function on the negative value of a trigger.
6	Reserved	0	Reserved
7	Reserved	0	Reserved

Bit	Name	Value	Description
8	Touch probe 2 permission	0	Disables the touch probe 2.
		1	Enables the touch probe 2.
9	Touch probe 2 trigger action	0	First trigger action Latches only once on the first trigger.
		1	Continuous action Latches each time a trigger is input.
10	Touch probe 2 trigger selection	0	Sets the external latch input EXT2 as a trigger.
		1	Sets the ZSG output as a trigger.
11	Reserved	0	Reserved
12	Touch probe 2 positive value action	0	Disables the latch function on the positive value of a trigger.
		1	Enables the latch function on the positive value of a trigger.
13	Touch probe 2 negative value action	0	Disables the latch function on the negative value of a trigger.
		1	Enables the latch function on the negative value of a trigger.
14	Reserved	0	Reserved
15	Reserved	0	Reserved

● **Touch probe status (60B9h)**

This indicates the status of the touch probe. Refer to p.104 for details.

Index	Sub	Type	Access	PDO	Save	Initial value	Range	Update
60B9h	00h	U16	RO	TxPDO	–	–	–	–

Details of range

Bit	Name	Value	Description
0	Touch probe 1 permission status	0	The touch probe 1 is disabled.
		1	The touch probe 1 is enabled.
1	Touch probe 1 positive value latch	0	Has not latch on the positive value of the touch probe 1.
		1	Latched on the positive value of the touch probe 1.
2	Touch probe 1 negative value latch	0	Has not latch on the negative value of the touch probe 1.
		1	Latched on the negative value of the touch probe 1.
3 to 7	Reserved	0	Reserved
8	Touch probe 2 permission status	0	The touch probe 2 is disabled.
		1	The touch probe 2 is enabled.
9	Touch probe 2 positive value latch	0	Has not latch on the positive value of the touch probe 2.
		1	Latched on the positive value of the touch probe 2.
10	Touch probe 2 negative value latch	0	Has not latch on the negative value of the touch probe 2.
		1	Latched on the negative value of the touch probe 2.
11 to 15	Reserved	0	Reserved

● **Touch probe position 1 positive value (60BAh)**

This indicates the position latched on the positive value of the touch probe 1. (step)

Index	Sub	Type	Access	PDO	Save	Initial value	Range	Update
60BAh	00h	INT32	RO	TxPDO	–	–	–	–

● **Touch probe position 1 negative value (60BBh)**

This indicates the position latched on the negative value of the touch probe 1. (step)

Index	Sub	Type	Access	PDO	Save	Initial value	Range	Update
60BBh	00h	INT32	RO	TxPDO	–	–	–	–

- **Touch probe position 2 positive value (60BCh)**

This indicates the position latched on the positive value of the touch probe 2. (step)

Index	Sub	Type	Access	PDO	Save	Initial value	Range	Update
60BCh	00h	INT32	RO	TxPDO	–	–	–	–

- **Touch probe position 2 negative value (60BDh)**

This indicates the position latched on the negative value of the touch probe 2. (step)

Index	Sub	Type	Access	PDO	Save	Initial value	Range	Update
60BDh	00h	INT32	RO	TxPDO	–	–	–	–

- **Supported homing methods (60E3h)**

This indicates the Homing (return-to-home) method supported by the driver.

Index	Sub	Name	Type	Access	PDO	Save	Initial value	Range	Update
60E3h	00h	Number of entries	U8	RO	No	–	7	–	–
	01h	1st supported homing method	INT8	RO	No	–	17	–	–
	02h	2nd supported homing method	INT8	RO	No	–	18	–	–
	03h	3rd supported homing method	INT8	RO	No	–	24	–	–
	04h	4th supported homing method	INT8	RO	No	–	28	–	–
	05h	5th supported homing method	INT8	RO	No	–	35	–	–
	06h	6th supported homing method	INT8	RO	No	–	37	–	–
	07h	7th supported homing method	INT8	RO	No	–	–1	–	–

Details of range

Setting value	Description
–1	Return-to-home operation of Oriental Motor's specifications
17	Return-to-home with the limit sensor (FW-LS/RV-LS), to start running in the negative direction.
18	Return-to-home with the limit sensor (FW-LS/RV-LS), to start running in the positive direction.
24	Return-to-home with the home sensor (HOMES), to start running in the positive direction.
28	Return-to-home with the home sensor (HOMES), to start in the negative direction.
35, 37*	Home preset

* 35 and 37 perform the same action.

- **Following error actual value (60F4h)**

This indicates the deviation between the command position and the position actual value (feedback position). (step)

Index	Sub	Type	Access	PDO	Save	Initial value	Range	Update
60F4h	00h	INT32	RO	TxPDO	–	0	–	–

- **Digital inputs (60FDh)**

This indicates the status of direct I/O.

Index	Sub	Type	Access	PDO	Save	Initial value	Range	Update
60FDh	00h	U32	RO	TxPDO	–	–	–	–

Details of range

Bit	Name	Description
0	RV-BLK*1	Status of RV-BLK input (0: OFF, 1: ON)*2
1	FW-BLK*1	Status of FW-BLK input (0: OFF, 1: ON)*2
2	HOMES*1	Status of HOMES input (0: OFF, 1: ON)*2
3 to 15	–	Reserved
16	EXT1*1	Status of EXT1 input (0: OFF, 1: ON)*2
17	EXT2*1	Status of EXT2 input (0: OFF, 1: ON)*2
18, 19	–	Reserved

Bit	Name	Description
20	ZSG	Status of ZSG output (0: OFF, 1: ON)*2
21 to 23	–	Reserved
24	DIN0	Status of DIN0 input (0: Not carrying current, 1: Carrying current)*3
25	DIN1	Status of DIN1 input (0: Not carrying current, 1: Carrying current)*3
26	DIN2	Status of DIN2 input (0: Not carrying current, 1: Carrying current)*3
27	DIN3	Status of DIN3 input (0: Not carrying current, 1: Carrying current)*3
28	DIN4	Status of DIN4 input (0: Not carrying current, 1: Carrying current)*3
29	DIN5	Status of DIN5 input (0: Not carrying current, 1: Carrying current)*3
30, 31	–	Reserved

*1 To acquire the status, input signals are required to assign to the input terminals IN0 and IN5 of the I/O signal connector (CN7). Assign using the DIN0 input function (4840h) to the DIN5 input function (4845h).

*2 [Normally open] ON: Carrying current, OFF: Not carrying current

[Normally closed] ON: Not carrying current, OFF: Carrying current

*3 It represents a state of “Carrying current” or “Not carrying current” of the internal photocoupler.

● Digital outputs (60FEh)

This is used to control the electromagnetic brake.

Index	Sub	Name	Type	Access	PDO	Save	Initial value	Range	Update
60FEh	00h	Number of entries	U8	RO	No	–	2	–	–
	01h	Physical output	U32	RW	RxPDO	–	0000 0000h	0000 0000h to FFFF FFFFh	A
	02h	Bit mask	U32	RW	No	–	0000 0000h		A

Details of physical outputs

Bit	Name	Description
0	Electromagnetic brake control	0: Electromagnetic brake releasing 1: Electromagnetic brake holding
1 to 31	–	Reserved

Details of bit mask

Bit	Name	Description
0	Mask of bit 0	0: Brake control of physical outputs disable 1: Brake control of physical outputs enable
1 to 31	–	Reserved

● Target velocity (60FFh)

This is used to set the operating speed for the Cyclic synchronous velocity mode and the Profile velocity mode.

Index	Sub	Type	Access	PDO	Save	Initial value	Range	Update
60FFh	00h	INT32	RW	RxPDO	–	0	–4,000,000 to 4,000,000 (Hz)	A

● Supported drive modes (6502h)

This indicates the operation mode supported by the product.

Index	Sub	Type	Access	PDO	Save	Initial value	Range	Update
6502h	00h	U32	RO	No	–	0000 01A5h	–	–

Details of range

Bit	Name	Value	Description
0	PP (Profile position mode)	1	1: Supported
1	VL (Velocity mode)	0	0: Not supported
2	PV (Profile velocity mode)	1	1: Supported
3	TQ (Torque profile mode)	0	0: Not supported
4	Reserved	0	Reserved
5	HM (Homing mode)	1	1: Supported

Bit	Name	Value	Description
6	IP (Interpolated position mode)	0	0: Not supported
7	CSP (Cyclic synchronous position mode)	1	1: Supported
8	CSV (Cyclic synchronous velocity mode)	1	1: Supported
9	CST (Cyclic synchronous torque mode)	0	0: Not supported
10 to 31	Reserved	0	Reserved

3-2 Object list

Index	Sub	Name	Type	Access	PDO	Save	Initial value	Range	Update
603Fh	00h	Error code	U16	RO	TxPDO	–	–	–	–
6040h	00h	Controlword	U16	RW	RxPDO	–	0	0 to FFFFh	A
6041h	00h	Statusword	U16	RO	TxPDO	–	–	–	–
605Ah	00h	Quick stop option code	INT16	RW	No	○	2	0, 1, 2, 3, 5, 6, 7	A
605Bh	00h	Shutdown option code	INT16	RW	No	○	1	0: Non-excitation 1: Decelerates to a stop according to the Profile deceleration (6084h). The motor goes into a non-excitation state after stopping.	A
605Ch	00h	Disable operation option code	INT16	RW	No	○	1	0: Non-excitation 1: Decelerates to a stop according to the Profile deceleration (6084h). The motor goes into a non-excitation state after stopping.	A
605Dh	00h	Halt option code	INT16	RW	No	○	1	1: Decelerates to a stop according to the Profile deceleration (6084h). Keeps "Operation enabled" after stop. 2: Decelerates to a stop according to the Quick stop deceleration (6085h). Keeps "Operation enabled" after stop. 3: Stops immediately. Keeps "Operation enabled" after stop.	A
6060h	00h	Modes of operation	INT8	RW	RxPDO	○	0	0: Operation function disable 1: Profile position mode (PP) 3: Profile velocity mode (PV) 6: Homing mode (HM) 8: Cyclic synchronous position mode (CSP) 9: Cyclic synchronous velocity mode (CSV)	B
6061h	00h	Modes of operation display	INT8	RO	TxPDO	–	–	–	–
6062h	00h	Position demand value [step]	INT32	RO	TxPDO	–	–	–	–
6064h	00h	Position actual value [step]	INT32	RO	TxPDO	–	–	–	–
6065h	00h	Following error window [1=0.01 rev]	U32	RW	No	○	300	1 to 30,000	A
6067h	00h	Position window [1=0.1°]	U32	RW	No	○	18	0 to 180	A
606Bh	00h	Velocity demand value [Hz]	INT32	RO	TxPDO	–	–	–	–
606Ch	00h	Velocity actual value [Hz]	INT32	RO	TxPDO	–	–	–	–
6072h	00h	Max torque [1=0.1 %]	U16	RW	RxPDO	○	1,000	0 to 10,000	A
6077h	00h	Torque actual value [1=0.1 %]	INT16	RO	TxPDO	–	–	–	–

Objects of profile area

Index	Sub	Name	Type	Access	PDO	Save	Initial value	Range	Update
607Ah	00h	Target position [step]	INT32	RW	RxPDO	–	0	–2,147,483,648 to 2,147,483,647	A
607Ch	00h	Home offset [step]	INT32	RW	No	○	0	–2,147,483,648 to 2,147,483,647	A
607Dh	Positive software limit								
	00h	Number of entries	U8	RO	No	–	2	–	–
	01h	Min position limit [step]	INT32	RW	No	○	–2,147,483,648	–2,147,483,648 to 2,147,483,647	A
	02h	Max position limit [step]	INT32	RW	No	○	2,147,483,647	–2,147,483,648 to 2,147,483,647	A
6081h	00h	Profile velocity [Hz]	U32	RW	RxPDO	○	10,000	0 to 4,000,000	A
6083h	00h	Profile acceleration [step/s ²]	U32	RW	RxPDO	○	300,000	1 to 1,000,000,000	B
6084h	00h	Profile deceleration [step/s ²]	U32	RW	RxPDO	○	300,000	1 to 1,000,000,000	B
6085h	00h	Quick stop deceleration [step/s ²]	U32	RW	RxPDO	○	1,000,000	1 to 1,000,000,000	B
6091h	Gear ratio								
	00h	Number of entries	U8	RO	No	–	2	–	–
	01h	Electronic gear A	U32	RW	No	○	1	1 to 65,535	C
	02h	Electronic gear B	U32	RW	No	○	1	1 to 65,535	C
6098h	00h	Homing method	INT8	RW	No	○	24	–1, 17, 18, 24, 28, 35, 37	B
6099h	Homing speed								
	00h	Number of entries	U8	RO	No	–	2	–	–
	01h	Speed during search for switch [Hz]	U32	RW	No	○	10,000	1 to 4,000,000	B
	02h	Speed during search for zero [Hz]	U32	RW	No	○	5,000	1 to 10,000	B
609Ah	00h	Homing acceleration [step/s ²]	U32	RW	No	○	300,000	1 to 1,000,000,000	B
60B8h	00h	Touch probe function	U16	RW	RxPDO	–	0000h	0000h to FFFFh	A
60B9h	00h	Touch probe status	U16	RO	TxPDO	–	–	–	–
60BAh	00h	Touch probe position 1 positive value [step]	INT32	RO	TxPDO	–	–	–	–
60BBh	00h	Touch probe position 1 negative value [step]	INT32	RO	TxPDO	–	–	–	–
60BCh	00h	Touch probe position 2 positive value [step]	INT32	RO	TxPDO	–	–	–	–
60BDh	00h	Touch probe position 2 negative value [step]	INT32	RO	TxPDO	–	–	–	–
60E3h	Supported homing methods								
	00h	Number of entries	U8	RO	No	–	7	–	–
	01h	1st supported homing method	INT8	RO	No	–	17	–	–
	02h	2nd supported homing method	INT8	RO	No	–	18	–	–
	03h	3rd supported homing method	INT8	RO	No	–	24	–	–
	04h	4th supported homing method	INT8	RO	No	–	28	–	–
	05h	5th supported homing method	INT8	RO	No	–	35	–	–
	06h	6th supported homing method	INT8	RO	No	–	37	–	–
	07h	7th supported homing method	INT8	RO	No	–	–1	–	–
60F4h	00h	Following error actual value [step]	INT32	RO	TxPDO	–	0	–	–
60FDh	00h	Digital inputs	U32	RO	TxPDO	–	–	–	–

Index	Sub	Name	Type	Access	PDO	Save	Initial value	Range	Update
60FEh	Digital outputs								
	00h	Number of entries	U8	RO	No	–	2	–	–
	01h	Physical output	U32	RW	RxPDO	–	0000 0000h	0000 0000h to FFFF FFFFh	A
	02h	Bit mask	U32	RW	No	–	0000 0000h	0000 0000h to FFFF FFFFh	A
60FFh	00h	Target velocity [Hz]	INT32	RW	RxPDO	–	0	–4,000,000 to 4,000,000	A
6502h	00h	Supported drive modes	U32	RO	No	–	0000 01A5h	–	–

4 Objects of manufacturer-specific area

These are Oriental Motor's specific objects.

4-1 Descriptions of each object

- **Backup DATA access key (4020h)**

Inputs the key code to access the backup area. Data can be written and read.

Index	Sub	Type	Access	PDO	Save	Initial value	Range	Update
4020h	00h	INT32	RW	No	–	0	Key code: 20519253 (01391955h)	A

- **Backup DATA write key (4021h)**

Inputs the key code to write the data to the backup area.

Index	Sub	Type	Access	PDO	Save	Initial value	Range	Update
4021h	00h	INT32	RW	No	–	0	Key code: 1977326743 (75DB9C97h)	A

- **Driver input command (403Eh)**

This indicates an input command from the EtherCAT MainDevice to the driver.

Index	Sub	Type	Access	PDO	Save	Initial value	Range	Update
403Eh	00h	U16	RW	RxPDO	–	0	0000h to FFFFh	A

- **Driver output status (403Fh)**

The status of R-OUT0 to R-OUT15 can be checked.

Index	Sub	Type	Access	PDO	Save	Initial value	Range	Update
403Fh	00h	U16	RO	TxPDO	–	–	–	–

- **Present alarm (4040h)**

This indicates the alarm code presently being generated.

Index	Sub	Type	Access	PDO	Save	Initial value	Range	Update
4040h	00h	U16	RO	TxPDO	–	–	–	–

- **Alarm history 1 (4041h)**

This indicates the most recent item in the alarm history. When an alarm is being generated, its code is also indicated on the alarm history 1 simultaneously.

Index	Sub	Type	Access	PDO	Save	Initial value	Range	Update
4041h	00h	U16	RO	No	–	–	–	–

- **Alarm history 2 to 9 (4042h to 4049h)**

These indicate the items in the alarm history.

Index	Sub	Name	Type	Access	PDO	Save	Initial value	Range	Update
4042h	00h	Alarm history 2	U16	RO	No	–	–	–	–
4043h	00h	Alarm history 3	U16	RO	No	–	–	–	–
4044h	00h	Alarm history 4	U16	RO	No	–	–	–	–
4045h	00h	Alarm history 5	U16	RO	No	–	–	–	–
4046h	00h	Alarm history 6	U16	RO	No	–	–	–	–
4047h	00h	Alarm history 7	U16	RO	No	–	–	–	–
4048h	00h	Alarm history 8	U16	RO	No	–	–	–	–
4049h	00h	Alarm history 9	U16	RO	No	–	–	–	–

- **Alarm history 10 (404Ah)**

This indicates the oldest item in the alarm history.

Index	Sub	Type	Access	PDO	Save	Initial value	Range	Update
404Ah	00h	U16	RO	No	–	–	–	–

- **Command speed (4064h)**

This indicates the present command speed. (r/min)

Index	Sub	Type	Access	PDO	Save	Initial value	Range	Update
4064h	00h	INT32	RO	TxPDO	–	–	–	–

- **Feedback speed (4067h)**

This indicates the present feedback speed. (r/min)

Index	Sub	Type	Access	PDO	Save	Initial value	Range	Update
4067h	00h	INT32	RO	TxPDO	–	–	–	–

- **Direct I/O (406Ah)**

This indicates the status of direct I/O, the extended input, and the virtual input. (Arrangement of bits ⇒ p.110)

Index	Sub	Type	Access	PDO	Save	Initial value	Range	Update
406Ah	00h	U32	RO	TxPDO	–	–	–	–

- **Torque monitor (406Bh)**

This indicates the output torque presently generated as a percentage of the rated torque. (1=0.1 %)

Index	Sub	Type	Access	PDO	Save	Initial value	Range	Update
406Bh	00h	INT16	RO	TxPDO	–	–	–	–

- **Load factor monitor (406Ch)**

This indicates the output torque presently generated as a percentage of the maximum torque in the continuous duty region. (1=0.1 %)

Index	Sub	Type	Access	PDO	Save	Initial value	Range	Update
406Ch	00h	INT16	RO	TxPDO	–	–	–	–

- **Cumulative load monitor (406Dh)**

This indicates the integrated value of the load during operation (internal unit). The load is cumulated regardless of the rotation direction of the motor.

Index	Sub	Type	Access	PDO	Save	Initial value	Range	Update
406Dh	00h	INT32	RO	TxPDO	–	–	–	–

- **Torque limiting value (406Eh)**

This indicates the present torque limiting value. (1=0.1 %)

Index	Sub	Type	Access	PDO	Save	Initial value	Range	Update
406Eh	00h	INT16	RO	TxPDO	–	–	–	–

- **Present information (407Bh)**

This indicates the information code presently being generated.

Index	Sub	Type	Access	PDO	Save	Initial value	Range	Update
407Bh	00h	INT32	RO	TxPDO	–	–	–	–

● **Driver temperature (407Ch)**

This indicates the present driver temperature. (1=0.1 °C)

Index	Sub	Type	Access	PDO	Save	Initial value	Range	Update
407Ch	00h	INT16	RO	TxPDO	–	–	–	–

● **Motor temperature (407Dh)**

This indicates the present motor temperature. (1=0.1 °C)

Index	Sub	Type	Access	PDO	Save	Initial value	Range	Update
407Dh	00h	INT16	RO	TxPDO	–	–	–	–

● **Odometer (407Eh)**

This indicates the cumulative travel distance of the motor in revolutions. This cannot be cleared on the customer side. (1=0.1 kRev)

Index	Sub	Type	Access	PDO	Save	Initial value	Range	Update
407Eh	00h	INT32	RO	TxPDO	–	–	–	–

● **Tripmeter (407Fh)**

This indicates the travel distance of the motor in revolutions. This can be cleared on the customer side. (1=0.1 kRev)

Index	Sub	Type	Access	PDO	Save	Initial value	Range	Update
407Fh	00h	INT32	RO	TxPDO	–	–	–	–

● **Feedback position 32-bit counter (4090h)**

This is a 32-bit counter of the feedback position. It counts independently of the wrap function. It will return to within the wrap coordinates when the control power supply is turned on again.

Index	Sub	Type	Access	PDO	Save	Initial value	Range	Update
4090h	00h	INT32	RO	TxPDO	–	–	–	–

● **Command position 32-bit counter (4091h)**

This is a 32-bit counter of the command position. It counts independently of the wrap function. It will return to within the wrap coordinates when the control power supply is turned on again.

Index	Sub	Type	Access	PDO	Save	Initial value	Range	Update
4091h	00h	INT32	RO	TxPDO	–	–	–	–

● **Settling time (4096h)**

This is the amount of time from the completion of the command until the IN-POS output is turned ON. (ms)

Index	Sub	Type	Access	PDO	Save	Initial value	Range	Update
4096h	00h	INT32	RO	TxPDO	–	–	–	–

● **Main power supply count (40A0h)**

This indicates the number of times that the main power supply was turned on.

Index	Sub	Type	Access	PDO	Save	Initial value	Range	Update
40A0h	00h	INT32	RO	TxPDO	–	–	–	–

● **Main power supply time (40A1h)**

This indicates the time elapsed since the main power supply was turned on in minutes. (min)

Index	Sub	Type	Access	PDO	Save	Initial value	Range	Update
40A1h	00h	INT32	RO	TxPDO	–	–	–	–

- **Control power supply count (40A2h)**

This indicates the number of times that the control power supply was turned on.

Index	Sub	Type	Access	PDO	Save	Initial value	Range	Update
40A2h	00h	INT32	RO	TxPDO	–	–	–	–

- **Inverter voltage (40A3h)**

This indicates the inverter voltage of the driver. (1=0.1 V)

Index	Sub	Type	Access	PDO	Save	Initial value	Range	Update
40A3h	00h	INT16	RO	TxPDO	–	–	–	–

- **Elapsed time from BOOT (40A9h)**

This indicates the time elapsed since the control power supply was turned on. (ms)

Index	Sub	Type	Access	PDO	Save	Initial value	Range	Update
40A9h	00h	INT32	RO	TxPDO	–	–	–	–

- **I/O status 1 to 8 (40B8h to 40BFh)**

This indicates the ON-OFF status of the internal I/O. (Arrangement of bits ⇨ p.111)

Index	Sub	Name	Type	Access	PDO	Save	Initial value	Range	Update
40B8h	00h	I/O status 1	U32	RO	TxPDO	–	–	–	–
40B9h	00h	I/O status 2	U32	RO	TxPDO	–	–	–	–
40BAh	00h	I/O status 3	U32	RO	TxPDO	–	–	–	–
40BBh	00h	I/O status 4	U32	RO	TxPDO	–	–	–	–
40BCh	00h	I/O status 5	U32	RO	TxPDO	–	–	–	–
40BDh	00h	I/O status 6	U32	RO	TxPDO	–	–	–	–
40BEh	00h	I/O status 7	U32	RO	TxPDO	–	–	–	–
40BFh	00h	I/O status 8	U32	RO	TxPDO	–	–	–	–

- **Alarm reset (40C0h)**

Resets the alarm being generated presently. Some alarms cannot be reset.

Index	Sub	Type	Access	PDO	Save	Initial value	Range	Update
40C0h	00h	U8	RW	No	–	0	0: Not executed. 1: A command is executed when the data changes from 0 to 1. 2: A command is executed. It will automatically return to 1 after executing.	–

- **Clear alarm history (40C2h)**

Clears the alarm history.

Index	Sub	Type	Access	PDO	Save	Initial value	Range	Update
40C2h	00h	U8	RW	No	–	0	–	–

- **P-PRESET execution (40C5h)**

Presets the command position.

Index	Sub	Type	Access	PDO	Save	Initial value	Range	Update
40C5h	00h	U8	RW	No	–	0	–	–

- **Configuration (40C6h)**

Executes recalculation and setup of the parameter.

Index	Sub	Type	Access	PDO	Save	Initial value	Range	Update
40C6h	00h	U8	RW	No	–	0	–	–

- **Read batch NV memory (40C8h)**

Reads the parameters stored in the non-volatile memory to the RAM. All operation data and parameters stored in the RAM are overwritten.

Index	Sub	Type	Access	PDO	Save	Initial value	Range	Update
40C8h	00h	U8	RW	No	–	0	–	–

- **Write batch NV memory (40C9h)**

Writes the parameters stored in the RAM to the non-volatile memory. The non-volatile memory can be rewritten approximately 100,000 times.

Index	Sub	Type	Access	PDO	Save	Initial value	Range	Update
40C9h	00h	U8	RW	No	–	0	–	–

- **All data batch initialization (40CAh)**

Restores all parameters stored in the non-volatile memory to their initial values.

Index	Sub	Type	Access	PDO	Save	Initial value	Range	Update
40CAh	00h	U8	RW	No	–	0	–	–

- **Read from backup (40CBh)**

Reads all the data from the backup area.

Index	Sub	Type	Access	PDO	Save	Initial value	Range	Update
40CBh	00h	U8	RW	No	–	0	–	–

- **Write to backup (40CCh)**

Writes all the data to the backup area.

Index	Sub	Type	Access	PDO	Save	Initial value	Range	Update
40CCh	00h	U8	RW	No	–	0	–	–

- **Clear latch information (40CDh)**

Clears the latch information.

Index	Sub	Type	Access	PDO	Save	Initial value	Range	Update
40CDh	00h	U8	RW	No	–	0	–	–

- **Clear tripmeter (40CFh)**

Clears the tripmeter.

Index	Sub	Type	Access	PDO	Save	Initial value	Range	Update
40CFh	00h	U8	RW	No	–	0	–	–

- **Execute ETO-CLR input (40D0h)**

Turns both the HWT01 and HWT02 inputs ON to release the power removal function, and then puts the motor in an excitation state.

Index	Sub	Type	Access	PDO	Save	Initial value	Range	Update
40D0h	00h	U8	RW	No	–	0	–	–

- **ZSG-PRESET (40D1h)**

Sets the position of phase Z again.

Index	Sub	Type	Access	PDO	Save	Initial value	Range	Update
40D1h	00h	U8	RW	No	–	0	–	–

- **Clear ZSG-PRESET (40D2h)**

Clears the position data of phase Z that was set again with the "ZSG-PRESET" command.

Index	Sub	Type	Access	PDO	Save	Initial value	Range	Update
40D2h	00h	U8	RW	No	–	0	–	–

- **Clear information (40D3h)**

Clears the information.

Index	Sub	Type	Access	PDO	Save	Initial value	Range	Update
40D3h	00h	U8	RW	No	–	0	–	–

- **Clear information history (40D4h)**

Clears the information history.

Index	Sub	Type	Access	PDO	Save	Initial value	Range	Update
40D4h	00h	U8	RW	No	–	0	–	–

- **Load inertia setting mode selection (4120h)**

Selects the setting method of the load inertia.

Index	Sub	Type	Access	PDO	Save	Initial value	Range	Update
4120h	00h	INT8	RW	No	○	1	0: Load inertia setting (4121h) is used 1: Automatic	A

- **Load inertia setting (4121h)**

Sets the ratio of the load inertia to the motor rotor inertia. When the rotor inertia is equal to the load inertia, the ratio is 100 %.

Index	Sub	Type	Access	PDO	Save	Initial value	Range	Update
4121h	00h	INT16	RW	No	○	0	0 to 10,000 %	A

- **Mechanical rigidity setting (4124h)**

Sets the rigidity of equipment. The motor response improves as the setting value increases. An excessively high value may cause the motor to vibrate or to generate noise.

Index	Sub	Type	Access	PDO	Save	Initial value	Range	Update
4124h	00h	INT8	RW	No	○	6	0 to 15	A

- **Command filter setting (4129h)**

Sets the filter function to adjust the motor response.

Index	Sub	Type	Access	PDO	Save	Initial value	Range	Update
4129h	00h	INT8	RW	No	○	1	1: LPF (Speed filter) 2: Moving average filter	B

- **Command filter time constant (412Ah)**

Adjusts the motor response.

Index	Sub	Type	Access	PDO	Save	Initial value	Range	Update
412Ah	00h	INT16	RW	RxPDO	○	1	0 to 200 ms	B

- **Motor response setting (412Eh)**

Selects the setting method of the motor response in reaction to the command. (⇒ p.214)

Index	Sub	Type	Access	PDO	Save	Initial value	Range	Update
412Eh	00h	INT8	RW	No	○	6	–1: Manual setting 0 to 15	A

- **Position loop gain (412Fh)**

Adjusts the motor response in reaction to the position deviation. Increasing the value will make the deviation between the command position and the actual position smaller. An excessively large value may increase the motor overshoot or cause the motor vibration.

Index	Sub	Type	Access	PDO	Save	Initial value	Range	Update
412Fh	00h	INT16	RW	No	○	8	1 to 50 Hz	A

- **Speed loop gain (4130h)**

Adjusts the motor response in reaction to the speed deviation. Increasing the value will make the deviation between the command speed and the actual speed smaller. An excessively large value may increase the motor overshoot or cause the motor vibration.

Index	Sub	Type	Access	PDO	Save	Initial value	Range	Update
4130h	00h	INT16	RW	No	○	82	1 to 500 Hz	A

- **Speed loop integral time constant (4131h)**

Reduces the deviation that cannot be adjusted with the speed loop gain. An excessively long value may slow the motor response. Too short value may cause the motor vibration.

Index	Sub	Type	Access	PDO	Save	Initial value	Range	Update
4131h	00h	INT16	RW	No	○	1,940	1 to 10,000 (1=0.01 ms)	A

- **Electronic damper function (4136h)**

Sets the vibration suppression function.

Index	Sub	Type	Access	PDO	Save	Initial value	Range	Update
4136h	00h	INT8	RW	No	○	1	0: Disable 1: Enable	A

- **Torque filter (LPF) (413Ah)**

Changes the motor response at high frequencies.

Index	Sub	Type	Access	PDO	Save	Initial value	Range	Update
413Ah	00h	INT16	RW	No	○	820	0 to 4,700 Hz	A

- **Speed feed-forward (413Bh)**

When the speed is constant, the deviation between the command position and the actual position can be reduced to shorten the settling time. If it is set to 100 %, the deviation will be approximately 0. However, an excessively high value may increase the motor overshoot or cause the motor vibration.

Index	Sub	Type	Access	PDO	Save	Initial value	Range	Update
413Bh	00h	U8	RW	No	○	80	0 to 100 %	A

- **Starting speed (4142h)**

Sets the starting speed for the Profile position mode (PP) and the Profile velocity mode (PV).

Index	Sub	Type	Access	PDO	Save	Initial value	Range	Update
4142h	00h	INT32	RW	No	○	5,000	0 to 4,000,000 Hz	B

- **Permission of absolute positioning without setting absolute coordinates (4148h)**

Permits absolute positioning operation in a state where coordinates are not set.

Index	Sub	Type	Access	PDO	Save	Initial value	Range	Update
4148h	00h	U8	RW	No	○	0	0: Disable 1: Enable	B

- **Operation selection after stopping in speed control mode (414 Ch)**

Sets the stopping movement for the Profile velocity mode (PV) and the Cyclic synchronous velocity mode (CSV).

Index	Sub	Type	Access	PDO	Save	Initial value	Range	Update
414Ch	00h	U8	RW	No	○	0	0: Position loop disable 1: Position loop enable	B

- **Wrap positioning mode (414Fh)**

Sets the operation type for wrap positioning operation.

Index	Sub	Type	Access	PDO	Save	Initial value	Range	Update
414Fh	00h	U8	RW	RxPDO	○	0	0: Wrap absolute positioning 1: Wrap proximity 2: Wrap forward direction 3: Wrap reverse direction	B

- **(JOG) Operating speed (4151h)**

Sets the operating speed for JOG operation and inching operation.

Index	Sub	Type	Access	PDO	Save	Initial value	Range	Update
4151h	00h	INT32	RW	No	○	10,000	1 to 4,000,000 Hz	B

- **(JOG) Acceleration/deceleration (4152h)**

Sets the acceleration/deceleration rate or the acceleration/deceleration time for JOG macro operation.

Index	Sub	Type	Access	PDO	Save	Initial value	Range	Update
4152h	00h	INT32	RW	No	○	300,000	1 to 1,000,000,000 kHz/s	B

- **(JOG) Starting speed (4153h)**

Sets the starting speed for JOG macro operation.

Index	Sub	Type	Access	PDO	Save	Initial value	Range	Update
4153h	00h	INT32	RW	No	○	5,000	0 to 4,000,000 Hz	B

- **(JOG) Operating speed (high) (4154h)**

Sets the operating speed for high-speed JOG operation.

Index	Sub	Type	Access	PDO	Save	Initial value	Range	Update
4154h	00h	INT32	RW	No	○	50,000	1 to 4,000,000 Hz	B

- **(ZHOME) Operating speed (4158h)**

Sets the operating speed for high-speed return-to-home operation.

Index	Sub	Type	Access	PDO	Save	Initial value	Range	Update
4158h	00h	INT32	RW	No	○	50,000	1 to 4,000,000 Hz	B

- **(ZHOME) Acceleration/deceleration (4159h)**

Sets the acceleration/deceleration rate or the acceleration/deceleration time for high-speed return-to-home operation.

Index	Sub	Type	Access	PDO	Save	Initial value	Range	Update
4159h	00h	INT32	RW	No	○	300,000	1 to 1,000,000,000 kHz/s	B

- **(ZHOME) Starting speed (415Ah)**

Sets the starting speed for high-speed return-to-home operation.

Index	Sub	Type	Access	PDO	Save	Initial value	Range	Update
415Ah	00h	INT32	RW	No	○	5,000	0 to 4,000,000 Hz	B

● **JOG/HOME/ZHOME command filter time constant (415Eh)**

Sets the time constant for the command filter.

Index	Sub	Type	Access	PDO	Save	Initial value	Range	Update
415Eh	00h	INT16	RW	No	○	1	1 to 200 ms	B

● **(HOME) Return-to-home mode (4160h)**

Sets the return-to-home method.

Index	Sub	Type	Access	PDO	Save	Initial value	Range	Update
4160h	00h	U8	RW	No	○	1	0: 2-sensor 1: 3-sensor 2: One-way rotation	B

● **(HOME) Return-to-home starting direction (4161h)**

Sets the starting direction for detecting the home.

Index	Sub	Type	Access	PDO	Save	Initial value	Range	Update
4161h	00h	U8	RW	No	○	1	0: Negative side 1: Positive side	B

● **(HOME) Return-to-home starting speed (4163h)**

Sets the starting speed for return-to-home operation.

Index	Sub	Type	Access	PDO	Save	Initial value	Range	Update
4163h	00h	INT32	RW	No	○	5,000	1 to 4,000,000 Hz	B

● **(HOME) Return-to-home SLIT detection (4166h)**

Sets whether to use the SLIT input together when returning to the home.

Index	Sub	Type	Access	PDO	Save	Initial value	Range	Update
4166h	00h	U8	RW	No	○	0	0: Disable 1: Enable	B

● **(HOME) Return-to-home ZSG signal detection (4167h)**

Sets whether to use the ZSG input together when returning to the home.

Index	Sub	Type	Access	PDO	Save	Initial value	Range	Update
4167h	00h	U8	RW	No	○	0	0: Disable 2: ZSG	B

● **(HOME) Return-to-home position offset (4168h)**

Sets the amount of offset from the home.

Index	Sub	Type	Access	PDO	Save	Initial value	Range	Update
4168h	00h	INT32	RW	No	○	0	-2,147,483,647 to 2,147,483,647 steps	B

● **(HOME) Backward steps in 2 sensor return-to-home (4169h)**

Sets the amount of backward steps after return-to-home operation in 2-sensor mode.

Index	Sub	Type	Access	PDO	Save	Initial value	Range	Update
4169h	00h	INT32	RW	No	○	5,000	0 to 8,388,607 steps	B

● **(HOME) Operating amount in uni-directional return-to-home (416Ah)**

Sets the operating amount after return-to-home operation in one-way rotation mode.

Index	Sub	Type	Access	PDO	Save	Initial value	Range	Update
416Ah	00h	INT32	RW	No	○	5,000	0 to 8,388,607 steps	B

- **HWTO mode selection (4190h)**

Generates an alarm when the HWTO1 input or the HWTO2 input is turned OFF.

Index	Sub	Type	Access	PDO	Save	Initial value	Range	Update
4190h	00h	U8	RW	No	○	0	0: Alarm is not present 1: Alarm is present	A

- **HWTO delay time of checking dual system (4191h)**

Sets a threshold after either the HWTO1 input or the HWTO2 input is turned OFF until the other input is turned OFF. If the other input is not turned OFF even when the threshold is exceeded, an alarm will be generated.

Index	Sub	Type	Access	PDO	Save	Initial value	Range	Update
4191h	00h	U8	RW	No	○	0	0 to 10: Disable 11 to 100 ms	A

- **ETO reset ineffective period (4198h)**

Sets a time to disable the ETO-CLR input when the motor is excited by the ETO-CLR input after both the HWTO1 and HWTO2 inputs are turned ON. The motor cannot be excited until the time set in this parameter is exceeded even if the ETO-CLR input is turned ON.

Index	Sub	Type	Access	PDO	Save	Initial value	Range	Update
4198h	00h	U8	RW	No	○	0	0 to 100 ms	A

- **ETO reset action (ETO-CLR) (4199h)**

Sets the judgment criterion of the signal when the motor is excited by the ETO-CLR input.

Index	Sub	Type	Access	PDO	Save	Initial value	Range	Update
4199h	00h	U8	RW	No	○	1	1: ON edge 2: ON level	A

- **ETO reset action (ALM-RST) (419Ah)**

Excites the motor by the ALM-RST input after the HWTO1 input and the HWTO2 input are turned ON.

Index	Sub	Type	Access	PDO	Save	Initial value	Range	Update
419Ah	00h	U8	RW	No	○	0	0: Disable 1: Excitation at ON edge	A

- **ETO reset action (STOP) (419Ch)**

Excites the motor by the STOP input after the HWTO1 input and the HWTO2 input are turned ON.

Index	Sub	Type	Access	PDO	Save	Initial value	Range	Update
419Ch	00h	U8	RW	No	○	1	0: Disable 1: Excitation at ON edge	A

- **Driver temperature information (INFO-DRVTMP) (41A0h)**

Sets the condition under which the information is generated.

Index	Sub	Type	Access	PDO	Save	Initial value	Range	Update
41A0h	00h	INT16	RW	RxPDO	○	85	40 to 85 °C	A

- **Torque limiting time information (INFO-TLCTIME) (41A1h)**

Sets the condition under which the information is generated.

Index	Sub	Type	Access	PDO	Save	Initial value	Range	Update
41A1h	00h	INT16	RW	RxPDO	○	0	0: Disable 1 to 10,000 ms	A

● **Speed information (INFO-SPD) (41A2h)**

Sets the condition under which the information is generated.

Index	Sub	Type	Access	PDO	Save	Initial value	Range	Update
41A2h	00h	INT16	RW	RxPDO	○	0	0: Disable 1 to 12,000 r/min	A

● **Position deviation information (INFO-POSERR) (41A5h)**

Sets the condition under which the information is generated.

Index	Sub	Type	Access	PDO	Save	Initial value	Range	Update
41A5h	00h	INT16	RW	RxPDO	○	300	1 to 30,000 (1=0.01 rev)	A

● **Load factor information (INFO-LOAD) (41A6h)**

Sets the condition under which the information is generated.

Index	Sub	Type	Access	PDO	Save	Initial value	Range	Update
41A6h	00h	U16	RW	RxPDO	○	0	0: Disable 1 to 10,000 (1=0.1 %)	A

● **Torque information (INFO-TRQ) (41A7h)**

Sets the condition under which the information is generated.

Index	Sub	Type	Access	PDO	Save	Initial value	Range	Update
41A7h	00h	U16	RW	RxPDO	○	0	0: Disable 1 to 10,000 (1=0.1 %)	A

● **Motor temperature information (INFO-MTRTMP) (41A8h)**

Sets the condition under which the information is generated.

Index	Sub	Type	Access	PDO	Save	Initial value	Range	Update
41A8h	00h	INT16	RW	RxPDO	○	85	40 to 120 °C	A

● **Overvoltage information (INFO-OVOLT) (41A9h)**

Sets the condition under which the information is generated.

Index	Sub	Type	Access	PDO	Save	Initial value	Range	Update
41A9h	00h	INT16	RW	RxPDO	○	400	120 to 450 V	A

● **Undervoltage information (INFO-UVOLT) (41AAh)**

Sets the condition under which the information is generated.

Index	Sub	Type	Access	PDO	Save	Initial value	Range	Update
41AAh	00h	INT16	RW	RxPDO	○	120	120 to 280 V	A

● **Tripmeter information (INFO-TRIP) (41AFh)**

Sets the condition under which the information is generated.

Index	Sub	Type	Access	PDO	Save	Initial value	Range	Update
41AFh	00h	INT32	RW	RxPDO	○	0	0: Disable 1 to 2,147,483,647 (1=0.1 kRev)	A

● **Odometer information (INFO-ODO) (41B0h)**

Sets the condition under which the information is generated.

Index	Sub	Type	Access	PDO	Save	Initial value	Range	Update
41B0h	00h	INT32	RW	RxPDO	○	0	0: Disable 1 to 2,147,483,647 (1=0.1 kRev)	A

- **Cumulative load 0 information (INFO-CULD0) (41B1h)**

Sets the condition under which the information is generated.

Index	Sub	Type	Access	PDO	Save	Initial value	Range	Update
41B1h	00h	INT32	RW	RxPDO	○	0	0 to 2,147,483,647	A

- **Cumulative load 1 information (INFO-CULD1) (41B2h)**

Sets the condition under which the information is generated.

Index	Sub	Type	Access	PDO	Save	Initial value	Range	Update
41B2h	00h	INT32	RW	RxPDO	○	0	0 to 2,147,483,647	A

- **Cumulative load value auto clear (41B3h)**

Clears the cumulative load when operation is started (at the ON edge of the MOVE output).

Index	Sub	Type	Access	PDO	Save	Initial value	Range	Update
41B3h	00h	U8	RW	No	○	1	0: Does not clear 1: Clear	A

- **Cumulative load value count divisor (41B4h)**

Sets the divisor of the cumulative load.

Index	Sub	Type	Access	PDO	Save	Initial value	Range	Update
41B4h	00h	U16	RW	No	○	1	1 to 32,767	A

- **Settling time information (INFO-STLTIME) (41B5h)**

Sets the condition under which the information is generated.

Index	Sub	Type	Access	PDO	Save	Initial value	Range	Update
41B5h	00h	U16	RW	RxPDO	○	0	0: Disable 1 to 10,000 ms	A

- **INFO-USRIO output selection (41BCh)**

Selects the output signal to be checked by the INFO-USRIO output.

Index	Sub	Type	Access	PDO	Save	Initial value	Range	Update
41BCh	00h	U8	RW	No	○	128	Output signals list → p.116	A

- **INFO-USRIO output inversion (41BDh)**

Sets the ON-OFF status of the INFO-USRIO output.

Index	Sub	Type	Access	PDO	Save	Initial value	Range	Update
41BDh	00h	U8	RW	No	○	0	0: Non invert 1: Invert	A

- **Information LED condition (41BEh)**

Sets the LED status when information is generated.

Index	Sub	Type	Access	PDO	Save	Initial value	Range	Update
41BEh	00h	U8	RW	No	○	1	0: The LED does not blink 1: The LED blinks	A

- **Information auto clear (41BFh)**

When the cause of information is eliminated, the INFO output and the bit output of the corresponding information are turned OFF automatically.

Index	Sub	Type	Access	PDO	Save	Initial value	Range	Update
41BFh	00h	U8	RW	No	○	1	0: Disable (not turned OFF automatically) 1: Enable (turned OFF automatically)	A

● **Motor rotation direction (41C2h)**

Sets the rotation direction of the motor output shaft.

Index	Sub	Type	Access	PDO	Save	Initial value	Range	Update
41C2h	00h	U8	RW	No	○	1	0: Positive side=Counterclockwise 1: Positive side=Clockwise 2: Positive side=Counterclockwise (the driver parameter is applied) 3: Positive side=Clockwise (the driver parameter is applied)	C

● **Software overtravel (41C3h)**

Sets the action when the software overtravel is detected.

Index	Sub	Type	Access	PDO	Save	Initial value	Range	Update
41C3h	00h	INT8	RW	No	○	3	-1: Disable 0: Immediate stop 1: Deceleration stop 2: Immediate stop with alarm 3: Deceleration stop with alarm	A

● **Preset position (41C6h)**

Sets the preset position.

Index	Sub	Type	Access	PDO	Save	Initial value	Range	Update
41C6h	00h	INT32	RW	No	○	0	-2,147,483,648 to 2,147,483,647 steps	A

● **Wrap (RND) setting (41C7h)**

Sets the wrap function.

Index	Sub	Type	Access	PDO	Save	Initial value	Range	Update
41C7h	00h	U8	RW	No	○	1	0: Disable 1: Enable	C

● **Initial coordinate generation & wrap setting range (41C9h)**

Sets the wrap range.

Index	Sub	Type	Access	PDO	Save	Initial value	Range	Update
41C9h	00h	INT32	RW	No	○	10	5 to 655,360 (1=0.1 rev)	C

● **Initial coordinate generation & wrap range offset ratio (41CBh)**

Sets the offset ratio of the wrap range.

Index	Sub	Type	Access	PDO	Save	Initial value	Range	Update
41CBh	00h	U16	RW	No	○	5,000	0 to 10,000 (1=0.01 %)	C

● **Initial coordinate generation & wrap range offset value (41CCh)**

Sets the offset amount of the wrap range.

Index	Sub	Type	Access	PDO	Save	Initial value	Range	Update
41CCh	00h	INT32	RW	No	○	0	-536,870,912 to 536,870,911 steps	C

● **The number of the RND-ZERO output in wrap range (41CDh)**

Sets the number of times to turn the RND-ZERO output ON in the wrap range.

Index	Sub	Type	Access	PDO	Save	Initial value	Range	Update
41CDh	00h	INT32	RW	No	○	1	1 to 536,870,911	C

- **Driver simulation mode (41FFh)**

Situation for coordinates or I/O can be simulated using a virtual motor without connecting a motor.

Index	Sub	Type	Access	PDO	Save	Initial value	Range	Update
41FFh	00h	U8	RW	No	○	0	0: The motor is actually used 1: Virtual motor (when ABZO not connected=no ABZO information) 2: Virtual motor (when ABZO not connected=1,800 rev wrap enable) 3: Virtual motor (when ABZO not connected=900 rev wrap enable)	D

- **Touch probe 1 latch position (44B0h)**

Sets the position to latch by the external latch input (EXT1). The changed value is updated when the Touch probe 1 permission (60B8h: bit 0) is changed from 0 to 1.

Index	Sub	Type	Access	PDO	Save	Initial value	Range	Update
44B0h	00h	U8	RW	No	○	0	0: Latches the feedback position 1: Latches the command position	A

- **Touch probe 2 latch position (44B1h)**

Sets the position to latch by the external latch input (EXT2). The changed value is updated when the Touch probe 2 permission (60B8h: bit 8) is changed from 0 to 1.

Index	Sub	Type	Access	PDO	Save	Initial value	Range	Update
44B1h	00h	U8	RW	No	○	0	0: Latches the feedback position 1: Latches the command position	A

- **Information history 1 (4510h)**

This indicates the most recent item in the information history. When information is being generated, its code is also indicated on the information history 1 simultaneously.

Index	Sub	Name	Type	Access	PDO	Save	Initial value	Range	Update
4510h	00h	Information history 1	INT32	RO	No	–	–	–	–

- **Information history 2 to 15 (4511h to 451Eh)**

These indicate the items in the information history.

Index	Sub	Name	Type	Access	PDO	Save	Initial value	Range	Update
4511h	00h	Information history 2	INT32	RO	No	–	–	–	–
4512h	00h	Information history 3	INT32	RO	No	–	–	–	–
4513h	00h	Information history 4	INT32	RO	No	–	–	–	–
4514h	00h	Information history 5	INT32	RO	No	–	–	–	–
4515h	00h	Information history 6	INT32	RO	No	–	–	–	–
4516h	00h	Information history 7	INT32	RO	No	–	–	–	–
4517h	00h	Information history 8	INT32	RO	No	–	–	–	–
4518h	00h	Information history 9	INT32	RO	No	–	–	–	–
4519h	00h	Information history 10	INT32	RO	No	–	–	–	–
451Ah	00h	Information history 11	INT32	RO	No	–	–	–	–
451Bh	00h	Information history 12	INT32	RO	No	–	–	–	–
451Ch	00h	Information history 13	INT32	RO	No	–	–	–	–
451Dh	00h	Information history 14	INT32	RO	No	–	–	–	–
451Eh	00h	Information history 15	INT32	RO	No	–	–	–	–

- **Information history 16 (451Fh)**

This indicates the oldest item in the information history.

Index	Sub	Name	Type	Access	PDO	Save	Initial value	Range	Update
451Fh	00h	Information history 16	INT32	RO	No	–	–	–	–

● **Information time history 1 (4520h)**

This indicates the history item of the time when the most recent information was generated. When information is being generated, the generated time is also indicated on the information history 1 simultaneously.

Index	Sub	Name	Type	Access	PDO	Save	Initial value	Range	Update
4520h	00h	Information time history 1	INT32	RO	No	-	-	-	-

● **Information time history 2 to 15 (4521h to 452Eh)**

These indicate the history items of the time when the information was generated.

Index	Sub	Name	Type	Access	PDO	Save	Initial value	Range	Update
4521h	00h	Information time history 2	INT32	RO	No	-	-	-	-
4522h	00h	Information time history 3	INT32	RO	No	-	-	-	-
4523h	00h	Information time history 4	INT32	RO	No	-	-	-	-
4524h	00h	Information time history 5	INT32	RO	No	-	-	-	-
4525h	00h	Information time history 6	INT32	RO	No	-	-	-	-
4526h	00h	Information time history 7	INT32	RO	No	-	-	-	-
4527h	00h	Information time history 8	INT32	RO	No	-	-	-	-
4528h	00h	Information time history 9	INT32	RO	No	-	-	-	-
4529h	00h	Information time history 10	INT32	RO	No	-	-	-	-
452Ah	00h	Information time history 11	INT32	RO	No	-	-	-	-
452Bh	00h	Information time history 12	INT32	RO	No	-	-	-	-
452Ch	00h	Information time history 13	INT32	RO	No	-	-	-	-
452Dh	00h	Information time history 14	INT32	RO	No	-	-	-	-
452Eh	00h	Information time history 15	INT32	RO	No	-	-	-	-

● **Information time history 16 (452Fh)**

This indicates the history item of the time when the oldest information was generated.

Index	Sub	Name	Type	Access	PDO	Save	Initial value	Range	Update
452Fh	00h	Information time history 16	INT32	RO	No	-	-	-	-

● **FFT Value, FFT Frequency (45E0h to 45E7h)**

This indicate the result of the fast Fourier transform (FFT) analysis for the target set in the FFT target (49E2h).

Index	Sub	Name	Type	Access	PDO	Save	Initial value	Range	Update
45E0h	00h	FFT Value (1st peak)	U16	RO	No	-	-	-	-
45E1h	00h	FFT Frequency (1st peak)	U16	RO	No	-	-	-	-
45E2h	00h	FFT Value (2nd peak)	U16	RO	No	-	-	-	-
45E3h	00h	FFT Frequency (2nd peak)	U16	RO	No	-	-	-	-
45E4h	00h	FFT Value (3rd peak)	U16	RO	No	-	-	-	-
45E5h	00h	FFT Frequency (3rd peak)	U16	RO	No	-	-	-	-
45E6h	00h	FFT Value (4th peak)	U16	RO	No	-	-	-	-
45E7h	00h	FFT Frequency (4th peak)	U16	RO	No	-	-	-	-

● **Driver CPU number (4642h)**

This indicates the CPU number of the software of the driver.

Index	Sub	Type	Access	PDO	Save	Initial value	Range	Update
4642h	00h	U16	RO	No	-	-	-	-

● **Driver software version (4643h)**

This indicates the software version of the driver. "0100h" is indicated when the version is 1.00.

Index	Sub	Type	Access	PDO	Save	Initial value	Range	Update
4643h	00h	U16	RO	No	-	-	-	-

- **STOP input action (4700h)**

Sets how to stop the motor when the STOP input is turned ON.

Index	Sub	Type	Access	PDO	Save	Initial value	Range	Update
4700h	00h	INT8	RW	No	○	3	0: Immediate stop 3: Deceleration stop	A

- **FW-LS/RV-LS input action (4701h)**

Sets how to stop the motor when the FW-LS input or the RV-LS input is turned ON.

Index	Sub	Type	Access	PDO	Save	Initial value	Range	Update
4701h	00h	INT8	RW	No	○	2	-1: Used as a return-to-home sensor 0: Immediate stop 1: Deceleration stop 2: Immediate stop with alarm 3: Deceleration stop with alarm	A

- **FW-BLK/RV-BLK input action (4702h)**

Sets how to stop the motor when the FW-BLK input or the RV-BLK input is turned ON.

Index	Sub	Type	Access	PDO	Save	Initial value	Range	Update
4702h	00h	INT8	RW	No	○	0	0: Immediate stop 1: Deceleration stop	A

- **IN-POS positioning completion signal offset (4704h)**

Sets the amount of offset from the target position.

Index	Sub	Type	Access	PDO	Save	Initial value	Range	Update
4704h	00h	INT16	RW	No	○	0	-18 to 18 (1=0.1°)	A

- **ZSG signal width (4707h)**

Sets the output range of the ZSG output.

Index	Sub	Type	Access	PDO	Save	Initial value	Range	Update
4707h	00h	U16	RW	No	○	18	1 to 1,800 (1=0.1°)	A

- **RND-ZERO signal width (4708h)**

Sets the output width of the RND-ZERO output.

Index	Sub	Type	Access	PDO	Save	Initial value	Range	Update
4708h	00h	U16	RW	No	○	10	1 to 10,000 steps	A

- **RND-ZERO output data selection (4709h)**

Sets the criterion of the RND-ZERO output.

Index	Sub	Type	Access	PDO	Save	Initial value	Range	Update
4709h	00h	U8	RW	No	○	0	0: Based on feedback position 1: Based on command position	A

- **MOVE minimum ON time (470Ah)**

Sets the minimum time during which the MOVE output remains ON.

Index	Sub	Type	Access	PDO	Save	Initial value	Range	Update
470Ah	00h	U8	RW	No	○	0	0 to 255 ms	A

- **SPD-LMT speed limit type selection (470Eh)**

Selects the setting method of the speed limit value.

Index	Sub	Type	Access	PDO	Save	Initial value	Range	Update
470Eh	00h	INT8	RW	No	○	0	0: Ratio 1: Value	A

● **SPD-LMT speed limit ratio (470Fh)**

Sets the percentage of the speed limit based on "Operating speed" of the operation data being 100 %. This is enabled when the SPD-LMT speed limit type selection (470Eh) is set to "0: Ratio."

Index	Sub	Type	Access	PDO	Save	Initial value	Range	Update
470Fh	00h	INT8	RW	No	○	50	1 to 100 %	A

● **SPD-LMT speed limit value (4710h)**

Sets the speed limit value as "Value." This is enabled when the SPD-LMT speed limit type selection (470Eh) is set to "1: Value."

Index	Sub	Type	Access	PDO	Save	Initial value	Range	Update
4710h	00h	INT32	RW	No	○	10,000	1 to 4,000,000 Hz	A

● **VA mode selection (4718h)**

Selects the judgment criterion of the VA output.

Index	Sub	Type	Access	PDO	Save	Initial value	Range	Update
4718h	00h	U8	RW	No	○	2	0: Actual speed attainment (speed at feedback position) 1: Speed at command position (only internal profile) 2: Speed at feedback position & command position (only internal profile)	A

● **VA detection speed range (4719h)**

Sets the allowable range of the judgment criterion for the feedback speed when the VA mode selection (4718h) is set to "0: Actual speed attainment (speed at feedback position)" or "2: Speed at feedback position & command position (only internal profile)."

Index	Sub	Type	Access	PDO	Save	Initial value	Range	Update
4719h	00h	U8	RW	No	○	30	1 to 200 r/min	B

● **ZV detection speed range (471Dh)**

Sets the output range (one side) of the ZV output with the operating speed 0 as a center.

Index	Sub	Type	Access	PDO	Save	Initial value	Range	Update
471Dh	00h	U8	RW	No	○	15	0 to 200 r/min	A

- **AREA positive direction position/offset, AREA negative direction position/detection range (4740h to 474Fh)**

- AREA positive direction position/offset
Sets the positive direction position or offset from the target position for the AREA output.
- AREA negative direction position/offset
Sets the negative direction position or distance from the offset position for the AREA output.

Index	Sub	Name	Type	Access	PDO	Save	Initial value	Range	Update
4740h	00h	AREA0 positive direction position/offset	INT32	RW	No	<input type="radio"/>	0	-2,147,483,648 to 2,147,483,647 steps	A
4741h	00h	AREA0 negative direction position/detection range	INT32	RW	No	<input type="radio"/>	0		A
4742h	00h	AREA1 positive direction position/offset	INT32	RW	No	<input type="radio"/>	0		A
4743h	00h	AREA1 negative direction position/detection range	INT32	RW	No	<input type="radio"/>	0		A
4744h	00h	AREA2 positive direction position/offset	INT32	RW	No	<input type="radio"/>	0		A
4745h	00h	AREA2 negative direction position/detection range	INT32	RW	No	<input type="radio"/>	0		A
4746h	00h	AREA3 positive direction position/offset	INT32	RW	No	<input type="radio"/>	0		A
4747h	00h	AREA3 negative direction position/detection range	INT32	RW	No	<input type="radio"/>	0		A
4748h	00h	AREA4 positive direction position/offset	INT32	RW	No	<input type="radio"/>	0		A
4749h	00h	AREA4 negative direction position/detection range	INT32	RW	No	<input type="radio"/>	0		A
474Ah	00h	AREA5 positive direction position/offset	INT32	RW	No	<input type="radio"/>	0		A
474Bh	00h	AREA5 negative direction position/detection range	INT32	RW	No	<input type="radio"/>	0		A
474Ch	00h	AREA6 positive direction position/offset	INT32	RW	No	<input type="radio"/>	0		A
474Dh	00h	AREA6 negative direction position/detection range	INT32	RW	No	<input type="radio"/>	0		A
474Eh	00h	AREA7 positive direction position/offset	INT32	RW	No	<input type="radio"/>	0		A
474Fh	00h	AREA7 negative direction position/detection range	INT32	RW	No	<input type="radio"/>	0		A

- **AREA range setting mode (4750h to 4757h)**

Sets the range setting mode for the AREA output.

Index	Sub	Name	Type	Access	PDO	Save	Initial value	Range	Update
4750h	00h	AREA0 range setting mode	U8	RW	No	<input type="radio"/>	0	0: Range setting with absolute value 1: Offset/width setting from the target position	A
4751h	00h	AREA1 range setting mode	U8	RW	No	<input type="radio"/>	0		A
4752h	00h	AREA2 range setting mode	U8	RW	No	<input type="radio"/>	0		A
4753h	00h	AREA3 range setting mode	U8	RW	No	<input type="radio"/>	0		A
4754h	00h	AREA4 range setting mode	U8	RW	No	<input type="radio"/>	0		A
4755h	00h	AREA5 range setting mode	U8	RW	No	<input type="radio"/>	0		A
4756h	00h	AREA6 range setting mode	U8	RW	No	<input type="radio"/>	0		A
4757h	00h	AREA7 range setting mode	U8	RW	No	<input type="radio"/>	0		A

● **AREA positioning standard (4758h to 475Fh)**

Sets the judgment criterion of the position for the AREA output.

Index	Sub	Name	Type	Access	PDO	Save	Initial value	Range	Update
4758h	00h	AREA0 positioning standard	U8	RW	No	○	0	0: Based on feedback position 1: Based on command position	A
4759h	00h	AREA1 positioning standard	U8	RW	No	○	0		A
475Ah	00h	AREA2 positioning standard	U8	RW	No	○	0		A
475Bh	00h	AREA3 positioning standard	U8	RW	No	○	0		A
475Ch	00h	AREA4 positioning standard	U8	RW	No	○	0		A
475Dh	00h	AREA5 positioning standard	U8	RW	No	○	0		A
475Eh	00h	AREA6 positioning standard	U8	RW	No	○	0		A
475Fh	00h	AREA7 positioning standard	U8	RW	No	○	0		A

● **INFO action (47A0h to 47BFh)**

Sets the bit output, the INFO output, and the LED status when information is generated.

Index	Sub	Name	Type	Access	PDO	Save	Initial value	Range	Update
47A0h	00h	INFO action (Assigned I/O status information (INFO-USRIO))	U8	RW	No	○	1	0: Only the bit output is ON 1: The bit output and the INFO output are ON and the LED blinks	A
47A1h	00h	INFO action (Position deviation information (INFO-POSERR))	U8	RW	No	○	1		A
47A2h	00h	INFO action (Driver temperature information (INFO-DRVTMP))	U8	RW	No	○	1		A
47A3h	00h	INFO action (Motor temperature information (INFO-MTRTMP))	U8	RW	No	○	1		A
47A4h	00h	INFO action (Overvoltage information (INFO-OVOLT))	U8	RW	No	○	1		A
47A5h	00h	INFO action (Undervoltage information (INFO-UVOLT))	U8	RW	No	○	1		A
47A6h	00h	INFO action (Torque limiting time information (INFO-TLCTIME))	U8	RW	No	○	1		A
47A7h	00h	INFO action (Load factor information (INFO-LOAD))	U8	RW	No	○	1		A
47A8h	00h	INFO action (Speed information (INFO-SPD))	U8	RW	No	○	1		A
47A9h	00h	INFO action (Start operation error information (INFO-START))	U8	RW	No	○	1		A
47AAh	00h	INFO action (Start ZHOME error information (INFO-ZHOME))	U8	RW	No	○	1		A
47ABh	00h	INFO action (PRESET request information (INFO-PR-REQ))	U8	RW	No	○	1		A
47ADh	00h	INFO action (Electronic gear setting error information (INFO-EGR-E))	U8	RW	No	○	1		A
47AEh	00h	INFO action (Wrap setting error information (INFO-RND-E))	U8	RW	No	○	1		A
47B0h	00h	INFO action (Forward operation prohibition information (INFO-FW-OT))	U8	RW	No	○	1		A
47B1h	00h	INFO action (Reverse operation prohibition information (INFO-RV-OT))	U8	RW	No	○	1		A
47B2h	00h	INFO action (Cumulative load 0 information (INFO-CULDO))	U8	RW	No	○	1		A

Index	Sub	Name	Type	Access	PDO	Save	Initial value	Range	Update
47B3h	00h	INFO action (Cumulative load 1 information (INFO-CULD1))	U8	RW	No	<input type="radio"/>	1	0: Only the bit output is ON 1: The bit output and the INFO output are ON and the LED blinks	A
47B4h	00h	INFO action (Tripmeter information (INFO-TRIP))	U8	RW	No	<input type="radio"/>	1		A
47B5h	00h	INFO action (Odometer information (INFO-ODO))	U8	RW	No	<input type="radio"/>	1		A
47B7h	00h	INFO action (Torque information (INFO-TRQ))	U8	RW	No	<input type="radio"/>	1		A
47B8h	00h	INFO action (Settling time information (INFO-STLTIME))	U8	RW	No	<input type="radio"/>	1		A
47BCh	00h	INFO action (Start operation restricted mode information (INFO-DSLMTD))	U8	RW	No	<input type="radio"/>	1		A
47BDh	00h	INFO action (I/O test mode information (INFO-IOTEST))	U8	RW	No	<input type="radio"/>	1		A
47BEh	00h	INFO action (Configuration request information (INFO-CFG))	U8	RW	No	<input type="radio"/>	1		A
47BFh	00h	INFO action (Reboot request information (INFO-RBT))	U8	RW	No	<input type="radio"/>	1		A

● Mechanism settings (47F0h)

To change the mechanism settings parameter, select "Manual setting."

Index	Sub	Type	Access	PDO	Save	Initial value	Range	Update
47F0h	00h	U8	RW	No	<input type="radio"/>	1	0: Prioritize ABZO setting 1: Manual setting	D

● Gear ratio setting (47F1h)

Sets the gear ratio for geared motor. When "0: Gear ratio setting disable" is set, the gear ratio is considered as "1."

Index	Sub	Type	Access	PDO	Save	Initial value	Range	Update
47F1h	00h	INT16	RW	No	<input type="radio"/>	0	0: Gear ratio setting disable 1 to 32,767: Gear ratio (1=0.01)	C

● Initial coordinate generation & wrap coordinate setting (47F2h)

To change the initial coordinate generation & wrap coordinate parameter, select "Manual setting."

Index	Sub	Type	Access	PDO	Save	Initial value	Range	Update
47F2h	00h	U8	RW	No	<input type="radio"/>	0	0: Prioritize ABZO setting 1: Manual setting	D

● Mechanism limit parameter setting (47F3h)

Disables the ABZO setting of the mechanism limit parameter.

Index	Sub	Type	Access	PDO	Save	Initial value	Range	Update
47F3h	00h	U8	RW	No	<input type="radio"/>	0	0: Follow ABZO setting 1: Disable	D

● Mechanism protection parameter setting (47F4h)

Disables the ABZO setting of the mechanism protection parameter.

Index	Sub	Type	Access	PDO	Save	Initial value	Range	Update
47F4h	00h	U8	RW	No	<input type="radio"/>	0	0: Follow ABZO setting 1: Disable	D

● **JOG/HOME/ZHOME operation setting (47F5h)**

To change the parameter for JOG operation, return-to-home operation, and high-speed return-to-home operation, select "Manual setting."

Index	Sub	Type	Access	PDO	Save	Initial value	Range	Update
47F5h	00h	U8	RW	No	○	0	0: Prioritize ABZO setting 1: Manual setting	D

● **Damping control frequency (4810h)**

Sets the frequency of vibration to be suppressed.

Index	Sub	Type	Access	PDO	Save	Initial value	Range	Update
4810h	00h	U16	RW	No	○	10,000	700 to 20,000 (1=0.01 Hz)	A

● **Damping control gain (4811h)**

Sets the gain for damping control (vibration suppression control).

Index	Sub	Type	Access	PDO	Save	Initial value	Range	Update
4811h	00h	INT8	RW	No	○	0	0 to 100 %	A

● **Resonance suppression control frequency**

Sets the frequency of vibration to be suppressed.

Index	Sub	Name	Type	Access	PDO	Save	Initial value	Range	Update
4813h	00h	Resonance suppression control A frequency	INT16	RW	No	○	1,000	100 to 3,200 Hz	A
4816h	00h	Resonance suppression control B frequency	INT16	RW	No	○	1,000		A
4819h	00h	Resonance suppression control C frequency	INT16	RW	No	○	1,000		A
481Ch	00h	Resonance suppression control D frequency	INT16	RW	No	○	1,000		A

● **Resonance suppression control gain**

Sets the gain to suppress the vibration. Increasing the value causes the motor response to the deviation to lower.

Index	Sub	Name	Type	Access	PDO	Save	Initial value	Range	Update
4814h	00h	Resonance suppression control A gain	INT8	RW	No	○	0	0 to 100 %	A
4817h	00h	Resonance suppression control B gain	INT8	RW	No	○	0		A
481Ah	00h	Resonance suppression control C gain	INT8	RW	No	○	0		A
481Dh	00h	Resonance suppression control D gain	INT8	RW	No	○	0		A

● **Resonance suppression control width**

Sets the width of vibration to be suppressed.

Index	Sub	Name	Type	Access	PDO	Save	Initial value	Range	Update
4815h	00h	Resonance suppression control A width	U8	RW	No	○	30	30 to 120	A
4818h	00h	Resonance suppression control B width	U8	RW	No	○	30		A
481Bh	00h	Resonance suppression control C width	U8	RW	No	○	30		A
481Eh	00h	Resonance suppression control D width	U8	RW	No	○	30		A

- **DIN input function (4840h to 4845h)**

Selects an input signal to be assigned to DIN.

Index	Sub	Name	Type	Access	PDO	Save	Initial value	Range	Update
4840h	00h	DIN0 input function	U8	RW	No	<input type="radio"/>	30	Input signals list ⇒ p.115	C
4841h	00h	DIN1 input function	U8	RW	No	<input type="radio"/>	1		C
4842h	00h	DIN2 input function	U8	RW	No	<input type="radio"/>	12		C
4843h	00h	DIN3 input function	U8	RW	No	<input type="radio"/>	104		C
4844h	00h	DIN4 input function	U8	RW	No	<input type="radio"/>	28		C
4845h	00h	DIN5 input function	U8	RW	No	<input type="radio"/>	29		C

- **DIN inverting mode (4850h to 4855h)**

Changes the ON-OFF setting of DIN.

Index	Sub	Name	Type	Access	PDO	Save	Initial value	Range	Update
4850h	00h	DIN0 inverting mode	U8	RW	No	<input type="radio"/>	0	0: Non invert 1: Invert	C
4851h	00h	DIN1 inverting mode	U8	RW	No	<input type="radio"/>	0		C
4852h	00h	DIN2 inverting mode	U8	RW	No	<input type="radio"/>	0		C
4853h	00h	DIN3 inverting mode	U8	RW	No	<input type="radio"/>	0		C
4854h	00h	DIN4 inverting mode	U8	RW	No	<input type="radio"/>	0		C
4855h	00h	DIN5 inverting mode	U8	RW	No	<input type="radio"/>	0		C

- **DOUT (Normal) output function (4860h to 4865h)**

Selects an output signal to be assigned to DOUT.

Index	Sub	Name	Type	Access	PDO	Save	Initial value	Range	Update
4860h	00h	DOUT0 (Normal) output function	U8	RW	No	<input type="radio"/>	144	Output signals list ⇒ p.116	C
4861h	00h	DOUT1 (Normal) output function	U8	RW	No	<input type="radio"/>	137		C
4862h	00h	DOUT2 (Normal) output function	U8	RW	No	<input type="radio"/>	0		C
4863h	00h	DOUT3 (Normal) output function	U8	RW	No	<input type="radio"/>	142		C
4864h	00h	DOUT4 (Normal) output function	U8	RW	No	<input type="radio"/>	134		C
4865h	00h	DOUT5 (Normal) output function	U8	RW	No	<input type="radio"/>	130		C

- **DOUT inverting mode (4870h to 4875h)**

Changes the ON-OFF setting of DOUT.

Index	Sub	Name	Type	Access	PDO	Save	Initial value	Range	Update
4870h	00h	DOUT0 inverting mode	U8	RW	No	<input type="radio"/>	0	0: Non invert 1: Invert	C
4871h	00h	DOUT1 inverting mode	U8	RW	No	<input type="radio"/>	0		C
4872h	00h	DOUT2 inverting mode	U8	RW	No	<input type="radio"/>	0		C
4873h	00h	DOUT3 inverting mode	U8	RW	No	<input type="radio"/>	0		C
4874h	00h	DOUT4 inverting mode	U8	RW	No	<input type="radio"/>	0		C
4875h	00h	DOUT5 inverting mode	U8	RW	No	<input type="radio"/>	0		C

● **DIN composite input function (4880h to 4885h)**

Selects an input signal to be assigned to DIN as the composite input function.

Index	Sub	Name	Type	Access	PDO	Save	Initial value	Range	Update
4880h	00h	DIN0 composite input function	U8	RW	No	○	0	Input signals list ⇒ p.115	C
4881h	00h	DIN1 composite input function	U8	RW	No	○	0		C
4882h	00h	DIN2 composite input function	U8	RW	No	○	0		C
4883h	00h	DIN3 composite input function	U8	RW	No	○	0		C
4884h	00h	DIN4 composite input function	U8	RW	No	○	0		C
4885h	00h	DIN5 composite input function	U8	RW	No	○	0		C

● **DOUT0 composite output function (4890h to 4895h)**

Selects an output signal for logical operation with the signal of DOUT.

Index	Sub	Name	Type	Access	PDO	Save	Initial value	Range	Update
4890h	00h	DOUT0 composite output function	U8	RW	No	○	128	Output signals list ⇒ p.116	C
4891h	00h	DOUT1 composite output function	U8	RW	No	○	128		C
4892h	00h	DOUT2 composite output function	U8	RW	No	○	128		C
4893h	00h	DOUT3 composite output function	U8	RW	No	○	128		C
4894h	00h	DOUT4 composite output function	U8	RW	No	○	128		C
4895h	00h	DOUT5 composite output function	U8	RW	No	○	128		C

● **DOUT composite inverting mode (48A0h to 48A5h)**

Changes the ON-OFF setting of the composite output function of DOUT.

Index	Sub	Name	Type	Access	PDO	Save	Initial value	Range	Update
48A0h	00h	DOUT0 composite inverting mode	U8	RW	No	○	0	0: Non invert 1: Invert	C
48A1h	00h	DOUT1 composite inverting mode	U8	RW	No	○	0		C
48A2h	00h	DOUT2 composite inverting mode	U8	RW	No	○	0		C
48A3h	00h	DOUT3 composite inverting mode	U8	RW	No	○	0		C
48A4h	00h	DOUT4 composite inverting mode	U8	RW	No	○	0		C
48A5h	00h	DOUT5 composite inverting mode	U8	RW	No	○	0		C

- **DOUT composite logical combination (48B0h to 48B5h)**

Sets the composite logical combination of DOUT.

Index	Sub	Name	Type	Access	PDO	Save	Initial value	Range	Update
48B0h	00h	DOUT0 composite logical combination	U8	RW	No	○	1	0: AND 1: OR	C
48B1h	00h	DOUT1 composite logical combination	U8	RW	No	○	1		C
48B2h	00h	DOUT2 composite logical combination	U8	RW	No	○	1		C
48B3h	00h	DOUT3 composite logical combination	U8	RW	No	○	1		C
48B4h	00h	DOUT4 composite logical combination	U8	RW	No	○	1		C
48B5h	00h	DOUT5 composite logical combination	U8	RW	No	○	1		C

- **DIN ON signal dead-time (48C0h to 48C5h)**

Sets the ON signal dead-time of DIN.

Index	Sub	Name	Type	Access	PDO	Save	Initial value	Range	Update
48C0h	00h	DIN0 ON signal dead-time	U8	RW	No	○	0	0 to 250 ms	C
48C1h	00h	DIN1 ON signal dead-time	U8	RW	No	○	0		C
48C2h	00h	DIN2 ON signal dead-time	U8	RW	No	○	0		C
48C3h	00h	DIN3 ON signal dead-time	U8	RW	No	○	0		C
48C4h	00h	DIN4 ON signal dead-time	U8	RW	No	○	0		C
48C5h	00h	DIN5 ON signal dead-time	U8	RW	No	○	0		C

- **DIN 1 shot signal (48D0h to 48D5h)**

Sets the 1-shot signal function of DIN.

Index	Sub	Name	Type	Access	PDO	Save	Initial value	Range	Update
48D0h	00h	DIN0 1 shot signal	U8	RW	No	○	0	0: Disable 1: Enable	C
48D1h	00h	DIN1 1 shot signal	U8	RW	No	○	0		C
48D2h	00h	DIN2 1 shot signal	U8	RW	No	○	0		C
48D3h	00h	DIN3 1 shot signal	U8	RW	No	○	0		C
48D4h	00h	DIN4 1 shot signal	U8	RW	No	○	0		C
48D5h	00h	DIN5 1 shot signal	U8	RW	No	○	0		C

- **DOUT OFF delay time (48E0h to 48E5h)**

Sets the OFF delay time of DOUT.

Index	Sub	Name	Type	Access	PDO	Save	Initial value	Range	Update
48E0h	00h	DOUT0 OFF delay time	U8	RW	No	○	0	0 to 250 ms	C
48E1h	00h	DOUT1 OFF delay time	U8	RW	No	○	0		C
48E2h	00h	DOUT2 OFF delay time	U8	RW	No	○	0		C
48E3h	00h	DOUT3 OFF delay time	U8	RW	No	○	0		C
48E4h	00h	DOUT4 OFF delay time	U8	RW	No	○	0		C
48E5h	00h	DOUT5 OFF delay time	U8	RW	No	○	0		

● **R-IN input function (4900h to 490Fh)**

Selects an input signal to be assigned to R-IN.

Index	Sub	Name	Type	Access	PDO	Save	Initial value	Range	Update
4900h	00h	R-IN0 input function	U8	RW	No	○	0	Input signals list ⇒ p.115	C
4901h	00h	R-IN1 input function	U8	RW	No	○	0		C
4902h	00h	R-IN2 input function	U8	RW	No	○	0		C
4903h	00h	R-IN3 input function	U8	RW	No	○	0		C
4904h	00h	R-IN4 input function	U8	RW	No	○	0		C
4905h	00h	R-IN5 input function	U8	RW	No	○	0		C
4906h	00h	R-IN6 input function	U8	RW	No	○	0		C
4907h	00h	R-IN7 input function	U8	RW	No	○	0		C
4908h	00h	R-IN8 input function	U8	RW	No	○	0		C
4909h	00h	R-IN9 input function	U8	RW	No	○	0		C
490Ah	00h	R-IN10 input function	U8	RW	No	○	0		C
490Bh	00h	R-IN11 input function	U8	RW	No	○	0		C
490Ch	00h	R-IN12 input function	U8	RW	No	○	0		C
490Dh	00h	R-IN13 input function	U8	RW	No	○	0		C
490Eh	00h	R-IN14 input function	U8	RW	No	○	0		C
490Fh	00h	R-IN15 input function	U8	RW	No	○	0		C

● **R-OUT output function (4910h to 491Fh)**

Selects an output signal to be assigned to R-OUT.

Index	Sub	Name	Type	Access	PDO	Save	Initial value	Range	Update
4910h	00h	R-OUT0 output function	U8	RW	No	○	28	Output signals list ⇒ p.116	C
4911h	00h	R-OUT1 output function	U8	RW	No	○	29		C
4912h	00h	R-OUT2 output function	U8	RW	No	○	155		C
4913h	00h	R-OUT3 output function	U8	RW	No	○	0		C
4914h	00h	R-OUT4 output function	U8	RW	No	○	144		C
4915h	00h	R-OUT5 output function	U8	RW	No	○	204		C
4916h	00h	R-OUT6 output function	U8	RW	No	○	135		C
4917h	00h	R-OUT7 output function	U8	RW	No	○	129		C
4918h	00h	R-OUT8 output function	U8	RW	No	○	136		C
4919h	00h	R-OUT9 output function	U8	RW	No	○	160		C
491Ah	00h	R-OUT10 output function	U8	RW	No	○	161		C
491Bh	00h	R-OUT11 output function	U8	RW	No	○	162		C
491Ch	00h	R-OUT12 output function	U8	RW	No	○	0		C
491Dh	00h	R-OUT13 output function	U8	RW	No	○	134		C
491Eh	00h	R-OUT14 output function	U8	RW	No	○	138		C
491Fh	00h	R-OUT15 output function	U8	RW	No	○	140		C

- **R-OUT OFF delay time (4930h to 493Fh)**

Sets the OFF delay time of R-OUT.

Index	Sub	Name	Type	Access	PDO	Save	Initial value	Range	Update
4930h	00h	R-OUT0 OFF delay time	U8	RW	No	<input type="radio"/>	0	0 to 250 ms	C
4931h	00h	R-OUT1 OFF delay time	U8	RW	No	<input type="radio"/>	0		C
4932h	00h	R-OUT2 OFF delay time	U8	RW	No	<input type="radio"/>	0		C
4933h	00h	R-OUT3 OFF delay time	U8	RW	No	<input type="radio"/>	0		C
4934h	00h	R-OUT4 OFF delay time	U8	RW	No	<input type="radio"/>	0		C
4935h	00h	R-OUT5 OFF delay time	U8	RW	No	<input type="radio"/>	0		C
4936h	00h	R-OUT6 OFF delay time	U8	RW	No	<input type="radio"/>	0		C
4937h	00h	R-OUT7 OFF delay time	U8	RW	No	<input type="radio"/>	0		C
4938h	00h	R-OUT8 OFF delay time	U8	RW	No	<input type="radio"/>	0		C
4939h	00h	R-OUT9 OFF delay time	U8	RW	No	<input type="radio"/>	0		C
493Ah	00h	R-OUT10 OFF delay time	U8	RW	No	<input type="radio"/>	0		C
493Bh	00h	R-OUT11 OFF delay time	U8	RW	No	<input type="radio"/>	0		C
493Ch	00h	R-OUT12 OFF delay time	U8	RW	No	<input type="radio"/>	0		C
493Dh	00h	R-OUT13 OFF delay time	U8	RW	No	<input type="radio"/>	0		C
493Eh	00h	R-OUT14 OFF delay time	U8	RW	No	<input type="radio"/>	0		C
493Fh	00h	R-OUT15 OFF delay time	U8	RW	No	<input type="radio"/>	0		C

- **Virtual input (VIR-IN) function (4940h to 4943h)**

Selects an input signal to be assigned to VIR-IN.

Index	Sub	Name	Type	Access	PDO	Save	Initial value	Range	Update
4940h	00h	Virtual input (VIR-IN0) function	U8	RW	No	<input type="radio"/>	0	Input signals list ⇒ p.115	C
4941h	00h	Virtual input (VIR-IN1) function	U8	RW	No	<input type="radio"/>	0		C
4942h	00h	Virtual input (VIR-IN2) function	U8	RW	No	<input type="radio"/>	0		C
4943h	00h	Virtual input (VIR-IN3) function	U8	RW	No	<input type="radio"/>	0		C

- **Virtual input (VIR-IN) source selection (4944h to 4947h)**

Selects an output signal to be the trigger of VIR-IN.

Index	Sub	Name	Type	Access	PDO	Save	Initial value	Range	Update
4944h	00h	Virtual input (VIR-IN0) source selection	U8	RW	No	<input type="radio"/>	128	Output signals list ⇒ p.116	C
4945h	00h	Virtual input (VIR-IN1) source selection	U8	RW	No	<input type="radio"/>	128		C
4946h	00h	Virtual input (VIR-IN2) source selection	U8	RW	No	<input type="radio"/>	128		C
4947h	00h	Virtual input (VIR-IN3) source selection	U8	RW	No	<input type="radio"/>	128		C

● **Virtual input (VIR-IN) inverting mode (4948h to 494Bh)**

Changes the ON-OFF setting of VIR-IN.

Index	Sub	Name	Type	Access	PDO	Save	Initial value	Range	Update
4948h	00h	Virtual input (VIR-IN0) inverting mode	U8	RW	No	○	0	0: Non invert 1: Invert	C
4949h	00h	Virtual input (VIR-IN1) inverting mode	U8	RW	No	○	0		C
494Ah	00h	Virtual input (VIR-IN2) inverting mode	U8	RW	No	○	0		C
494Bh	00h	Virtual input (VIR-IN3) inverting mode	U8	RW	No	○	0		C

● **Virtual input (VIR-IN) ON signal dead-time (494Ch to 494Fh)**

Sets the ON signal dead-time of VIR-IN.

Index	Sub	Name	Type	Access	PDO	Save	Initial value	Range	Update
494Ch	00h	Virtual input (VIR-IN0) ON signal dead time	U8	RW	No	○	0	0 to 250 ms	C
494Dh	00h	Virtual input (VIR-IN1) ON signal dead time	U8	RW	No	○	0		C
494Eh	00h	Virtual input (VIR-IN2) ON signal dead time	U8	RW	No	○	0		C
494Fh	00h	Virtual input (VIR-IN3) ON signal dead time	U8	RW	No	○	0		C

● **Virtual input (VIR-IN) 1 shot signal mode (4950h to 4953h)**

Enables the 1-shot signal function of VIR-IN.

Index	Sub	Name	Type	Access	PDO	Save	Initial value	Range	Update
4950h	00h	Virtual input (VIR-IN0) 1 shot signal mode	U8	RW	No	○	0	0: Disable 1: Enable	C
4951h	00h	Virtual input (VIR-IN1) 1 shot signal mode	U8	RW	No	○	0		C
4952h	00h	Virtual input (VIR-IN2) 1 shot signal mode	U8	RW	No	○	0		C
4953h	00h	Virtual input (VIR-IN3) 1 shot signal mode	U8	RW	No	○	0		C

● **User output (USR-OUT) source A function (4960h, 4961h)**

Sets the output source A of USR-OUT.

Index	Sub	Name	Type	Access	PDO	Save	Initial value	Range	Update
4960h	00h	User output (USR-OUT0) source A function	U8	RW	No	○	128	Output signals list ⇒ p.116	C
4961h	00h	User output (USR-OUT1) source A function	U8	RW	No	○	128		C

● **User output (USR-OUT) source A inverting mode (4962h, 4963h)**

Changes the ON/OFF setting of the output source A of USR-OUT.

Index	Sub	Name	Type	Access	PDO	Save	Initial value	Range	Update
4962h	00h	User output (USR-OUT0) source A inverting mode	U8	RW	No	○	0	0: Non invert 1: Invert	C
4963h	00h	User output (USR-OUT1) source A inverting mode	U8	RW	No	○	0		C

- **User output (USR-OUT) source B function (4964h, 4965h)**

Sets the output source B of USR-OUT.

Index	Sub	Name	Type	Access	PDO	Save	Initial value	Range	Update
4964h	00h	User output (USR-OUT0) source B function	U8	RW	No	○	128	Output signals list ⇒ p.116	C
4965h	00h	User output (USR-OUT1) source B function	U8	RW	No	○	128		C

- **User output (USR-OUT) source B inverting mode (4966h, 4967h)**

Changes the ON/OFF setting of the output source B of USR-OUT.

Index	Sub	Name	Type	Access	PDO	Save	Initial value	Range	Update
4966h	00h	User output (USR-OUT0) source B inverting mode	U8	RW	No	○	0	0: Non invert 1: Invert	C
4967h	00h	User output (USR-OUT1) source B inverting mode	U8	RW	No	○	0		C

- **User output (USR-OUT) logical operation (4968h, 4969h)**

Sets the logical combination of the user output sources A and B of USR-OUT.

Index	Sub	Name	Type	Access	PDO	Save	Initial value	Range	Update
4968h	00h	User output (USR-OUT0) logical operation	U8	RW	No	○	1	0: AND 1: OR	C
4969h	00h	User output (USR-OUT1) logical operation	U8	RW	No	○	1		C

- **Extended input (EXT-IN) function (4970h)**

Selects an input signal to be assigned to the HOME PRESET switch.

Index	Sub	Type	Access	PDO	Save	Initial value	Range	Update
4970h	00h	U8	RW	No	○	9	Input signals list ⇒ p.115	C

- **Extended input (EXT-IN) inverting mode (4971h)**

Changes the ON-OFF setting of the input signal to be assigned to the HOME PRESET switch.

Index	Sub	Type	Access	PDO	Save	Initial value	Range	Update
4971h	00h	U8	RW	No	○	0	0: Non invert 1: Invert	C

- **Extended input (EXT-IN) interlock releasing time (4972h)**

Normally, the HOME PRESET switch is interlocked. Pressing and holding the switch for a certain amount of time will release the interlock and enable the assigned function. This parameter is used to set the amount of time that the switch must be pressed and held down in order to release the interlock.

Index	Sub	Type	Access	PDO	Save	Initial value	Range	Update
4972h	00h	INT8	RW	No	○	10	0: Disable 1 to 50 (1=0.1 s)	A

- **Extended input (EXT-IN) interlock releasing duration (4973h)**

Sets the amount of time that the state of releasing the interlock is maintained.

Index	Sub	Type	Access	PDO	Save	Initial value	Range	Update
4973h	00h	INT8	RW	No	○	30	0 to 50 (1=0.1 s)	A

- **Extended input (EXT-IN) ON monitor time (4974h)**

When a signal assigned to the switch is input, the LED is lit. This parameter is used to set the amount of time that the LED is lit.

Index	Sub	Type	Access	PDO	Save	Initial value	Range	Update
4974h	00h	INT8	RW	No	○	10	0 to 50 (1=0.1 s)	A

● **FFT target (49E2h)**

Selects the target to be analyzed by the fast Fourier transform (FFT).

Index	Sub	Type	Access	PDO	Save	Initial value	Range	Update
49E2h	00h	INT8	RW	No	○	0	0: Torque 1: Speed	A

4-2 Object list

Index	Sub	Name	Type	Access	PDO	Save	Initial value	Range	Update
4020h	00h	Backup DATA access key	INT32	RW	No	–	0	Key code: 20519253 (01391955h)	A
4021h	00h	Backup DATA write key	INT32	RW	No	–	0	Key code: 1977326743 (75DB9C97h)	A
403Eh	00h	Driver input command	U16	RW	RxPDO	–	0	0000h to FFFFh	A
403Fh	00h	Driver output status	U16	RO	TxPDO	–	–		
4040h	00h	Present alarm	U16	RO	TxPDO	–	–		
4041h	00h	Alarm history 1	U16	RO	No	–	–		
4042h	00h	Alarm history 2	U16	RO	No	–	–		
4043h	00h	Alarm history 3	U16	RO	No	–	–		
4044h	00h	Alarm history 4	U16	RO	No	–	–		
4045h	00h	Alarm history 5	U16	RO	No	–	–		
4046h	00h	Alarm history 6	U16	RO	No	–	–		
4047h	00h	Alarm history 7	U16	RO	No	–	–		
4048h	00h	Alarm history 8	U16	RO	No	–	–		
4049h	00h	Alarm history 9	U16	RO	No	–	–		
404Ah	00h	Alarm history 10	U16	RO	No	–	–		
4064h	00h	Command speed [r/min]	INT32	RO	TxPDO	–	–		
4067h	00h	Feedback speed [r/min]	INT32	RO	TxPDO	–	–		
406Ah	00h	Direct I/O	U32	RO	TxPDO	–	–		
406Bh	00h	Torque monitor [1=0.1 %]	INT16	RO	TxPDO	–	–		
406Ch	00h	Load factor monitor [1=0.1 %]	INT16	RO	TxPDO	–	–		
406Dh	00h	Cumulative Load Monitor	INT32	RO	TxPDO	–	–		
406Eh	00h	Torque limiting value [1=0.1 %]	INT16	RO	TxPDO	–	–	–	–
407Bh	00h	Present information	INT32	RO	TxPDO	–	–		
407Ch	00h	Driver temperature [1=0.1 °C]	INT16	RO	TxPDO	–	–		
407Dh	00h	Motor temperature [1=0.1 °C]	INT16	RO	TxPDO	–	–		
407Eh	00h	Odometer [1=0.1 kRev]	INT32	RO	TxPDO	–	–		
407Fh	00h	Tripmeter [1=0.1 kRev]	INT32	RO	TxPDO	–	–		
4090h	00h	Feedback position 32-bit counter	INT32	RO	TxPDO	–	–		
4091h	00h	Command position 32-bit counter	INT32	RO	TxPDO	–	–		
4096h	00h	Settling time [ms]	INT32	RO	TxPDO	–	–		
40A0h	00h	Main power supply count	INT32	RO	TxPDO	–	–		
40A1h	00h	Main power supply time [min]	INT32	RO	TxPDO	–	–		
40A2h	00h	Control power supply count	INT32	RO	TxPDO	–	–		
40A3h	00h	Inverter voltage [1=0.1 V]	INT16	RO	TxPDO	–	–		
40A9h	00h	Elapsed time from BOOT [ms]	INT32	RO	TxPDO	–	–		
40B8h	00h	I/O status 1	U32	RO	TxPDO	–	–		
40B9h	00h	I/O status 2	U32	RO	TxPDO	–	–		
40BAh	00h	I/O status 3	U32	RO	TxPDO	–	–		
40BBh	00h	I/O status 4	U32	RO	TxPDO	–	–		

Index	Sub	Name	Type	Access	PDO	Save	Initial value	Range	Update
40BCh	00h	I/O status 5	U32	RO	TxPDO	–	–	–	–
40BDh	00h	I/O status 6	U32	RO	TxPDO	–	–		
40BEh	00h	I/O status 7	U32	RO	TxPDO	–	–		
40BFh	00h	I/O status 8	U32	RO	TxPDO	–	–		
40C0h	00h	Alarm reset	U8	RW	No	–	0	0: Not executed. 1: A command is executed when the data changes from 0 to 1. 2: A command is executed. It will automatically return to 1 after executing.	–
40C2h	00h	Clear alarm history	U8	RW	No	–	0		
40C5h	00h	P-PRESET execution	U8	RW	No	–	0		
40C6h	00h	Configuration	U8	RW	No	–	0		
40C8h	00h	Read batch NV memory	U8	RW	No	–	0		
40C9h	00h	Write batch NV memory	U8	RW	No	–	0		
40CAh	00h	All data batch initialization	U8	RW	No	–	0		
40CBh	00h	Read from backup	U8	RW	No	–	0		
40CCh	00h	Write to backup	U8	RW	No	–	0		
40CDh	00h	Clear latch information	U8	RW	No	–	0		
40CFh	00h	Clear tripmeter	U8	RW	No	–	0		
40D0h	00h	Execute ETO-CLR input	U8	RW	No	–	0		
40D1h	00h	ZSG-PRESET	U8	RW	No	–	0		
40D2h	00h	Clear ZSG-PRESET	U8	RW	No	–	0		
40D3h	00h	Clear information	U8	RW	No	–	0		
40D4h	00h	Clear information history	U8	RW	No	–	0		
4120h	00h	Load inertia setting mode selection	INT8	RW	No	○	1	0: Load inertia setting (4121h) is used 1: Automatic	A
4121h	00h	Load inertia setting	INT16	RW	No	○	0	0 to 10,000 %	A
4124h	00h	Mechanical rigidity setting	INT8	RW	No	○	6	0 to 15	A
4129h	00h	Command filter setting	INT8	RW	No	○	1	1: LPF (speed filter) 2: Moving average filter	B
412Ah	00h	Command filter time constant	INT16	RW	RxPDO	○	1	0 to 200 ms	B
412Eh	00h	Motor response setting	INT8	RW	No	○	6	–1: Manual setting 0 to 15	A
412Fh	00h	Position loop gain	INT16	RW	No	○	8	1 to 50 Hz	A
4130h	00h	Speed loop gain	INT16	RW	No	○	82	1 to 500 Hz	A
4131h	00h	Speed loop integral time constant	INT16	RW	No	○	1,940	1 to 10,000 (1=0.01 ms)	A
4136h	00h	Electronic damper function	INT8	RW	No	○	1	0: Disable 1: Enable	A
413Ah	00h	Torque filter (LPF)	INT16	RW	No	○	820	0 to 4,700 Hz	A
413Bh	00h	Speed feed-forward	U8	RW	No	○	80	0 to 100 %	A
4142h	00h	Starting speed	INT32	RW	No	○	5,000	0 to 4,000,000 Hz	B
4148h	00h	Permission of absolute positioning without setting absolute coordinates	U8	RW	No	○	0	0: Disable 1: Enable	B
414Ch	00h	Operation selection after stopping in speed control mode	U8	RW	No	○	0	0: Position loop disable 1: Position loop enable	B
414Fh	00h	Wrap positioning mode	U8	RW	RxPDO	○	0	0: Wrap absolute positioning 1: Wrap proximity 2: Wrap forward direction 3: Wrap reverse direction	B
4151h	00h	(JOG) Operating speed	INT32	RW	No	○	10,000	1 to 4,000,000 Hz	B
4152h	00h	(JOG) Acceleration/ deceleration	INT32	RW	No	○	300,000	1 to 1,000,000,000 kHz/s	B
4153h	00h	(JOG) Starting speed	INT32	RW	No	○	5,000	0 to 4,000,000 Hz	B
4154h	00h	(JOG) Operating speed (high)	INT32	RW	No	○	50,000	1 to 4,000,000 Hz	B
4158h	00h	(ZHOME) Operating speed	INT32	RW	No	○	50,000	1 to 4,000,000 Hz	B

Index	Sub	Name	Type	Access	PDO	Save	Initial value	Range	Update
4159h	00h	(ZHOME) Acceleration/ deceleration	INT32	RW	No	○	300,000	1 to 1,000,000,000 kHz/s	B
415Ah	00h	(ZHOME) Starting speed	INT32	RW	No	○	5,000	0 to 4,000,000 Hz	B
415Eh	00h	JOG/HOME/ZHOME command filter time constant	INT16	RW	No	○	1	1 to 200 ms	B
4160h	00h	(HOME) Return-to-home mode	U8	RW	No	○	1	0: 2-sensor 1: 3-sensor 2: One-way rotation	B
4161h	00h	(HOME) Return-to-home starting direction	U8	RW	No	○	1	0: Negative side 1: Positive side	B
4163h	00h	(HOME) Return-to-home starting speed	INT32	RW	No	○	5,000	1 to 4,000,000 Hz	B
4166h	00h	(HOME) Return-to-home SLIT detection	U8	RW	No	○	0	0: Disable 1: Enable	B
4167h	00h	(HOME) Return-to-home ZSG signal detection	U8	RW	No	○	0	0: Disable 2: ZSG	B
4168h	00h	(HOME) Return-to-home position offset	INT32	RW	No	○	0	-2,147,483,647 to 2,147,483,647 steps	B
4169h	00h	(HOME) Backward steps in 2 sensor return-to-home	INT32	RW	No	○	5,000	0 to 8,388,607 steps	B
416Ah	00h	(HOME) Operating amount in uni-directional return-to- home	INT32	RW	No	○	5,000	0 to 8,388,607 steps	B
4190h	00h	HWTO mode selection	U8	RW	No	○	0	0: Alarm is not present 1: Alarm is present	A
4191h	00h	HWTO delay time of checking dual system	U8	RW	No	○	0	0 to 10: Disable 11 to 100 ms	A
4198h	00h	ETO reset ineffective period	U8	RW	No	○	0	0 to 100 ms	A
4199h	00h	ETO reset action (ETO-CLR)	U8	RW	No	○	1	1: ON edge 2: ON level	A
419Ah	00h	ETO reset action (ALM-RST)	U8	RW	No	○	0	0: Disable 1: Excitation at ON edge	A
419Ch	00h	ETO reset action (STOP)	U8	RW	No	○	1	0: Disable 1: Excitation at ON edge	A
41A0h	00h	Driver temperature information (INFO-DRVTMP)	INT16	RW	RxPDO	○	85	40 to 85 °C	A
41A1h	00h	Torque limiting time information (INFO-TLCTIME)	INT16	RW	RxPDO	○	0	0: Disable 1 to 10,000 ms	A
41A2h	00h	Speed information (INFO-SPD)	INT16	RW	RxPDO	○	0	0: Disable 1 to 12,000 r/min	A
41A5h	00h	Position deviation information (INFO-POSERR)	INT16	RW	RxPDO	○	300	1 to 30,000 (1=0.01 rev)	A
41A6h	00h	Load factor information (INFO-LOAD)	U16	RW	RxPDO	○	0	0: Disable 1 to 10,000 (1=0.1 %)	A
41A7h	00h	Torque information (INFO- TRQ)	U16	RW	RxPDO	○	0	0: Disable 1 to 10,000 (1=0.1 %)	A
41A8h	00h	Motor temperature information (INFO-MTRTMP)	INT16	RW	RxPDO	○	85	40 to 120 °C	A
41A9h	00h	Overvoltage information (INFO-OVOLT)	INT16	RW	RxPDO	○	400	120 to 450 V	A
41AAh	00h	Undervoltage information (INFO-UVOLT)	INT16	RW	RxPDO	○	120	120 to 280 V	A
41AFh	00h	Tripmeter information (INFO-TRIP)	INT32	RW	RxPDO	○	0	0: Disable 1 to 2,147,483,647 (1=0.1 kRev)	A
41B0h	00h	Odometer information (INFO-ODO)	INT32	RW	RxPDO	○	0	0: Disable 1 to 2,147,483,647 (1=0.1 kRev)	A
41B1h	00h	Cumulative load 0 information (INFO-CULD0)	INT32	RW	RxPDO	○	0	0 to 2,147,483,647	A
41B2h	00h	Cumulative load 1 information (INFO-CULD1)	INT32	RW	RxPDO	○	0	0 to 2,147,483,647	A

Index	Sub	Name	Type	Access	PDO	Save	Initial value	Range	Update
41B3h	00h	Cumulative load value auto clear	U8	RW	No	○	1	0: Disable 1: Enable	A
41B4h	00h	Cumulative load value count divisor	U16	RW	No	○	1	1 to 32,767	A
41B5h	00h	Settling time information (INFO-STLTIME)	U16	RW	RxPDO	○	0	0: Disable 1 to 10,000 ms	A
41BCh	00h	INFO-USRIO output selection	U8	RW	No	○	128	Output signals list ⇨ p.116	A
41BDh	00h	INFO-USRIO output inversion	U8	RW	No	○	0	0: Non invert 1: Invert	A
41BEh	00h	Information LED condition	U8	RW	No	○	1	0: The LED does not blink 1: The LED blinks	A
41BFh	00h	Information auto clear	U8	RW	No	○	1	0: Disable (not turned OFF automatically) 1: Enable (turned OFF automatically)	A
41C2h	00h	Motor rotation direction	U8	RW	No	○	1	0: Positive side =Counterclockwise 1: Positive side=Clockwise 2: Positive side =Counterclockwise (the driver parameter is applied) 3: Positive side=Clockwise (the driver parameter is applied)	C
41C3h	00h	Software overtravel	INT8	RW	No	○	3	-1: Disable 0: Immediate stop 1: Deceleration stop 2: Immediate stop with alarm 3: Deceleration stop with alarm	A
41C6h	00h	Preset position	INT32	RW	No	○	0	-2,147,483,648 to 2,147,483,647 steps	A
41C7h	00h	Wrap (RND) setting	U8	RW	No	○	1	0: Disable 1: Enable	C
41C9h	00h	Initial coordinate generation & wrap setting range	INT32	RW	No	○	10	5 to 655,360 (1=0.1 rev)	C
41CBh	00h	Initial coordinate generation & wrap range offset ratio	U16	RW	No	○	5,000	0 to 10,000 (1=0.01 %)	C
41CCh	00h	Initial coordinate generation & wrap range offset value	INT32	RW	No	○	0	-536,870,912 to 536,870,911 steps	C
41CDh	00h	The number of the RND-ZERO output in wrap range	INT32	RW	No	○	1	1 to 536,870,911	C
41FFh	00h	Driver simulation mode	U8	RW	No	○	0	0: The motor is actually used 1: Virtual motor (when ABZO not connected=no ABZO information) 2: Virtual motor (when ABZO not connected=1,800 rev wrap enable) 3: Virtual motor (when ABZO not connected=900 rev wrap enable)	D
44B0h	00h	Touch probe 1 latch position	U8	RW	No	○	0	0: Latches the feedback position 1: Latches the command position	A
44B1h	00h	Touch probe 2 latch position	U8	RW	No	○	0	0: Latches the feedback position 1: Latches the command position	A
4510h	00h	Information history 1	INT32	RO	No	–	–	–	–
4511h	00h	Information history 2	INT32	RO	No	–	–		
4512h	00h	Information history 3	INT32	RO	No	–	–		
4513h	00h	Information history 4	INT32	RO	No	–	–		
4514h	00h	Information history 5	INT32	RO	No	–	–		
4515h	00h	Information history 6	INT32	RO	No	–	–		

Index	Sub	Name	Type	Access	PDO	Save	Initial value	Range	Update		
4516h	00h	Information history 7	INT32	RO	No	–	–	–	–		
4517h	00h	Information history 8	INT32	RO	No	–	–				
4518h	00h	Information history 9	INT32	RO	No	–	–				
4519h	00h	Information history 10	INT32	RO	No	–	–				
451Ah	00h	Information history 11	INT32	RO	No	–	–				
451Bh	00h	Information history 12	INT32	RO	No	–	–				
451Ch	00h	Information history 13	INT32	RO	No	–	–				
451Dh	00h	Information history 14	INT32	RO	No	–	–				
451Eh	00h	Information history 15	INT32	RO	No	–	–				
451Fh	00h	Information history 16	INT32	RO	No	–	–				
4520h	00h	Information time history 1	INT32	RO	No	–	–			–	–
4521h	00h	Information time history 2	INT32	RO	No	–	–				
4522h	00h	Information time history 3	INT32	RO	No	–	–				
4523h	00h	Information time history 4	INT32	RO	No	–	–				
4524h	00h	Information time history 5	INT32	RO	No	–	–				
4525h	00h	Information time history 6	INT32	RO	No	–	–				
4526h	00h	Information time history 7	INT32	RO	No	–	–				
4527h	00h	Information time history 8	INT32	RO	No	–	–				
4528h	00h	Information time history 9	INT32	RO	No	–	–				
4529h	00h	Information time history 10	INT32	RO	No	–	–				
452Ah	00h	Information time history 11	INT32	RO	No	–	–				
452Bh	00h	Information time history 12	INT32	RO	No	–	–				
452Ch	00h	Information time history 13	INT32	RO	No	–	–				
452Dh	00h	Information time history 14	INT32	RO	No	–	–				
452Eh	00h	Information time history 15	INT32	RO	No	–	–				
452Fh	00h	Information time history 16	INT32	RO	No	–	–				
45E0h	00h	FFT Value (1st peak)	U16	RO	No	–	–	–	–		
45E1h	00h	FFT Frequency (1st peak)	U16	RO	No	–	–				
45E2h	00h	FFT Value (2nd peak)	U16	RO	No	–	–				
45E3h	00h	FFT Frequency (2nd peak)	U16	RO	No	–	–				
45E4h	00h	FFT Value (3rd peak)	U16	RO	No	–	–				
45E5h	00h	FFT Frequency (3rd peak)	U16	RO	No	–	–				
45E6h	00h	FFT Value (4th peak)	U16	RO	No	–	–				
45E7h	00h	FFT Frequency (4th peak)	U16	RO	No	–	–				
4642h	00h	Driver CPU number	U16	RO	No	–	–	–	–		
4643h	00h	Driver software version	U16	RO	No	–	–	–	–		
4700h	00h	STOP input action	INT8	RW	No	○	3	0: Immediate stop 3: Deceleration stop	A		
4701h	00h	FW-LS/RV-LS input action	INT8	RW	No	○	2	–1: Used as a return-to-home sensor 0: Immediate stop 1: Deceleration stop 2: Immediate stop with alarm 3: Deceleration stop with alarm	A		
4702h	00h	FW-BLK, RV-BLK input action	INT8	RW	No	○	0	0: Immediate stop 1: Deceleration stop	A		
4704h	00h	IN-POS positioning completion signal offset	INT16	RW	No	○	0	–18 to 18 (1=0.1°)	A		
4707h	00h	ZSG signal width	U16	RW	No	○	18	1 to 1,800 (1=0.1°)	A		
4708h	00h	RND-ZERO signal width	U16	RW	No	○	10	1 to 10,000 steps	A		
4709h	00h	RND-ZERO output data selection	U8	RW	No	○	0	0: Based on feedback position 1: Based on command position	A		
470Ah	00h	MOVE minimum ON time	U8	RW	No	○	0	0 to 255 ms	A		

Index	Sub	Name	Type	Access	PDO	Save	Initial value	Range	Update
470Eh	00h	SPD-LMT speed limit type selection	INT8	RW	No	<input type="radio"/>	0	0: Ratio 1: Value	A
470Fh	00h	SPD-LMT speed limit ratio	INT8	RW	No	<input type="radio"/>	50	1 to 100 %	A
4710h	00h	SPD-LMT speed limit value	INT32	RW	No	<input type="radio"/>	10,000	1 to 4,000,000 Hz	A
4718h	00h	VA mode selection	U8	RW	No	<input type="radio"/>	2	0: Actual speed attainment (speed at feedback position) 1: Speed at command position (only internal profile) 2: Speed at feedback position & command position (only internal profile)	A
4719h	00h	VA detection speed range	U8	RW	No	<input type="radio"/>	30	1 to 200 r/min	B
471Dh	00h	ZV detection speed range	U8	RW	No	<input type="radio"/>	15	0 to 200 r/min	A
4740h	00h	AREA0 positive direction position/offset	INT32	RW	No	<input type="radio"/>	0	-2,147,483,648 to 2,147,483,647 steps	A
4741h	00h	AREA0 negative direction position/detection range	INT32	RW	No	<input type="radio"/>	0		
4742h	00h	AREA1 positive direction position/offset	INT32	RW	No	<input type="radio"/>	0		
4743h	00h	AREA1 negative direction position/detection range	INT32	RW	No	<input type="radio"/>	0		
4744h	00h	AREA2 positive direction position/offset	INT32	RW	No	<input type="radio"/>	0		
4745h	00h	AREA2 negative direction position/detection range	INT32	RW	No	<input type="radio"/>	0		
4746h	00h	AREA3 positive direction position/offset	INT32	RW	No	<input type="radio"/>	0		
4747h	00h	AREA3 negative direction position/detection range	INT32	RW	No	<input type="radio"/>	0		
4748h	00h	AREA4 positive direction position/offset	INT32	RW	No	<input type="radio"/>	0		
4749h	00h	AREA4 negative direction position/detection range	INT32	RW	No	<input type="radio"/>	0		
474Ah	00h	AREA5 positive direction position/offset	INT32	RW	No	<input type="radio"/>	0		
474Bh	00h	AREA5 negative direction position/detection range	INT32	RW	No	<input type="radio"/>	0		
474Ch	00h	AREA6 positive direction position/offset	INT32	RW	No	<input type="radio"/>	0		
474Dh	00h	AREA6 negative direction position/detection range	INT32	RW	No	<input type="radio"/>	0		
474Eh	00h	AREA7 positive direction position/offset	INT32	RW	No	<input type="radio"/>	0		
474Fh	00h	AREA7 negative direction position/detection range	INT32	RW	No	<input type="radio"/>	0		
4750h	00h	AREA0 range setting mode	U8	RW	No	<input type="radio"/>	0	0: Range setting with absolute value 1: Offset/width setting from the target position	A
4751h	00h	AREA1 range setting mode	U8	RW	No	<input type="radio"/>	0		
4752h	00h	AREA2 range setting mode	U8	RW	No	<input type="radio"/>	0		
4753h	00h	AREA3 range setting mode	U8	RW	No	<input type="radio"/>	0		
4754h	00h	AREA4 range setting mode	U8	RW	No	<input type="radio"/>	0		
4755h	00h	AREA5 range setting mode	U8	RW	No	<input type="radio"/>	0		
4756h	00h	AREA6 range setting mode	U8	RW	No	<input type="radio"/>	0		
4757h	00h	AREA7 range setting mode	U8	RW	No	<input type="radio"/>	0		
4758h	00h	AREA0 positioning standard	U8	RW	No	<input type="radio"/>	0	0: Based on feedback position 1: Based on command position	A
4759h	00h	AREA1 positioning standard	U8	RW	No	<input type="radio"/>	0		
475Ah	00h	AREA2 positioning standard	U8	RW	No	<input type="radio"/>	0		
475Bh	00h	AREA3 positioning standard	U8	RW	No	<input type="radio"/>	0		
475Ch	00h	AREA4 positioning standard	U8	RW	No	<input type="radio"/>	0		

Objects of manufacturer-specific area

Index	Sub	Name	Type	Access	PDO	Save	Initial value	Range	Update
475Dh	00h	AREA5 positioning standard	U8	RW	No	<input type="radio"/>	0	0: Based on feedback position 1: Based on command position	A
475Eh	00h	AREA6 positioning standard	U8	RW	No	<input type="radio"/>	0		
475Fh	00h	AREA7 positioning standard	U8	RW	No	<input type="radio"/>	0		
47A0h	00h	INFO action (Assigned I/O status information (INFO-USRIO))	U8	RW	No	<input type="radio"/>	1	0: Only the bit output is ON 1: The bit output and the INFO output are ON and the LED blinks	A
47A1h	00h	INFO action (Position deviation information (INFO-POSERR))	U8	RW	No	<input type="radio"/>	1		
47A2h	00h	INFO action (Driver temperature information (INFO-DRVTMP))	U8	RW	No	<input type="radio"/>	1		
47A3h	00h	INFO action (Motor temperature information (INFO-MTRTMP))	U8	RW	No	<input type="radio"/>	1		
47A4h	00h	INFO action (Overvoltage information (INFO-OVOLT))	U8	RW	No	<input type="radio"/>	1		
47A5h	00h	INFO action (Undervoltage information (INFO-UVOLT))	U8	RW	No	<input type="radio"/>	1		
47A6h	00h	INFO action (Torque limiting time information (INFO-TLCTIME))	U8	RW	No	<input type="radio"/>	1		
47A7h	00h	INFO action (Load factor information (INFO-LOAD))	U8	RW	No	<input type="radio"/>	1		
47A8h	00h	INFO action (Speed information (INFO-SPD))	U8	RW	No	<input type="radio"/>	1		
47A9h	00h	INFO action (Start operation error information (INFO-START))	U8	RW	No	<input type="radio"/>	1		
47AAh	00h	INFO action (Start ZHOME error information (INFO-ZHOME))	U8	RW	No	<input type="radio"/>	1		
47ABh	00h	INFO action (PRESET request information (INFO-PR-REQ))	U8	RW	No	<input type="radio"/>	1		
47ADh	00h	INFO action (Electronic gear setting error information (INFO-EGR-E))	U8	RW	No	<input type="radio"/>	1		
47AEh	00h	INFO action (Wrap setting error information (INFO-RND-E))	U8	RW	No	<input type="radio"/>	1		
47B0h	00h	INFO action (Forward operation prohibition information (INFO-FW-OT))	U8	RW	No	<input type="radio"/>	1		
47B1h	00h	INFO action (Reverse operation prohibition information (INFO-RV-OT))	U8	RW	No	<input type="radio"/>	1		
47B2h	00h	INFO action (Cumulative load 0 information (INFO-CULD0))	U8	RW	No	<input type="radio"/>	1		
47B3h	00h	INFO action (Cumulative load 1 information (INFO-CULD1))	U8	RW	No	<input type="radio"/>	1		
47B4h	00h	INFO action (Tripmeter information (INFO-TRIP))	U8	RW	No	<input type="radio"/>	1		
47B5h	00h	INFO action (Odometer information (INFO-ODO))	U8	RW	No	<input type="radio"/>	1		
47B7h	00h	INFO action (Torque information (INFO-TRQ))	U8	RW	No	<input type="radio"/>	1		
47B8h	00h	INFO action (Settling time information (INFO-STLTIME))	U8	RW	No	<input type="radio"/>	1		
47BCh	00h	INFO action (Start operation restricted mode information (INFO-DSLMTD))	U8	RW	No	<input type="radio"/>	1		

Index	Sub	Name	Type	Access	PDO	Save	Initial value	Range	Update
47BDh	00h	INFO action (I/O test mode information (INFO-IOTEST))	U8	RW	No	<input type="radio"/>	1	0: Only the bit output is ON 1: The bit output and the INFO output are ON and the LED blinks	A
47BEh	00h	INFO action (Configuration request information (INFO-CFG))	U8	RW	No	<input type="radio"/>	1		
47BFh	00h	INFO action (Reboot request information (INFO-RBT))	U8	RW	No	<input type="radio"/>	1		
47F0h	00h	Mechanism settings	U8	RW	No	<input type="radio"/>	1	0: Prioritize ABZO setting 1: Manual setting	D
47F1h	00h	Gear ratio setting	INT16	RW	No	<input type="radio"/>	0	0: Gear ratio setting disable 1 to 32,767: Gear ratio (1=0.01)	C
47F2h	00h	Initial coordinate generation & wrap coordinate setting	U8	RW	No	<input type="radio"/>	0	0: Prioritize ABZO setting 1: Manual setting	D
47F3h	00h	Mechanism limit parameter setting	U8	RW	No	<input type="radio"/>	0	0: Follow ABZO setting 1: Disable	D
47F4h	00h	Mechanism protection parameter setting	U8	RW	No	<input type="radio"/>	0	0: Follow ABZO setting 1: Disable	D
47F5h	00h	JOG/HOME/ZHOME operation setting	U8	RW	No	<input type="radio"/>	0	0: Prioritize ABZO setting 1: Manual setting	D
4810h	00h	Damping control frequency	U16	RW	No	<input type="radio"/>	10,000	700 to 20,000 (1=0.01 Hz)	A
4811h	00h	Damping control gain	INT8	RW	No	<input type="radio"/>	0	0 to 100 %	A
4813h	00h	Resonance suppression control A frequency	INT16	RW	No	<input type="radio"/>	1,000	100 to 3,200 Hz	A
4814h	00h	Resonance suppression control A gain	INT8	RW	No	<input type="radio"/>	0	0 to 100 %	A
4815h	00h	Resonance suppression control A width	U8	RW	No	<input type="radio"/>	30	30 to 120	A
4816h	00h	Resonance suppression control B frequency	INT16	RW	No	<input type="radio"/>	1,000	100 to 3,200 Hz	A
4817h	00h	Resonance suppression control B gain	INT8	RW	No	<input type="radio"/>	0	0 to 100 %	A
4818h	00h	Resonance suppression control B width	U8	RW	No	<input type="radio"/>	30	30 to 120	A
4819h	00h	Resonance suppression control C frequency	INT16	RW	No	<input type="radio"/>	1,000	100 to 3,200 Hz	A
481Ah	00h	Resonance suppression control C gain	INT8	RW	No	<input type="radio"/>	0	0 to 100 %	A
481Bh	00h	Resonance suppression control C width	U8	RW	No	<input type="radio"/>	30	30 to 120	A
481Ch	00h	Resonance suppression control D frequency	INT16	RW	No	<input type="radio"/>	1,000	100 to 3,200 Hz	A
481Dh	00h	Resonance suppression control D gain	INT8	RW	No	<input type="radio"/>	0	0 to 100 %	A
481Eh	00h	Resonance suppression control D width	U8	RW	No	<input type="radio"/>	30	30 to 120	A
4840h	00h	DIN0 input function	U8	RW	No	<input type="radio"/>	30	Input signals list ⇨ p.115	C
4841h	00h	DIN1 input function	U8	RW	No	<input type="radio"/>	1		
4842h	00h	DIN2 input function	U8	RW	No	<input type="radio"/>	12		
4843h	00h	DIN3 input function	U8	RW	No	<input type="radio"/>	104		
4844h	00h	DIN4 input function	U8	RW	No	<input type="radio"/>	28		
4845h	00h	DIN5 input function	U8	RW	No	<input type="radio"/>	29		
4850h	00h	DIN0 inverting mode	U8	RW	No	<input type="radio"/>	0	0: Non invert 1: Invert	C
4851h	00h	DIN1 inverting mode	U8	RW	No	<input type="radio"/>	0		
4852h	00h	DIN2 inverting mode	U8	RW	No	<input type="radio"/>	0		
4853h	00h	DIN3 inverting mode	U8	RW	No	<input type="radio"/>	0		
4854h	00h	DIN4 inverting mode	U8	RW	No	<input type="radio"/>	0		
4855h	00h	DIN5 inverting mode	U8	RW	No	<input type="radio"/>	0		

Index	Sub	Name	Type	Access	PDO	Save	Initial value	Range	Update
4860h	00h	DOUT0 (Normal) output function	U8	RW	No	<input type="radio"/>	144	Output signals list ⇨ p.116	C
4861h	00h	DOUT1 (Normal) output function	U8	RW	No	<input type="radio"/>	137		
4862h	00h	DOUT2 (Normal) output function	U8	RW	No	<input type="radio"/>	0		
4863h	00h	DOUT3 (Normal) output function	U8	RW	No	<input type="radio"/>	142		
4864h	00h	DOUT4 (Normal) output function	U8	RW	No	<input type="radio"/>	134		
4865h	00h	DOUT5 (Normal) output function	U8	RW	No	<input type="radio"/>	130		
4870h	00h	DOUT0 inverting mode	U8	RW	No	<input type="radio"/>	0	0: Non invert 1: Invert	C
4871h	00h	DOUT1 inverting mode	U8	RW	No	<input type="radio"/>	0		
4872h	00h	DOUT2 inverting mode	U8	RW	No	<input type="radio"/>	0		
4873h	00h	DOUT3 inverting mode	U8	RW	No	<input type="radio"/>	0		
4874h	00h	DOUT4 inverting mode	U8	RW	No	<input type="radio"/>	0		
4875h	00h	DOUT5 inverting mode	U8	RW	No	<input type="radio"/>	0		
4880h	00h	DIN0 composite input function	U8	RW	No	<input type="radio"/>	0	Input signals list ⇨ p.115	C
4881h	00h	DIN1 composite input function	U8	RW	No	<input type="radio"/>	0		
4882h	00h	DIN2 composite input function	U8	RW	No	<input type="radio"/>	0		
4883h	00h	DIN3 composite input function	U8	RW	No	<input type="radio"/>	0		
4884h	00h	DIN4 composite input function	U8	RW	No	<input type="radio"/>	0		
4885h	00h	DIN5 composite input function	U8	RW	No	<input type="radio"/>	0		
4890h	00h	DOUT0 composite output function	U8	RW	No	<input type="radio"/>	128	Output signals list ⇨ p.116	C
4891h	00h	DOUT1 composite output function	U8	RW	No	<input type="radio"/>	128		
4892h	00h	DOUT2 composite output function	U8	RW	No	<input type="radio"/>	128		
4893h	00h	DOUT3 composite output function	U8	RW	No	<input type="radio"/>	128		
4894h	00h	DOUT4 composite output function	U8	RW	No	<input type="radio"/>	128		
4895h	00h	DOUT5 composite output function	U8	RW	No	<input type="radio"/>	128		
48A0h	00h	DOUT0 composite inverting mode	U8	RW	No	<input type="radio"/>	0	0: Non invert 1: Invert	C
48A1h	00h	DOUT1 composite inverting mode	U8	RW	No	<input type="radio"/>	0		
48A2h	00h	DOUT2 composite inverting mode	U8	RW	No	<input type="radio"/>	0		
48A3h	00h	DOUT3 composite inverting mode	U8	RW	No	<input type="radio"/>	0		
48A4h	00h	DOUT4 composite inverting mode	U8	RW	No	<input type="radio"/>	0		
48A5h	00h	DOUT5 composite inverting mode	U8	RW	No	<input type="radio"/>	0		
48B0h	00h	DOUT0 composite logical combination	U8	RW	No	<input type="radio"/>	1	0: AND 1: OR	C
48B1h	00h	DOUT1 composite logical combination	U8	RW	No	<input type="radio"/>	1		

Index	Sub	Name	Type	Access	PDO	Save	Initial value	Range	Update
48B2h	00h	DOUT2 composite logical combination	U8	RW	No	<input type="radio"/>	1	0: AND 1: OR	C
48B3h	00h	DOUT3 composite logical combination	U8	RW	No	<input type="radio"/>	1		
48B4h	00h	DOUT4 composite logical combination	U8	RW	No	<input type="radio"/>	1		
48B5h	00h	DOUT5 composite logical combination	U8	RW	No	<input type="radio"/>	1		
48C0h	00h	DIN0 ON signal dead-time	U8	RW	No	<input type="radio"/>	0	0 to 250 ms	C
48C1h	00h	DIN1 ON signal dead-time	U8	RW	No	<input type="radio"/>	0		
48C2h	00h	DIN2 ON signal dead-time	U8	RW	No	<input type="radio"/>	0		
48C3h	00h	DIN3 ON signal dead-time	U8	RW	No	<input type="radio"/>	0		
48C4h	00h	DIN4 ON signal dead-time	U8	RW	No	<input type="radio"/>	0		
48C5h	00h	DIN5 ON signal dead-time	U8	RW	No	<input type="radio"/>	0	0: Disable 1: Enable	C
48D0h	00h	DIN0 1 shot signal	U8	RW	No	<input type="radio"/>	0		
48D1h	00h	DIN1 1 shot signal	U8	RW	No	<input type="radio"/>	0		
48D2h	00h	DIN2 1 shot signal	U8	RW	No	<input type="radio"/>	0		
48D3h	00h	DIN3 1 shot signal	U8	RW	No	<input type="radio"/>	0		
48D4h	00h	DIN4 1 shot signal	U8	RW	No	<input type="radio"/>	0	0 to 250 ms	C
48D5h	00h	DIN5 1 shot signal	U8	RW	No	<input type="radio"/>	0		
48E0h	00h	DOUT0 OFF delay time	U8	RW	No	<input type="radio"/>	0		
48E1h	00h	DOUT1 OFF delay time	U8	RW	No	<input type="radio"/>	0		
48E2h	00h	DOUT2 OFF delay time	U8	RW	No	<input type="radio"/>	0		
48E3h	00h	DOUT3 OFF delay time	U8	RW	No	<input type="radio"/>	0	Input signals list ⇨ p.115	C
48E4h	00h	DOUT4 OFF delay time	U8	RW	No	<input type="radio"/>	0		
48E5h	00h	DOUT5 OFF delay time	U8	RW	No	<input type="radio"/>	0		
4900h	00h	R-IN0 input function	U8	RW	No	<input type="radio"/>	0		
4901h	00h	R-IN1 input function	U8	RW	No	<input type="radio"/>	0		
4902h	00h	R-IN2 input function	U8	RW	No	<input type="radio"/>	0		
4903h	00h	R-IN3 input function	U8	RW	No	<input type="radio"/>	0		
4904h	00h	R-IN4 input function	U8	RW	No	<input type="radio"/>	0		
4905h	00h	R-IN5 input function	U8	RW	No	<input type="radio"/>	0		
4906h	00h	R-IN6 input function	U8	RW	No	<input type="radio"/>	0		
4907h	00h	R-IN7 input function	U8	RW	No	<input type="radio"/>	0		
4908h	00h	R-IN8 input function	U8	RW	No	<input type="radio"/>	0		
4909h	00h	R-IN9 input function	U8	RW	No	<input type="radio"/>	0		
490Ah	00h	R-IN10 input function	U8	RW	No	<input type="radio"/>	0		
490Bh	00h	R-IN11 input function	U8	RW	No	<input type="radio"/>	0		
490Ch	00h	R-IN12 input function	U8	RW	No	<input type="radio"/>	0		
490Dh	00h	R-IN13 input function	U8	RW	No	<input type="radio"/>	0		
490Eh	00h	R-IN14 input function	U8	RW	No	<input type="radio"/>	0		
490Fh	00h	R-IN15 input function	U8	RW	No	<input type="radio"/>	0	Output signals list ⇨ p.116	C
4910h	00h	R-OUT0 output function	U8	RW	No	<input type="radio"/>	28		
4911h	00h	R-OUT1 output function	U8	RW	No	<input type="radio"/>	29		
4912h	00h	R-OUT2 output function	U8	RW	No	<input type="radio"/>	155		
4913h	00h	R-OUT3 output function	U8	RW	No	<input type="radio"/>	0		
4914h	00h	R-OUT4 output function	U8	RW	No	<input type="radio"/>	144		
4915h	00h	R-OUT5 output function	U8	RW	No	<input type="radio"/>	204		
4916h	00h	R-OUT6 output function	U8	RW	No	<input type="radio"/>	135		
4917h	00h	R-OUT7 output function	U8	RW	No	<input type="radio"/>	129		
4918h	00h	R-OUT8 output function	U8	RW	No	<input type="radio"/>	136		
4919h	00h	R-OUT9 output function	U8	RW	No	<input type="radio"/>	160		
491Ah	00h	R-OUT10 output function	U8	RW	No	<input type="radio"/>	161		

Index	Sub	Name	Type	Access	PDO	Save	Initial value	Range	Update
491Bh	00h	R-OUT11 output function	U8	RW	No	<input type="radio"/>	162	Output signals list ⇨ p.116	C
491Ch	00h	R-OUT12 output function	U8	RW	No	<input type="radio"/>	0		
491Dh	00h	R-OUT13 output function	U8	RW	No	<input type="radio"/>	134		
491Eh	00h	R-OUT14 output function	U8	RW	No	<input type="radio"/>	138		
491Fh	00h	R-OUT15 output function	U8	RW	No	<input type="radio"/>	140		
4930h	00h	R-OUT0 OFF delay time	U8	RW	No	<input type="radio"/>	0	0 to 250 ms	C
4931h	00h	R-OUT1 OFF delay time	U8	RW	No	<input type="radio"/>	0		
4932h	00h	R-OUT2 OFF delay time	U8	RW	No	<input type="radio"/>	0		
4933h	00h	R-OUT3 OFF delay time	U8	RW	No	<input type="radio"/>	0		
4934h	00h	R-OUT4 OFF delay time	U8	RW	No	<input type="radio"/>	0		
4935h	00h	R-OUT5 OFF delay time	U8	RW	No	<input type="radio"/>	0		
4936h	00h	R-OUT6 OFF delay time	U8	RW	No	<input type="radio"/>	0		
4937h	00h	R-OUT7 OFF delay time	U8	RW	No	<input type="radio"/>	0		
4938h	00h	R-OUT8 OFF delay time	U8	RW	No	<input type="radio"/>	0		
4939h	00h	R-OUT9 OFF delay time	U8	RW	No	<input type="radio"/>	0		
493Ah	00h	R-OUT10 OFF delay time	U8	RW	No	<input type="radio"/>	0		
493Bh	00h	R-OUT11 OFF delay time	U8	RW	No	<input type="radio"/>	0		
493Ch	00h	R-OUT12 OFF delay time	U8	RW	No	<input type="radio"/>	0		
493Dh	00h	R-OUT13 OFF delay time	U8	RW	No	<input type="radio"/>	0		
493Eh	00h	R-OUT14 OFF delay time	U8	RW	No	<input type="radio"/>	0		
493Fh	00h	R-OUT15 OFF delay time	U8	RW	No	<input type="radio"/>	0		
4940h	00h	Virtual input (VIR-IN0) function	U8	RW	No	<input type="radio"/>	0	Input signals list ⇨ p.115	C
4941h	00h	Virtual input (VIR-IN1) function	U8	RW	No	<input type="radio"/>	0		
4942h	00h	Virtual input (VIR-IN2) function	U8	RW	No	<input type="radio"/>	0		
4943h	00h	Virtual input (VIR-IN3) function	U8	RW	No	<input type="radio"/>	0		
4944h	00h	Virtual input (VIR-IN0) source selection	U8	RW	No	<input type="radio"/>	128	Output signals list ⇨ p.116	C
4945h	00h	Virtual input (VIR-IN1) source selection	U8	RW	No	<input type="radio"/>	128		
4946h	00h	Virtual input (VIR-IN2) source selection	U8	RW	No	<input type="radio"/>	128		
4947h	00h	Virtual input (VIR-IN3) source selection	U8	RW	No	<input type="radio"/>	128		
4948h	00h	Virtual input (VIR-IN0) inverting mode	U8	RW	No	<input type="radio"/>	0	0: Non invert 1: Invert	C
4949h	00h	Virtual input (VIR-IN1) inverting mode	U8	RW	No	<input type="radio"/>	0		
494Ah	00h	Virtual input (VIR-IN2) inverting mode	U8	RW	No	<input type="radio"/>	0		
494Bh	00h	Virtual input (VIR-IN3) inverting mode	U8	RW	No	<input type="radio"/>	0		
494Ch	00h	Virtual input (VIR-IN0) ON signal dead time	U8	RW	No	<input type="radio"/>	0	0 to 250 ms	C
494Dh	00h	Virtual input (VIR-IN1) ON signal dead time	U8	RW	No	<input type="radio"/>	0		
494Eh	00h	Virtual input (VIR-IN2) ON signal dead time	U8	RW	No	<input type="radio"/>	0		
494Fh	00h	Virtual input (VIR-IN3) ON signal dead time	U8	RW	No	<input type="radio"/>	0		
4950h	00h	Virtual input (VIR-IN0) 1 shot signal mode	U8	RW	No	<input type="radio"/>	0	0: Disable 1: Enable	C
4951h	00h	Virtual input (VIR-IN1) 1 shot signal mode	U8	RW	No	<input type="radio"/>	0		
4952h	00h	Virtual input (VIR-IN2) 1 shot signal mode	U8	RW	No	<input type="radio"/>	0		

Index	Sub	Name	Type	Access	PDO	Save	Initial value	Range	Update
4953h	00h	Virtual input (VIR-IN3) 1 shot signal mode	U8	RW	No	<input type="radio"/>	0	0: Disable 1: Enable	C
4960h	00h	User output (USR-OUT0) source A function	U8	RW	No	<input type="radio"/>	128	Output signals list ⇨ p.116	C
4961h	00h	User output (USR-OUT1) source A function	U8	RW	No	<input type="radio"/>	128		
4962h	00h	User output (USR-OUT0) source A inverting mode	U8	RW	No	<input type="radio"/>	0	0: Non invert 1: Invert	C
4963h	00h	User output (USR-OUT1) source A inverting mode	U8	RW	No	<input type="radio"/>	0		
4964h	00h	User output (USR-OUT0) source B function	U8	RW	No	<input type="radio"/>	128	Output signals list ⇨ p.116	C
4965h	00h	User output (USR-OUT1) source B function	U8	RW	No	<input type="radio"/>	128		
4966h	00h	User output (USR-OUT0) source B inverting mode	U8	RW	No	<input type="radio"/>	0	0: Non invert 1: Invert	C
4967h	00h	User output (USR-OUT1) source B inverting mode	U8	RW	No	<input type="radio"/>	0		
4968h	00h	User output (USR-OUT0) logical operation	U8	RW	No	<input type="radio"/>	1	0: AND 1: OR	C
4969h	00h	User output (USR-OUT1) logical operation	U8	RW	No	<input type="radio"/>	1		
4970h	00h	Extended input (EXT-IN) function	U8	RW	No	<input type="radio"/>	9	Input signals list ⇨ p.115	C
4971h	00h	Extended input (EXT-IN) inverting mode	U8	RW	No	<input type="radio"/>	0	0: Non invert 1: Invert	C
4972h	00h	Extended input (EXT-IN) interlock releasing time	INT8	RW	No	<input type="radio"/>	10	0: Disable 1 to 50 (1=0.1 s)	A
4973h	00h	Extended input (EXT-IN) interlock releasing duration	INT8	RW	No	<input type="radio"/>	30	0 to 50 (1=0.1 s)	A
4974h	00h	Extended input (EXT-IN) ON monitor time	INT8	RW	No	<input type="radio"/>	10	0 to 50 (1=0.1 s)	A
49E2h	00h	FFT target	INT8	RW	No	<input type="radio"/>	0	0: Torque 1: Speed	A

■ Reference example of ON signal dead-time [ms]

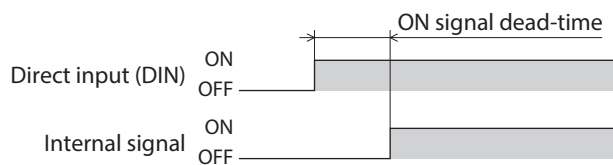

■ Reference example of OFF output-delay time [ms]

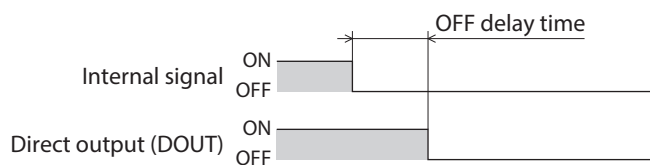



6 Troubleshooting

This part explains alarm and information functions.

◆ Table of contents

1	Alarms.....	196
1-1	Alarm reset.....	196
1-2	Alarm history.....	196
1-3	Generation condition of alarms	198
1-4	Alarm list.....	198
1-5	Timing chart	204
2	Information.....	205
2-1	Information history.....	207
2-2	Information list	207
3	Troubleshooting and remedial actions	212



1 Alarms

This driver is equipped with the alarm function to protect against temperature rise, poor connection, operation error, and the like.

If an alarm is generated, the ALM-A output is turned ON and the ALM-B output is turned OFF to stop the motor. At the same time, the PWR/ALM LED blinks in red.

The alarm being generated can be checked via EtherCAT, using the **MEXE02** software, or by counting the number of blinks of the PWR/ALM LED.

Refer to the [OPERATING MANUAL Hardware Edition](#) for the indication of the LEDs.

1-1 Alarm reset

Before resetting an alarm, always remove the cause of the alarm and ensure safety, and perform one of the reset operations specified below.

- Set the Fault reset (6040h: bit 7) of Controlword to 1. (It is enabled when changing from 0 to 1.)
- Turn the ALM-RST input ON. (It is enabled at the ON edge.)
- Execute the alarm reset using the **MEXE02** software.
- Turn on the control power supply again.



- Some alarms cannot be reset by other methods than turning on the control power supply again. Check with "1-4 Alarm list" on p.198.
- An alarm of Absolute position error can be reset if position preset or return-to-home operation is performed. If it cannot be reset by these methods, the ABZO sensor may be damaged.

1-2 Alarm history

Up to 10 generated alarm items are stored in the non-volatile memory in order of the latest to the oldest. The stored alarm history can be read or cleared if one of the following is performed.

- Read the alarm history by the Alarm history (4041h to 404Ah) via EtherCAT.
- Clear the alarm history by setting the Clear alarm history (40C2h) of EtherCAT to 1. (It is enabled when changing from 0 to 1.)
- Read and clear the alarm history using the **MEXE02** software.

■ Items that can be checked in the alarm history

Item	Description
Code	This is an alarm code.
Alarm message	This is the description of the alarm. Details of the alarm cannot be checked via EtherCAT. Check with the alarm monitor of the MEXE02 software.
Sub code	This is the code to be checked by Oriental Motor. However, when the operation data error (alarm code 70h) occurs, the cause of the alarm can be checked by a customer if the sub code is used. (Refer to ⇨ p.197)
Driver temperature	This is the driver temperature when an alarm was generated.
Motor temperature	This is the motor temperature when an alarm was generated.
Inverter voltage	This is the inverter voltage when an alarm was generated.
Physical I/O input	Indicates the status of direct I/O in 16 bits when an alarm was generated.
R-I/O output	Indicates the status of R-OUT in 16 bits when an alarm was generated.
Operation information 0	This is the operation data number that was being executed when an alarm was generated.
Operation information 1	Indicates the operation that was being executed in a number when an alarm was generated.
Feedback position	This is the feedback position of the motor when an alarm was generated.
Elapsed time from BOOT	This is the elapsed time from when the control power supply was turned on to when an alarm was generated.

Item	Description
Elapsed time from starting operation	This is the elapsed time from when the operation was started to when an alarm was generated.
Main power supply time	This is the elapsed time from when the main power was turned on to when an alarm was generated.
Motor model	This is the name of the motor that was connected to the driver when an alarm was generated.
Motor serial number	This is the serial number of the motor that was connected to the driver when an alarm was generated.



The R-I/O output is monitored internally even if industrial network is not used. If an output signal that is desired to monitor is assigned to the R-OUT output, the number of monitors when an alarm is generated can be increased.

- **Sub codes of operation data error (alarm code 70h)**

Sub code	Cause of alarm
01h	Positioning operation was executed in a state where the travel amount was set to a value less than -2,147,483,647 steps or more than 2,147,483,647 steps.
02h	Operation using the wrap function was executed in a state where the wrap function was disabled.
03h	Positioning operation was executed with the speed of 0 Hz while the travel amount was set to a value other than 0 step.
04h	The operating speed exceeded the maximum operating speed set in the ABZO sensor when the Mechanism protection parameter setting (47F4h) was set to "0: Follow ABZO setting."
05h	The starting speed exceeded the maximum starting speed set in the ABZO sensor when the Mechanism protection parameter setting (47F4h) was set to "0: Follow ABZO setting."
08h	The object related to return-to-home exceeded the value set in the ABZO sensor when the Mechanism protection parameter setting (47F4h) was set to "0: Follow ABZO setting."

Related object

Index	Sub	Name	Type	Access	PDO	Save	Range	Update
47F4h	00h	Mechanism protection parameter setting	U8	RW	No	○	0: Follow ABZO setting 1: Disable	D

- **Details of bits for physical I/O input**

Bit 15	Bit 14	Bit 13	Bit 12	Bit 11	Bit 10	Bit 9	Bit 8
VIR-IN3	VIR-IN2	VIR-IN1	VIR-IN0	–	EXT-IN	–	–
Bit 7	Bit 6	Bit 5	Bit 4	Bit 3	Bit 2	Bit 1	Bit 0
–	–	DIN5	DIN4	DIN3	DIN2	DIN1	DIN0

- **Details of bits for R-IN output**

Bit 7	Bit 6	Bit 5	Bit 4	Bit 3	Bit 2	Bit 1	Bit 0
R-OUT15	R-OUT14	R-OUT13	R-OUT12	R-OUT11	R-OUT10	R-OUT9	R-OUT8

1-3 Generation condition of alarms

Alarms shown in the table will be generated if the generation condition is exceeded.

Alarm code	Alarm name	Generation condition
21h	Main circuit overheat	85 °C (185 °F)
22h	Overvoltage	400 V
26h	Motor overheat	85 °C (185 °F)
31h	Overspeed	AZXM1075, AZXM1175: 5,000 r/min Other than the above motors: 6,000 r/min
34h	Command position error	15,000 r/min

1-4 Alarm list



If an alarm is generated, the motor goes into a non-excitation state.

Alarm code	Number of times LED blinks	Alarm type	Cause	Remedial action	How to reset
10h	4	Excessive position deviation	<ul style="list-style-type: none"> When the motor was in an excitation state, the deviation between the command position and the feedback position exceeded the value set in the Following error window (6065h) in the motor output shaft. A load is large. The acceleration/deceleration time or the acceleration/deceleration rate is too short for the load. 	<ul style="list-style-type: none"> Reduce the load. Increase the acceleration/deceleration time or slow the acceleration/deceleration rate. Reconsider the torque limiting value. Reconsider the operation data. 	Any of reset operations
20h	5	Overcurrent	The motor, the cable, and the driver output circuit were short-circuited.	Turn off the main power supply and the control power supply, and check that the motor, the cable, and the driver are not damaged. After that, turn on the main power supply and the control power supply again. If the alarm is still not reset, the motor, the cable, or the driver may be damaged. Contact your nearest Oriental Motor sales office.	Turn on the control power supply again
21h	2	Main circuit overheat	The internal temperature of the driver reached the upper limit of the specification value.	Reconsider the ventilation condition.	Any of reset operations
22h	3	Overvoltage	<ul style="list-style-type: none"> The main power supply voltage exceeded the permissible value. A large load inertia was suddenly stopped. Vertical operation (elevating operation) was performed. 	<ul style="list-style-type: none"> Check the input voltage of the main power supply. Reduce the load. Increase the acceleration/deceleration time or slow the acceleration/deceleration rate. Connect the Oriental Motor regeneration resistor RGB200. 	Turn on the control power supply again
23h	3	Main power supply OFF	The main power supply was shut off during operation.	Check if the main power supply is properly supplied.	Any of reset operations

Alarm code	Number of times LED blinks	Alarm type	Cause	Remedial action	How to reset
25h	3	Undervoltage	The main power supply was shut off momentarily or the voltage became low.	Check the input voltage of the main power supply.	Any of reset operations
26h	8	Motor overheat	The detection temperature of the ABZO sensor reached the upper limit of the specification value.	<ul style="list-style-type: none"> • Check the heat radiation condition of the motor. • Reconsider the ventilation condition. 	Any of reset operations
28h	8	Sensor error	An error of the ABZO sensor was detected during operation.	Turn off the main power supply and the control power supply, and check the connection of the motor. After that, turn on the main power supply and the control power supply again.	Turn on the control power supply again
2Ah	8	ABZO sensor communication error	An error occurred between the driver and the ABZO sensor.	Turn off the main power supply and the control power supply, and check the connection of the ABZO sensor. After that, turn on the main power supply and the control power supply again.	Turn on the control power supply again
30h	2	Overload	The motor output power reached the load factor to detect the overload alarm. Refer to p.203 for details.	<ul style="list-style-type: none"> • Reduce the load. • Increase the acceleration/ deceleration time or slow the acceleration/deceleration rate. • Check if the motor power line is disconnected. 	Any of reset operations
31h	2	Overspeed	The feedback speed of the motor output shaft exceeded the specification value.	<ul style="list-style-type: none"> • Reconsider the Electronic gear (6091h-01h, 02h) and set the speed of the motor output shaft to a value lower than the specification value. • If an overshoot is occurred at the time of accelerating, increase the acceleration time or slow the acceleration rate. 	Any of reset operations
33h	7	Absolute position error	The home information of the ABZO sensor was damaged.	Perform position preset (P-PRESET) or return-to-home operation to set the home again.	Turn on the control power supply again
34h	2	Command position error	<ul style="list-style-type: none"> • The operating speed exceeded the permissible value of the driver. • When the driver exceeded the wrap range in the Cyclic synchronous position mode, the deviation between the target position command from the MainDevice and the command position of the driver exceeded the specification value. • Position preset (P-PRESET) of the driver was executed in the Cyclic synchronous position mode when the motor was in an excitation state. 	<ul style="list-style-type: none"> • Reduce the operating speed. • When the driver performs operation that exceeds the wrap range in the Cyclic synchronous position mode, set the position control range of the MainDevice according to the wrap range. • Put the motor in a non-excitation state before executing position preset (P-PRESET) of the driver in the Cyclic synchronous position mode. 	Any of reset operations
41h	9	EEPROM error	The data stored in the driver was damaged.	Initialize all parameters.	Turn on the control power supply again

Alarm code	Number of times LED blinks	Alarm type	Cause	Remedial action	How to reset
42h	8	Sensor error at power-on	An error of the ABZO sensor was detected when the control power supply was turned on.	Turn off the main power supply and the control power supply, and check the connection of the ABZO sensor. After that, turn on the main power supply and the control power supply again.	Turn on the control power supply again
43h	8	Rotation error at power on	The motor was being rotated when the control power supply was turned on.	Reconsider the load conditions so that the output shaft does not rotate by an external force when the control power supply is turned on.	Turn on the control power supply again
44h	8	Encoder EEPROM error	The data stored in the ABZO sensor was damaged.	Execute one of the following operations. If the same alarm is still generated, the ABZO sensor has been damaged. Contact your nearest Oriental Motor sales office. <ul style="list-style-type: none"> • Set phase Z again again with the ZSG-PRESET (40D1h) of the maintenance command. • Execute the Clear tripmeter (40CFh) of the maintenance command. 	Turn on the control power supply again
45h	8	Motor combination error	A motor that is not compatible with the driver was connected.	Check the motor model and the driver model, and connect them in a correct combination.	Turn on the control power supply again
4Ah	7	Return-to-home incomplete	Absolute positioning operation was started in a state where the coordinates were not set.	<ul style="list-style-type: none"> • Reconsider the setting of the Permission of absolute positioning without setting absolute coordinates (4148h). • Execute position preset (P-PRESET) or return-to-home operation. 	Any of reset operations
4Ch	7	Network initialization error	An error was detected during initialization of the EtherCAT module.	Turn on the control power supply again. If the alarm still cannot be cleared, contact your nearest Oriental Motor sales office.	Turn on the control power supply again
51h	2	Regeneration resistor overheat	<ul style="list-style-type: none"> • The regeneration resistor RGB200 is not connected properly. • The regeneration resistor RGB200 was overheated extraordinarily. • The driver heat sink was overheated abnormally. 	<ul style="list-style-type: none"> • If the regeneration resistor RGB200 is not used, short the TH1 and TH2 terminals of the CN1 connector. • Connect the regeneration resistor RGB200 properly. • The allowable regenerative power of the regeneration resistor RGB200 is exceeded. Reconsider the load and operating conditions. • Check if the operating sound of the fan can be heard from the driver in a state where the control power supply is turned on. The fan may stop if the operating sound cannot be heard. Contact your nearest Oriental Motor sales office. 	Turn on the control power supply again

Alarm code	Number of times LED blinks	Alarm type	Cause	Remedial action	How to reset
53h	2	HWTO input circuit error	<ul style="list-style-type: none"> An amount of time after either the HWTO1 input or the HWTO2 input is turned OFF until the other input is turned OFF exceeded the value set in the HWTO delay time of checking dual system (4191h). An error of the circuit corresponding to the phenomenon above was detected. 	<ul style="list-style-type: none"> Increase the value set in the HWTO delay time of checking dual system (4191h). Check the wiring of the HWTO1 input and the HWTO2 input. 	Turn on the control power supply again
60h	7	±LS both sides active	<ul style="list-style-type: none"> When the FW-LS/RV-LS input action (4701h) is set to "2: Immediate stop with alarm" or "3: Deceleration stop with alarm," both the FW-LS input and the RV-LS input were detected. Return-to-home operation was executed in a state where both the FW-LS input and the RV-LS input were detected. 	Check the sensor logic installed and the "Inverting mode" parameter.	Any of reset operations
61h	7	Reverse ±LS connection	The LS input opposite to the operating direction was detected while return-to-home operation in the 2-sensor mode or the 3-sensor mode was performed.	Check the wiring of the sensor.	Any of reset operations
62h	7	Return-to-home operation error	<ul style="list-style-type: none"> An unanticipated load was applied while return-to-home operation was performed. The installation positions of the FW-LS and RV-LS sensors and the HOME sensor are near to each other. Position preset (P-PRESET) processing upon completion of return-to-home operation was failed. In return-to-home operation in the one-way rotation mode, the HOME sensor was exceeded while the motor decelerated to a stop. 	<ul style="list-style-type: none"> Check the load. Reconsider the sensor installation positions and the starting direction of motor operation. See that a load exceeding the maximum torque is not applied upon completion of return-to-home operation. Reconsider the specifications of the HOME sensor and the Homing acceleration (609Ah). 	Any of reset operations
63h	7	No HOMES	The HOMES input was not detected at a position between the FW-LS input and the RV-LS input while return-to-home operation in the 3-sensor mode was performed.	Install the HOME sensor at a position between the FW-LS and RV-LS sensors.	Any of reset operations

Alarm code	Number of times LED blinks	Alarm type	Cause	Remedial action	How to reset
64h	7	ZSG, SLIT signal error	The ZSG output and the SLIT input could not be detected during return-to-home operation.	<ul style="list-style-type: none"> Reconsider the connection status of the load and the position of the HOME sensor so that these signals should be ON while the HOMES input is ON. If the signals are not used, set the (HOME) Return-to-home ZSG signal detection (4167h) or the (HOME) Return-to-home SLIT detection (4166h) to "0: Disable." 	Any of reset operations
66h	7	Hardware overtravel	When the FW-LS/RV-LS input action (4701h) is set to "2: Immediate stop with alarm" or "3: Deceleration stop with alarm," the FW-LS input or the RV-LS input was detected.	<ul style="list-style-type: none"> Reconsider the operation data. After resetting the alarm, operate the motor in the opposite direction to escape from the sensor. The operation can be performed in any of operation modes. Reset the alarm and then escape from the sensor manually. 	Any of reset operations
67h	7	Software overtravel	When the Software overtravel (41C3h) is set to "2: Immediate stop with alarm" or "3: Deceleration stop with alarm," the motor position reached the set value of the software limit.	<ul style="list-style-type: none"> Reconsider the operation data. After resetting the alarm, operate the motor in the opposite direction to escape from the sensor. The operation can be performed in any of operation modes. Reset the alarm and then escape from the sensor manually. 	Any of reset operations
68h	1	HWTO input detection	When the HWTO mode selection (4190h) is set to "1: Alarm is present," the HWTO1 input or the HWTO2 input was turned OFF.	Turn the HWTO1 input and the HWTO2 input ON.	Any of reset operations
6Ah	7	Return-to-home operation offset error	When offset movement as part of return-to-home operation was performed, the FW-LS input or the RV-LS input was detected.	Check the offset value.	Any of reset operations
6Dh	7	Mechanical overtravel	The product having set the home reached the mechanism limit stored in the ABZO sensor.	<ul style="list-style-type: none"> Check the travel amount (position). Reset the alarm and then escape from the sensor by operating the motor or manually. 	Any of reset operations
70h	7	Operation data error	<ul style="list-style-type: none"> Operation was performed at the operating speed exceeding the value set in the Mechanism protection parameter (47F4h). Wrap operation was executed when the Wrap (RND) setting (41C7h) was disabled. 	<ul style="list-style-type: none"> Check the operation data. Check the setting for the Mechanism protection parameter (47F4h) using the unit information monitor of the MEXE02 software. Check the wrap setting. 	Any of reset operations

Alarm code	Number of times LED blinks	Alarm type	Cause	Remedial action	How to reset
71h	7	Electronic gear setting error	The resolution set in the Electronic gear (6091h-01h, 02h) was out of the specification.	Reconsider the Electronic gear (6091h-01h, 02h), and set so that the resolution should be in the range of the specifications.	Turn on the control power supply again
72h	7	Wrap setting error	The control power supply was turned on in a state where the resolution set in the Electronic gear (6091h-01h, 02h) and the value set in the Wrap (RND) setting (41C7h) were inconsistent.	Perform the wrap setting properly, and turn on the control power supply again.	Turn on the control power supply again
81h	7	Network bus error	<ul style="list-style-type: none"> A communication error of EtherCAT was detected during operation. The EtherCAT State Machine (ESM) was transitioned to other than Operational during operation. 	Check the conditions of the connector, the cable, and the MainDevice of EtherCAT.	Any of reset operations
82h	7	Network module error	An error was detected in the network module.	Turn on the control power supply again.	Turn on the control power supply again
F0h	Light	CPU error	CPU malfunctioned.	Turn on the control power supply again.	Turn on the control power supply again

Related object

Index	Sub	Name	Type	Access	PDO	Save	Initial value	Range	Update
6065h	00h	Following error window	U32	RW	No	○	300	1 to 30,000 (1=0.01 rev)	A

■ Characteristics of overload alarm

The time when the overload alarm is detected varies depending on the load factor.

Load factor (%)	Overload alarm detection time
100	Not detected
125	About 10 s
150	About 4 s
250	About 1 s
300	About 0.5 s
375	About 0.3 s

- Overload alarm detection time (reference)

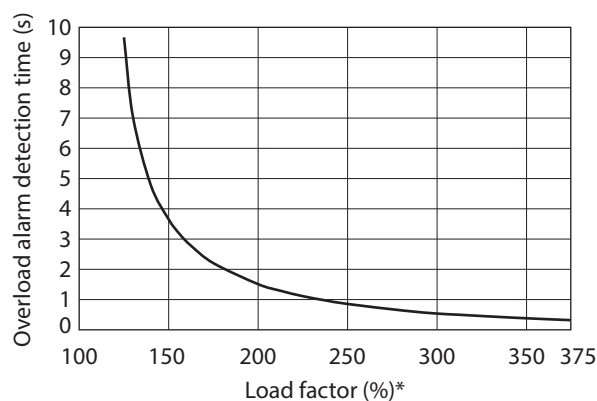

- * This indicates the motor output power presently generated as a percentage of the maximum output power in the continuous duty region.

1-5 Timing chart

1. If an error occurs, the ALM-B output, the MOVE output, and the DCMD-RDY output are turned OFF. At the same time, the motor stops to go into a non-excitation state.
2. Remove the cause of the alarm before turning the ALM-RST input ON. The alarm is reset, and the ALM-B output is turned ON. If the excitation command is input from the EtherCAT MainDevice, the motor goes into an excitation state at the same time as the alarm is reset, and the READY output and the DCMD-RDY output are turned ON.



If an alarm is generated during operation, execute an operation stop from the MainDevice before resetting the alarm. In the Cyclic synchronous position mode (CSP), clear the position deviation between the EtherCAT MainDevice and the driver after the operation is stopped. Otherwise, the motor may suddenly start, causing injury or damage to equipment.

3. Check that the ALM-B output has been turned ON, and then turn the ALM-RST input OFF.

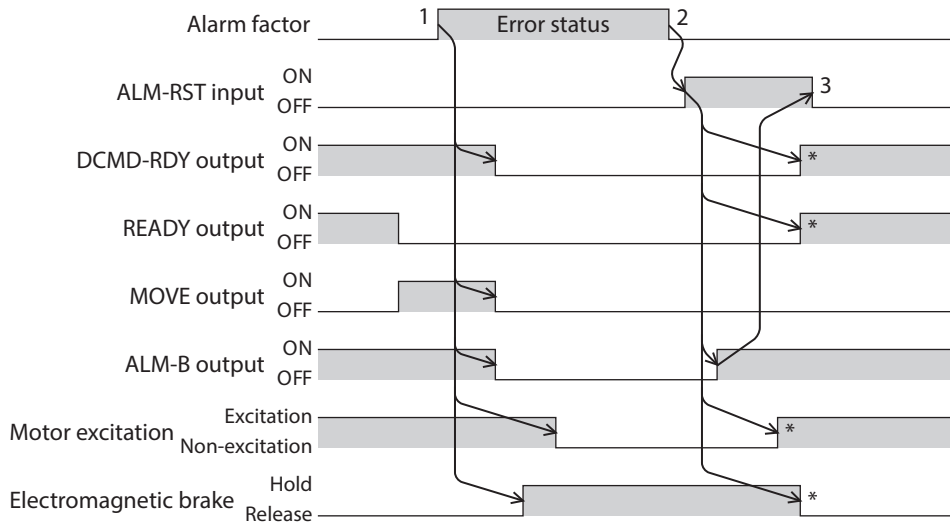

* It is the movement when the excitation command is input from the EhterCAT MainDevice at the time the ALM-RST input is turned ON.

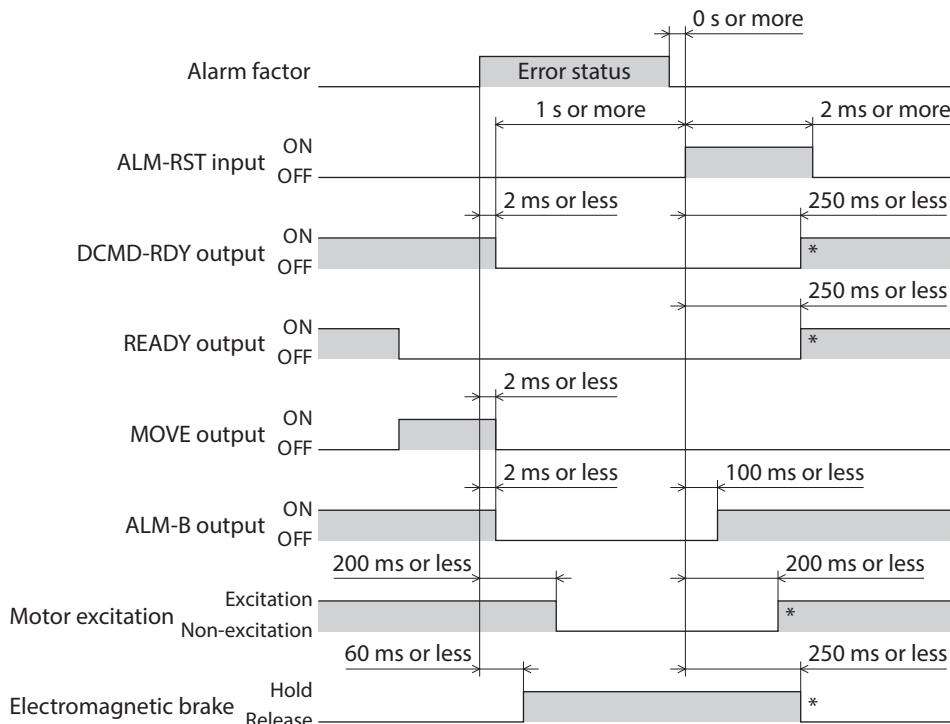

* It is the movement when the excitation command is input from the EhterCAT MainDevice at the time the ALM-RST input is turned ON.

2 Information

The driver is equipped with a function to generate information output before an alarm is generated.

This function can be utilized for periodic maintenance of equipment by setting a suitable value in the parameter of each information.

For example, using the Motor temperature information (41A8h) can prevent equipment malfunction or production stoppage due to motor overheating. In addition, the Tripmeter information (41AFh) can be used as a reference to perform maintenances each time a certain travel distance is reached.

■ Status when information is generated

● Information bit output

If information is generated, a bit output (INFO-** output) of the corresponding information is turned ON.

A desired output signal can be assigned to the INFO-USRIO output among bit outputs and used. If the assigned output signal is turned ON, the INFO-USRIO output is also turned ON. For details about bit output, refer to p.207.

● INFO output

If information is generated, the INFO output is turned ON.

● LED indicator

If information is generated, the PWR/ALM LED will simultaneously blink in red and green twice. (Red and green colors may overlap and it may be visible to orange.)

● Motor operation

The motor continues to operate during information unlike in the case of an alarm.

● Parameters

Each information has a corresponding "INFO action" parameter. If the parameter is set to "0: Only bit output is turned ON," only the bit output of information is turned ON, and the INFO output and LED are not changed.

Related objects

Index	Sub	Name	Type	Access	PDO	Save	Range	Initial value	Update
41A0h	00h	Driver temperature information (INFO-DRVTMP)	INT16	RW	RxPDO	○	40 to 85 °C	85	A
41A1h	00h	Torque limiting time information (INFO-TLCTIME)	INT16	RW	RxPDO	○	0: Disable 1 to 10,000 ms	0	A
41A2h	00h	Speed information (INFO-SPD)	INT16	RW	RxPDO	○	0: Disable 1 to 12,000 r/min	0	A
41A5h	00h	Position deviation information (INFO-POSERR)	INT16	RW	RxPDO	○	1 to 30,000 (1=0.01 rev)	300	A
41A6h	00h	Load factor information (INFO-LOAD)	U16	RW	RxPDO	○	0: Disable 1 to 10,000 (1=0.1 %)	0	A
41A7h	00h	Torque information (INFO-TRQ)	U16	RW	RxPDO	○	0: Disable 1 to 10,000 (1=0.1 %)	0	A
41A8h	00h	Motor temperature information (INFO-MTRTMP)	INT16	RW	RxPDO	○	40 to 120 °C	85	A
41A9h	00h	Overvoltage information (INFO-OVOLT)	INT16	RW	RxPDO	○	120 to 450 V	400	A
41AAh	00h	Undervoltage information (INFO-UVOLT)	INT16	RW	RxPDO	○	120 to 280 V	120	A
41AFh	00h	Tripmeter information (INFO-TRIP)	INT32	RW	RxPDO	○	0: Disable 1 to 2,147,483,647 (1=0.1 kRev)	0	A
41B0h	00h	Odometer information (INFO-ODO)	INT32	RW	RxPDO	○	0: Disable 1 to 2,147,483,647 (1=0.1 kRev)	0	A
41B1h	00h	Cumulative load 0 information (INFO-CULD0)	INT32	RW	RxPDO	○	0 to 2,147,483,647	0	A
41B2h	00h	Cumulative load 1 information (INFO-CULD1)	INT32	RW	RxPDO	○	0 to 2,147,483,647	0	A

Index	Sub	Name	Type	Access	PDO	Save	Range	Initial value	Update
41B3h	00h	Cumulative load value auto clear	U8	RW	No	<input type="radio"/>	0: Disable 1: Enable	1	A
41B4h	00h	Cumulative load value count divisor	U16	RW	No	<input type="radio"/>	1 to 32,767	1	A
41B5h	00h	Settling time information (INFO-STLTIME)	U16	RW	RxPDO	<input type="radio"/>	0: Disable 1 to 10,000 ms	0	A
41BCCh	00h	INFO-USRIO output selection	U8	RW	No	<input type="radio"/>	Output signal ⇔ p.116	128	A
41BDh	00h	INFO-USRIO output inversion	U8	RW	No	<input type="radio"/>	0: Non invert 1: Invert	0	A
41BEh	00h	Information LED condition	U8	RW	No	<input type="radio"/>	0: Disable (LED does not blink) 1: Enable (LED blinks)	1	A
41BFh	00h	Information auto clear	U8	RW	No	<input type="radio"/>	0: Disabled (not turned OFF automatically) 1: Enabled (turned OFF automatically)	1	A
47A0h	00h	INFO action (Assigned I/O status information (INFO-USRIO))	U8	RW	No	<input type="radio"/>	0: Only the bit output is ON 1: The bit output and the INFO output are ON and the LED blinks	1	A
47A1h	00h	INFO action (Position deviation information (INFO-POSERR))	U8	RW	No	<input type="radio"/>			A
47A2h	00h	INFO action (Driver temperature information (INFO-DRVTMP))	U8	RW	No	<input type="radio"/>			A
47A3h	00h	INFO action (Motor temperature information (INFO-MTRTMP))	U8	RW	No	<input type="radio"/>			A
47A4h	00h	INFO action (Overvoltage information (INFO-OVOLT))	U8	RW	No	<input type="radio"/>			A
47A5h	00h	INFO action (Undervoltage information (INFO-UVOLT))	U8	RW	No	<input type="radio"/>			A
47A6h	00h	INFO action (Torque limiting time information (INFO-TLCTIME))	U8	RW	No	<input type="radio"/>			A
47A7h	00h	INFO action (Load factor information (INFO-LOAD))	U8	RW	No	<input type="radio"/>			A
47A8h	00h	INFO action (Speed information (INFO-SPD))	U8	RW	No	<input type="radio"/>			A
47A9h	00h	INFO action (Start operation error information (INFO-START))	U8	RW	No	<input type="radio"/>			A
47AAh	00h	INFO action (Start ZHOME error information (INFO-ZHOME))	U8	RW	No	<input type="radio"/>			A
47ABh	00h	INFO action (PRESET request information (INFO-PR-REQ))	U8	RW	No	<input type="radio"/>			A
47ADh	00h	INFO action (Electronic gear setting error information (INFO-EGR-E))	U8	RW	No	<input type="radio"/>			A
47AEh	00h	INFO action (Wrap setting error information (INFO-RND-E))	U8	RW	No	<input type="radio"/>			A
47B0h	00h	INFO action (Forward operation prohibition information (INFO-FW-OT))	U8	RW	No	<input type="radio"/>			A
47B1h	00h	INFO action (Reverse operation prohibition information (INFO-RV-OT))	U8	RW	No	<input type="radio"/>			A
47B2h	00h	INFO action (Cumulative load 0 information (INFO-CULD0))	U8	RW	No	<input type="radio"/>	A		

Index	Sub	Name	Type	Access	PDO	Save	Range	Initial value	Update
47B3h	00h	INFO action (Cumulative load 1 information (INFO-CULD1))	U8	RW	No	<input type="radio"/>	0: Only the bit output is ON 1: The bit output and the INFO output are ON and the LED blinks	1	A
47B4h	00h	INFO action (Tripmeter information (INFO-TRIP))	U8	RW	No	<input type="radio"/>			A
47B5h	00h	INFO action (Odometer information (INFO-ODO))	U8	RW	No	<input type="radio"/>			A
47B7h	00h	INFO action (Torque information (INFO-TRQ))	U8	RW	No	<input type="radio"/>			A
47B8h	00h	INFO action (Settling time information (INFO-STLTIME))	U8	RW	No	<input type="radio"/>			A
47BCh	00h	INFO action (Start operation restricted mode information (INFO-DSLMTD))	U8	RW	No	<input type="radio"/>			A
47BDh	00h	INFO action (I/O test mode information (INFO-IOTEST))	U8	RW	No	<input type="radio"/>			A
47BEh	00h	INFO action (Configuration request information (INFO-CFG))	U8	RW	No	<input type="radio"/>			A
47BFh	00h	INFO action (Reboot request information (INFO-RBT))	U8	RW	No	<input type="radio"/>			A

2-1 Information history

Up to 16 generated information items are stored in the RAM in order of the latest to the oldest. Information items stored as the information history are the information code, generation time, and contents of information.

The information history can be read or cleared when any of the following is performed.

- Read the information history by the Information history (4510h to 451Fh) of EtherCAT.
- Clear the information history by setting the Clear information history (40D4h) of EtherCAT to 1. (It is enabled when changing from 0 to 1.)
- Read or clear the information history using the **MEXE02** software.



Information history is stored in the RAM, so they are cleared when the control power supply of the driver is turned off.

2-2 Information list

Information item	Information bit output signal	Cause	Clear condition
Assigned I/O status	INFO-USRIO	The I/O signal set in the INFO-USRIO output selection (41BCh) was turned ON.	The I/O signal set in the INFO-USRIO output selection (41BCh) was turned OFF.
Position deviation	INFO-POSERR	The deviation between the command position and the feedback position exceeded the value set in the Position deviation information (41A5h) in the motor output shaft.	The deviation between the command position and the feedback position fell below the value set in the Position deviation information (41A5h) in the motor output shaft.
Driver temperature	INFO-DRVTMP	The internal temperature of the driver exceeded the value set in the Driver temperature information (41A0h).	The internal temperature of the driver fell below the value set in the Driver temperature information (41A0h).
Motor temperature	INFO-MTRTMP	The detection temperature of the encoder exceeded the value set in the Motor temperature information (41A8h).	The detection temperature of the encoder fell about 5 °C (9 °F) below the value set in the Motor temperature information (41A8h).

Information item	Information bit output signal	Cause	Clear condition
Overvoltage	INFO-OVOLT	<ul style="list-style-type: none"> The voltage of the main power supply exceeded the value set in the Overvoltage information (41A9h). A large load inertia was suddenly stopped. Vertical operation (elevating operation) was performed. 	The voltage of the main power supply fell below the value set in the Overvoltage information (41A9h).
Undervoltage	INFO-UVOLT	<ul style="list-style-type: none"> The voltage of the main power supply fell below the value set in the Undervoltage information (41AAh). The main power supply was shut off momentarily or the voltage became low. 	The voltage of the main power supply exceeded the value set in the Undervoltage information (41AAh).
Torque limiting time	INFO-TLCTIME	The ON time of the TLC output exceeded the value set in the Torque limiting time information (41A1h).	The TLC input was turned OFF.
Load factor	INFO-LOAD	The load factor of the motor exceeded the value set in the Load factor information (41A6h).	The load factor of the motor fell below the value set in the Load factor information (41A6h).
Speed	INFO-SPD	The feedback speed of the motor exceeded the value set in the Speed information (41A2h).	The feedback speed of the motor fell below the value set in the Speed information (41A2h).
Start operation error	INFO-START	<ul style="list-style-type: none"> Operation in the direction having stopped by the FW-BLK input or the RV-BLK input was started. Operation in the direction having stopped by the FW-LS input or the RV-LS input was started. Operation in the direction having stopped by the software limit was started. When operation could not be executed (example: the READY output was OFF), the operation start signal was turned ON. 	Operation was started properly.
Start ZHOME error	INFO-ZHOME	When the coordinates were not set (the ABSPEN output was OFF), high-speed return-to-home operation was started.	Operation was started normally.
Preset request	INFO-PR-REQ	Preset was executed by position preset (P-PRESET) or return-to-home operation.	Preset was completed.
Electronic gear setting error	INFO-EGR-E	The resolution set in the Electronic gear (6091h-01h, 02h) was out of specification.	The resolution was set within the specifications.
Wrap setting error	INFO-RND-E	The resolution and the Initial coordinate generation & wrap setting range (41C9h) were inconsistent.	The Initial coordinate generation & wrap setting range (41C9h) was set within the specifications.
Forward operation prohibition	INFO-FW-OT	<ul style="list-style-type: none"> The positive software limit was exceeded. Either the FW-LS input or the FW-BLK input was turned ON. 	The position of the motor fell into the range of the positive software limit, and additionally, both the FW-LS input and the FW-BLK input were turned OFF.
Reverse operation prohibition	INFO-RV-OT	<ul style="list-style-type: none"> The negative software limit was exceeded. Either the RV-LS input or the RV-BLK input was turned ON. 	The position of the motor fell into the range of the negative software limit, and additionally, both the RV-LS input and the RV-BLK input were turned OFF.
Cumulative load 0	INFO-CULD0	The cumulative load exceeded the value set in the Cumulative load 0 information (41B1h).	The cumulative load fell below the value set in the Cumulative load 0 information (41B1h).
Cumulative load 1	INFO-CULD1	The cumulative load exceeded the value set in the Cumulative load 1 information (41B2h).	The cumulative load fell below the value set in the Cumulative load 1 information (41B2h).

Information item	Information bit output signal	Cause	Clear condition
Tripmeter	INFO-TRIP	The travel distance of the motor exceeded the value set in the Tripmeter information (41AFh).	After one of the following operations was performed, the travel distance (Tripmeter) of the motor fell below the value set in the Tripmeter information (41AFh). <ul style="list-style-type: none"> • The Tripmeter information (41AFh) was set again. • The Clear tripmeter (40CFh) of the maintenance command was executed.
Odometer	INFO-ODO	The cumulative travel distance of the motor exceeded the value set in the Odometer information (41B0h).	After the following operation was performed, the cumulative travel distance (Odometer) of the motor fell below the value set in the Odometer information (41B0h). <ul style="list-style-type: none"> • The Odometer information (41B0h) was set again.
Torque	INFO-TRQ	The detection torque of the motor exceeded the value set in the Torque information (41A7h).	The detection torque of the motor fell below the value set in the Torque information (41A7h).
Settling time	INFO-STLTIME	The settling time exceeded the value set in the Settling time information (41B5h).	<ul style="list-style-type: none"> • Operation was started. • The settling time fell below the value set in the Settling time information (41B5h).
Start operation restricted mode	INFO-DSLMTD	<ul style="list-style-type: none"> • Configuration was executed. • "Remote operation" was executed with the MEXE02 software. • Data was written from the MEXE02 software to the driver. • "Restore to factory settings" was executed with the MEXE02 software. 	<ul style="list-style-type: none"> • Configuration was completed. • Remote operation was canceled. • Writing data was completed. • Data was restored to the factory setting.
I/O test mode	INFO-IOTEST	<ul style="list-style-type: none"> • Configuration was executed. • "I/O test" was executed with the MEXE02 software. 	<ul style="list-style-type: none"> • Configuration was completed. • The I/O test mode was canceled.
Configuration request	INFO-CFG	Configuration was requested to execute.	Configuration was executed.
Reboot request	INFO-RBT	Reboot was requested.	Reboot was executed.



If the "Preset request" information was generated for 100 ms or more in a state where the Information auto clear (41BFh) was set to disable, the preset may have been failed. There are the following two possible reasons the preset was failed.

- The ABZO sensor is not connected to the driver.
- Preset was executed in a state where the position deviation between the command position and the actual position was 1.8 degrees or more.

■ Monitor of information

Details of information can be checked with the Information (407Bh).

The information code having read is indicated in 8-digit hexadecimal number. It can also be read in 32 bits. If multiple information items are generated, the logical sum (OR) of the information codes is indicated.

Information code	32 bits indication	Information item	Output signal
00000001h	0000 0000 0000 0000 0000 0000 0000 0001	I/O (User setting)	INFO-USRIO
00000002h	0000 0000 0000 0000 0000 0000 0000 0010	Position deviation	INFO-POSERR
00000004h	0000 0000 0000 0000 0000 0000 0000 0100	Driver temperature	INFO-DRVTMP
00000008h	0000 0000 0000 0000 0000 0000 0000 1000	Motor temperature	INFO-MTRTMP
00000010h	0000 0000 0000 0000 0000 0000 0001 0000	Overvoltage	INFO-OVOLT
00000020h	0000 0000 0000 0000 0000 0000 0010 0000	Undervoltage	INFO-UVOLT
00000040h	0000 0000 0000 0000 0000 0000 0100 0000	Torque limiting time	INFO-TLCTIME
00000080h	0000 0000 0000 0000 0000 0000 1000 0000	Load factor	INFO-LOAD
00000100h	0000 0000 0000 0000 0000 0001 0000 0000	Speed	INFO-SPD
00000200h	0000 0000 0000 0000 0000 0010 0000 0000	Start operation error	INFO-START
00000400h	0000 0000 0000 0000 0000 0100 0000 0000	Start ZHOME error	INFO-ZHOME
00000800h	0000 0000 0000 0000 0000 1000 0000 0000	Preset request	INFO-PR-REQ
00002000h	0000 0000 0000 0000 0010 0000 0000 0000	Electronic gear setting error	INFO-EGR-E
00004000h	0000 0000 0000 0000 0100 0000 0000 0000	Wrap setting error	INFO-RND-E
00010000h	0000 0000 0000 0001 0000 0000 0000 0000	Forward operation prohibition	INFO-FW-OT
00020000h	0000 0000 0000 0010 0000 0000 0000 0000	Reverse operation prohibition	INFO-RV-OT
00040000h	0000 0000 0000 0100 0000 0000 0000 0000	Cumulative load 0	INFO-CULDO
00080000h	0000 0000 0000 1000 0000 0000 0000 0000	Cumulative load 1	INFO-CULD1
00100000h	0000 0000 0001 0000 0000 0000 0000 0000	Tripmeter	INFO-TRIP
00200000h	0000 0000 0010 0000 0000 0000 0000 0000	Odometer	INFO-ODO
00800000h	0000 0000 1000 0000 0000 0000 0000 0000	Torque	INFO-TRQ
01000000h	0000 0001 0000 0000 0000 0000 0000 0000	Settling time	INFO-STLTIME
10000000h	0001 0000 0000 0000 0000 0000 0000 0000	Start operation restricted mode	INFO-DSLMTD
20000000h	0010 0000 0000 0000 0000 0000 0000 0000	I/O test mode	INFO-IOTEST
40000000h	0100 0000 0000 0000 0000 0000 0000 0000	Configuration request	INFO-CFG

Information code	32 bits indication	Information item	Output signal
80000000h	1000 0000 0000 0000 0000 0000 0000 0000	Reboot request	INFO-RBT

3 Troubleshooting and remedial actions

In motor operation, the motor or the driver may not operate properly due to an improper setting or incorrect connection.

When the motor cannot be operated properly, refer to the contents provided in this chapter and take an appropriate remedial action.

If the problem persists, contact your nearest Oriental Motor sales office.

Phenomenon	Possible cause	Remedial action
<ul style="list-style-type: none"> • The motor is not excited. • The output shaft can be rotated by hand. 	Connection error of the motor cable	Check the motor connection.
	The FREE input is being ON.	Turn the FREE input OFF.
The motor does not rotate.	When an electromagnetic brake motor is used, the electromagnetic brake is in a state of holding the motor shaft.	Check the connection of the electromagnetic brake.
	The STOP input is being ON.	Turn the STOP input OFF.
The motor rotates in the direction opposite to the specified direction.	The Motor rotation direction (41C2h) is set wrongly.	Check the setting of the Motor rotation direction (41C2h).
Motor operation is unstable.	Connection error of the motor cable or power supply cable.	Check the connections for the driver, the motor, and the main power supply.
The electromagnetic brake is not put into a state of releasing the motor shaft.	The power is not supplied to the electromagnetic brake.	Check the connection of the electromagnetic brake.

 When the alarm is being generated, check the alarm message via EtherCAT or using the **MEXE02** software.

7 Extended function

◆Table of contents

1	Gain tuning	214
1-1	Setting of load inertia	214
1-2	Setting of motor response	214
2	Vibration suppression	217
2-1	Command filter	217
2-2	Resonance suppression.....	218
2-3	Damping control.....	219
2-4	Electronic damper function	219
3	Cumulative load	220
4	Load factor monitor	222
5	Changing the function of the HOME PRESET switch	223
6	Simulating the driver operation	224
6-1	Preparation and operating procedure for driver simulation mode	225
6-2	Coordinates.....	226
6-3	Monitor.....	227
6-4	Operation	228
6-5	I/O signals.....	228
6-6	Alarms.....	228
7	Using general signals	229



1 Gain tuning

The motor response in reaction to the command can be adjusted according to the load inertia and the mechanical rigidity.

1-1 Setting of load inertia

This is used to set the load inertia according to the load inertia of equipment.

Related parameters

MEXE02 code	Name	Description	Setting range	Initial value
p11	Load inertia setting mode selection	Selects the setting method of the load inertia.	0: "Load inertia setting" parameter is used 1: Automatic	1
	Load inertia setting	Sets the ratio of the load inertia to the motor rotor inertia. When the rotor inertia is equal to the load inertia, the ratio is 100 %.	0 to 10,000 %	0

1-2 Setting of motor response

This is used to set the motor response in reaction to the command.

Related parameter

MEXE02 code	Name	Description	Setting range	Initial value
p11	Motor response setting	Selects the setting method of the motor response in reaction to the command of the driver.	-1: Manual setting 0 to 15	6

■ When the "Motor response setting" parameter is set to "-1: Manual setting"

The related parameters are enabled only when the "Motor response setting" parameter is set to "-1: Manual setting."

Related parameters

MEXE02 code	Name	Description	Setting range	Initial value
p11	Position loop gain	Adjusts the motor response in reaction to the position deviation. Increasing the value will make the deviation between the command position and the actual position smaller. An excessively large value may increase the motor overshoot or cause the motor vibration.	1 to 50 Hz	8
	Speed loop gain	Adjusts the motor response in reaction to the speed deviation. Increasing the value will make the deviation between the command speed and the actual speed smaller. An excessively large value may increase the motor overshoot or cause the motor vibration.	1 to 500 Hz	82

MEXE02 code	Name	Description	Setting range	Initial value
p11	Speed loop integral time constant	Adjusts the deviation that cannot be adjusted with the speed loop gain. An excessively long value may slow the motor response. An excessively short value may cause the motor vibration.	1 to 10,000 (1=0.01 ms)	1,940
	Torque filter (LPF)	Adjusts the motor response at high frequencies.	0 to 4,700 Hz	820
	Speed feed-forward	When the speed is constant, the deviation between the command position and the actual position can be reduced to shorten the settling time. If it is set to 100 %, the deviation will be approximately 0 %. However, an excessively high value may increase the motor overshoot or cause the motor vibration.	0 to 100 %	80
	Mechanical rigidity setting	Sets the rigidity of equipment. Although the motor response improves as the setting value increases, an excessively high value may cause the motor to vibrate or to generate noise.	0 to 15	6



In general, the order of rigidity from lowest to highest is as follows.
Belt and pulley - Rack and pinion - Ball screw - Rigid body (index table, gear, etc.)

■ When the "Motor response setting" parameter is set to "0 to 15"

When the "Motor response setting" parameter is set to "0 to 15," the setting values of the related parameters are shown in the table below.

Motor response setting	Position loop gain [Hz]	Speed loop gain [Hz]	Speed loop integral time constant [ms]	Speed feed-forward [%]	Torque filter [Hz]	Mechanical rigidity setting
0	1	14	51.00	80	300	0
1	2	22	51.00	80	300	1
2	3	32	48.20	80	320	2
3	5	46	33.80	80	460	3
4	6	56	28.40	80	560	4
5	7	68	23.40	80	680	5
6	8	82	19.40	80	820	6
7	10	100	15.80	80	1,000	7
8	12	120	13.20	80	1,200	8
9	15	150	10.60	80	1,500	9
10	18	180	8.80	80	1,800	10
11	20	220	7.20	80	2,200	11
12	20	270	5.80	80	2,700	12
13	20	330	4.80	80	3,300	13
14	20	390	4.00	80	3,900	14
15	20	470	3.40	80	4,700	15

■ Control devices block diagram (Position control)

In the figure, "+" indicates addition and "-" indicates subtraction. The description surrounded by a box (□) is the parameter name.

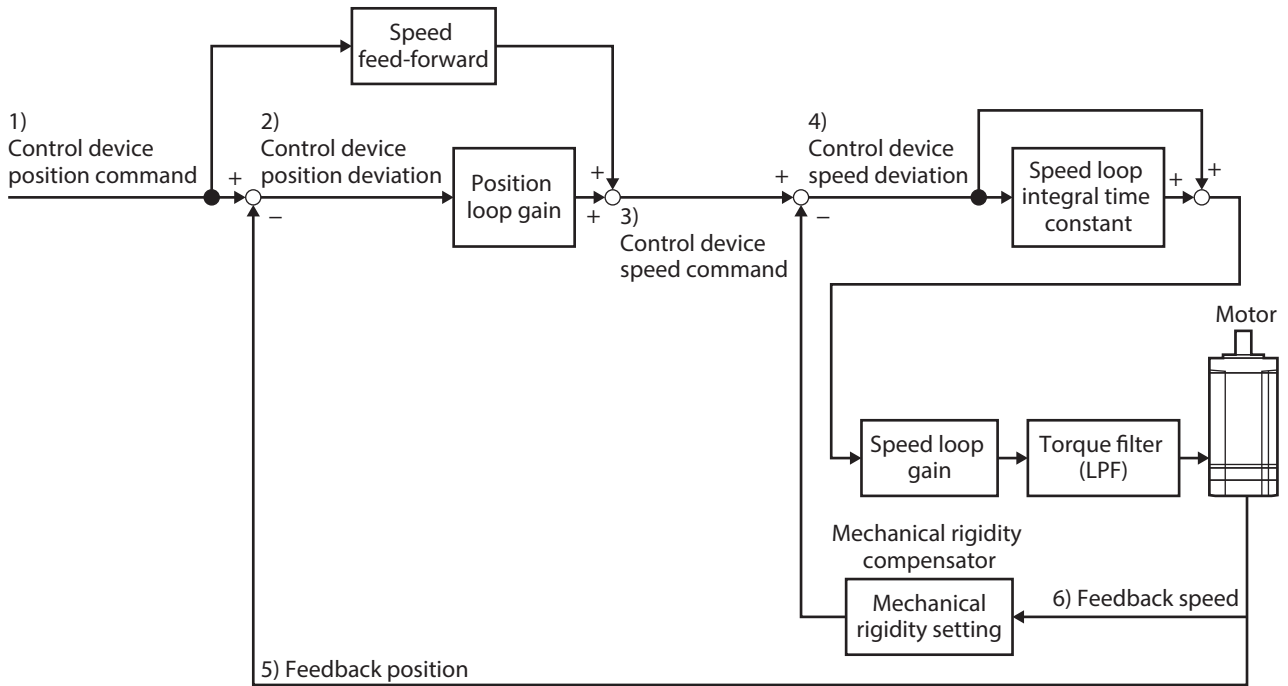

Name	Description
1) Control device position command	Indicates the command position of the control device (after command filter).
2) Control device position deviation	Indicates the position deviation of the control device (after command filter).
3) Control device speed command	Indicates the command speed of the control device (after command filter).
4) Control device speed deviation	Indicates the speed deviation of the control device (after command filter).
5) Feedback position	Indicates the feedback position.
6) Feedback speed	Indicates the feedback speed.

■ Control devices block diagram (Speed control)

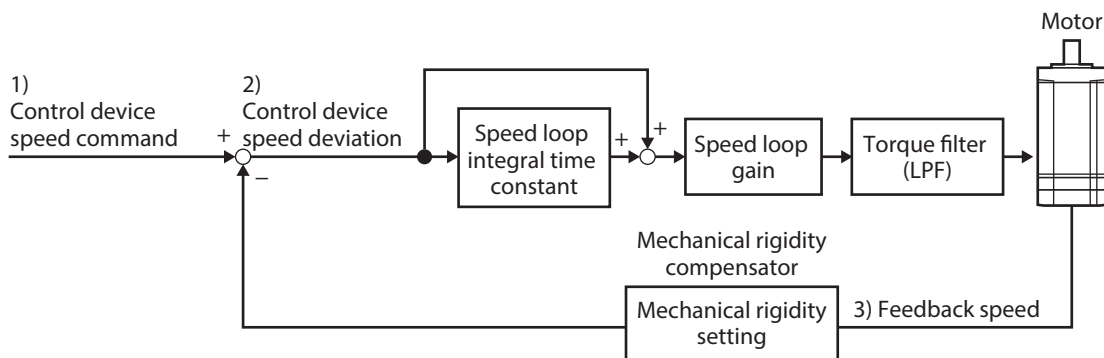

Name	Description
1) Control device speed command	Indicates the command speed of the control device (after command filter).
2) Control device speed deviation	Indicates the speed deviation of the control device (after command filter).
3) Feedback speed	Indicates the feedback speed.

2 Vibration suppression

2-1 Command filter

Using the command filter to adjust the motor response can suppress the motor vibration. There are two types of command filters, LPF (speed filter) and moving average filter.

Related parameters

MEXE02 code	Name	Description	Setting range	Initial value
P11	Command filter setting	Sets the filter function to adjust the motor response.	1: LPF (speed filter) 2: Moving average filter	1
	Command filter time constant	Adjusts the motor response.	0 to 200 ms	1



The optimal value varies depending on the equipment or operating condition. Check it under the actual conditions of use.

■ LPF (Speed filter)

Select "1: LPF (speed filter)" in the "Command filter setting" parameter, and set the "Command filter time constant" parameter.

Increasing the setting value in the "Command filter time constant" parameter can suppress the motor vibration at low speed operation and make the motor movement at starting/stopping smoother. However, setting an excessively high value reduces the synchronization performance in response to the command. Set an appropriate value according to a load or an application.

- When the "Command filter time constant" parameter is set to 0 ms

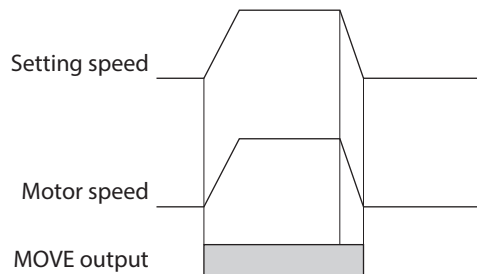

- When the "Command filter time constant" parameter is set to 200 ms

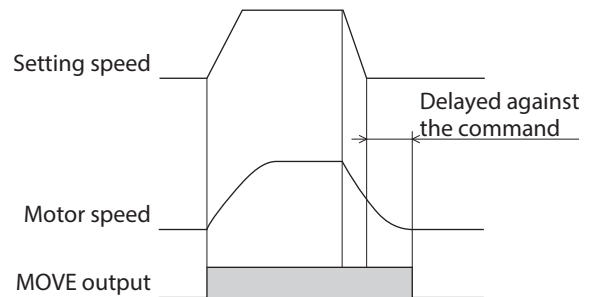

■ Moving average filter

Select "2: Moving average filter" in the "Command filter setting" parameter, and set the "Command filter time constant" parameter.

The motor response can be adjusted. In addition, the positioning time can be shortened by suppressing the residual vibration during positioning operation.

The optimal value for the "Command filter time constant" parameter varies depending on a load or operating condition. Set an appropriate value according to a load or operating condition.

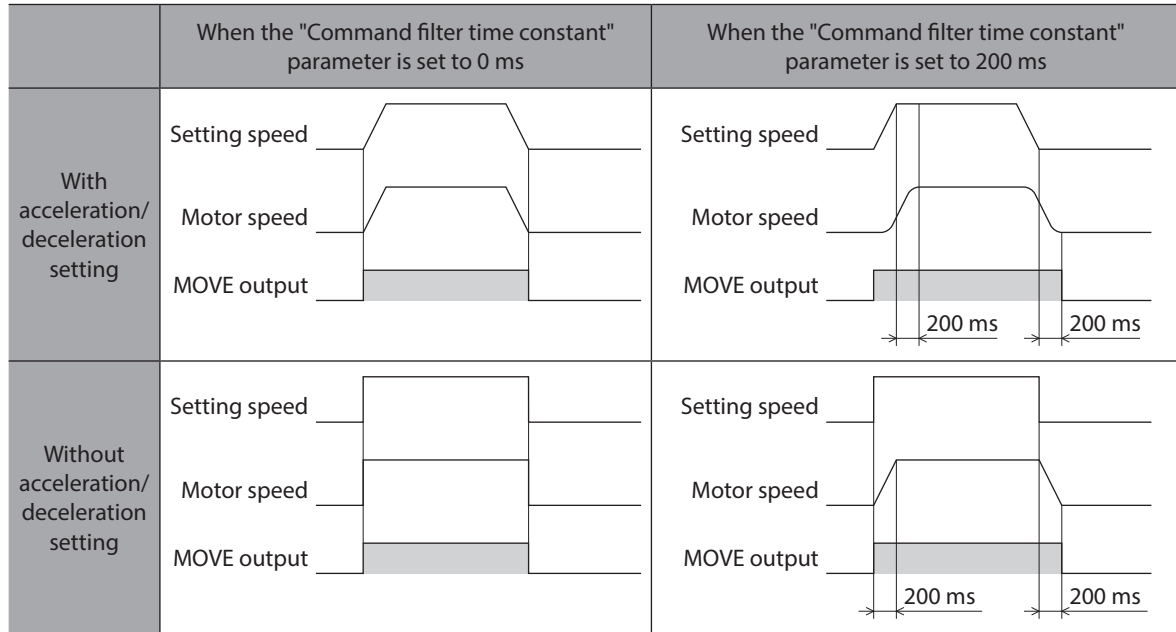

2-2 Resonance suppression

This is used to set the filter for suppressing the motor resonance.

Related parameters

MEXE02 code	Name	Description	Setting range	Initial value
p11	Resonance suppression control A frequency	Sets the frequency of vibration to be suppressed.	100 to 3,200 Hz	1,000
	Resonance suppression control A gain	Sets the gain to suppress the vibration. Increasing the value causes the motor response to the deviation to lower.	0 to 100 %	0
	Resonance suppression control A width	Sets the width of vibration to be suppressed.	30 to 120	30
	Resonance suppression control B frequency	Sets the frequency of vibration to be suppressed.	100 to 3,200 Hz	1,000
	Resonance suppression control B gain	Sets the gain to suppress the vibration. Increasing the value causes the motor response to the deviation to lower.	0 to 100 %	0
	Resonance suppression control B width	Sets the width of vibration to be suppressed.	30 to 120	30
	Resonance suppression control C frequency	Sets the frequency of vibration to be suppressed.	100 to 3,200 Hz	1,000
	Resonance suppression control C gain	Sets the gain to suppress the vibration. Increasing the value causes the motor response to the deviation to lower.	0 to 100 %	0
	Resonance suppression control C width	Sets the width of vibration to be suppressed.	30 to 120	30

MEXE02 code	Name	Description	Setting range	Initial value
p11	Resonance suppression control D frequency	Sets the frequency of vibration to be suppressed.	100 to 3,200 Hz	1,000
	Resonance suppression control D gain	Sets the gain to suppress the vibration. Increasing the value causes the motor response to the deviation to lower.	0 to 100 %	0
	Resonance suppression control D width	Sets the width of vibration to be suppressed.	30 to 120	30



The optimal value varies depending on the equipment or operating condition. Check it under the actual conditions of use.

2-3 Damping control

Even when the motor is installed in a machine with low rigidity, residual vibration during positioning can be suppressed to reduce the positioning time.

Related parameters

MEXE02 code	Name	Description	Setting range	Initial value
p11	Damping control frequency	Sets the frequency of vibration to be suppressed.	700 to 20,000 (1=0.01 Hz)	10,000
	Damping control gain	Sets the gain for damping control (vibration suppression control).	0 to 100 %	0



The optimal value varies depending on the equipment or operating condition. Check it under the actual conditions of use.

2-4 Electronic damper function

Whether to enable or disable the vibration suppression function (electronic damper function) set in the motor can be set.

Related parameter

MEXE02 code	Name	Description	Setting range	Initial value
p11	Electronic damper function	Sets the vibration suppression function.	0: Disable 1: Enable	1



Setting to "0: Disable" may be more effective for vibration suppression depending on a coupling and a load.

3 Cumulative load

The driver obtains the load factor in the motor operation pattern as an area, and it can notify as information if the integrated area (load) exceeds a certain value. This is a useful function that can be used as a guide to the motor life and the aged deterioration of equipment.

■ How to consider the cumulative load

As the operating time of the equipment passes, the friction force and load will increase by adhesion of rust or foreign particles, deterioration of grease, etc. Estimating this type of load increase (cumulative load) and setting to the information can prevent the equipment from stopping due to aging problems. Set a value having enough allowance because the load increases when starting or stopping.

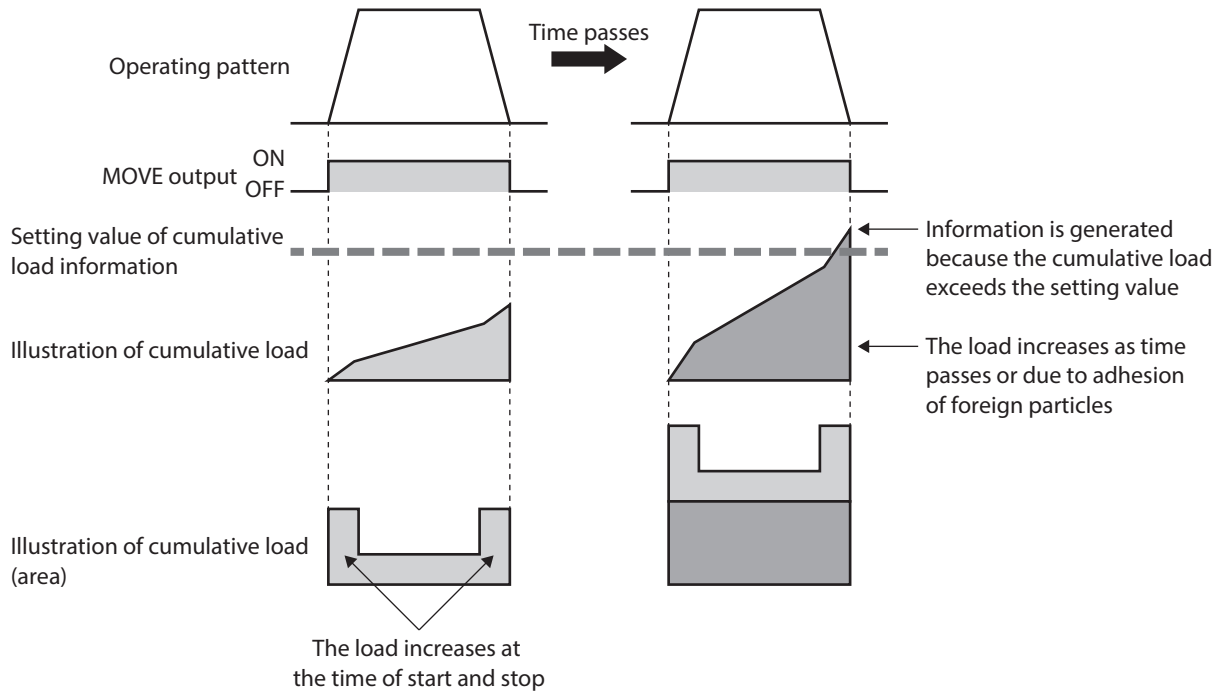

■ How to use

1. Open the status monitor window of the **MEXE02** software during operation to check the cumulative load in the normal operating pattern. Use this value having enough allowance and estimate the maximum value of the cumulative load.
2. Set the maximum value determined in the step 1 to the "Cumulative load information" parameter.
3. Equipment starts operating, and when the cumulative load of the motor reaches a value set in the step 2, information is generated. Perform maintenance on the equipment.

Note The information is cleared when the main power supply of the driver is turned off because the cumulative load is stored in RAM.

■ “Cumulative load value count divisor” parameter

The upper limit to count the cumulative load is 2,147,483,647.

If the operation time is long, the cumulative load may increase, making it difficult to manage, or the upper limit may be exceeded.

In this case, use the "Cumulative load value count divisor" parameter. The “Cumulative load value count divisor” parameter is a divisor used to divide the count value of the cumulative load. Dividing by the cumulative load value count divisor makes it easier to manage the count value.

- When the "Cumulative load value count divisor" parameter is set to "1"

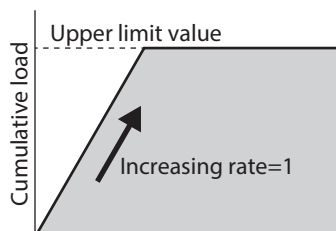

The upper limit value has been reached while operation is continued to perform, and the cumulative load cannot be counted

- When the "Cumulative load value count divisor" parameter is set to "5"

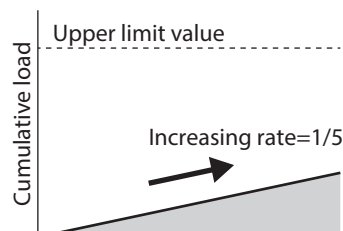

Increase slows down because the count value of the cumulative load is divided by "5"

■ “Cumulative load value auto clear” parameter

- If the "Cumulative load value auto clear" parameter is set to "1: Clear" (initial value: Clear), the cumulative load is cleared to 0 each time the MOVE output is turned ON. The cumulative load can be reset for each operation.
- If the "Cumulative load value auto clear" parameter is set to "0: Does not clear," the cumulative load is not reset even if the MOVE output is turned ON, and it is continued to integrate. The cumulative load can be monitored for a certain period of time or under a certain condition. When this parameter is set to "0: Does not clear," reset the cumulative load with the LAT-CLR input.

- When the "Cumulative load value auto clear" parameter is set to "1: Enable"

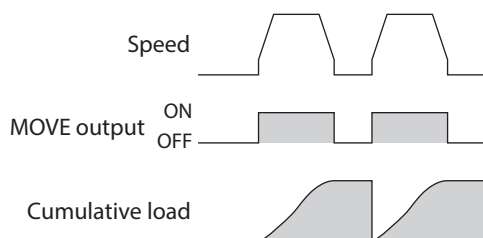

- When the "Cumulative load value auto clear" parameter is set to "0: Disable"

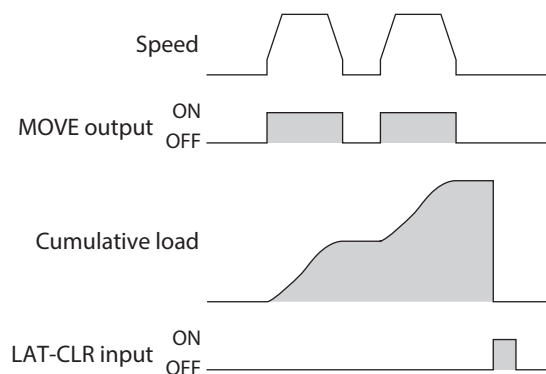

4 Load factor monitor

There are two methods to monitor the load factor of the motor, as shown below.

- Torque monitor: This indicates the output torque presently generated as a percentage of the rated torque.
- Load factor monitor: This indicates the motor output power presently generated as a percentage of the maximum output power in the continuous duty region.

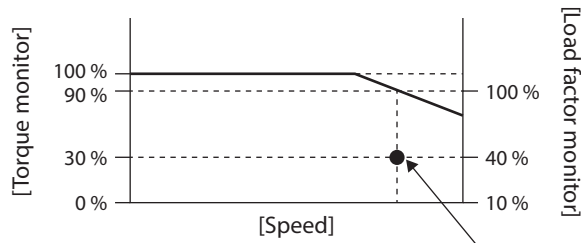

This is the load condition when the torque monitor shows 30 % and the load factor monitor shows 40 % at a certain speed.

5 Changing the function of the HOME PRESET switch

In the **AZX** Series, the function of the P-PRESET input is assigned to the HOME PRESET switch. Therefore, simply pressing the HOME PRESET switch can set the present position as the home.

However, after the home is set, the function of the HOME PRESET switch can be disabled so that the home will not be preset if the HOME PRESET switch is pressed accidentally.

As an alternative use, if the START input is assigned instead of the P-PRESET input, simply pressing the HOME PRESET switch can start operation.

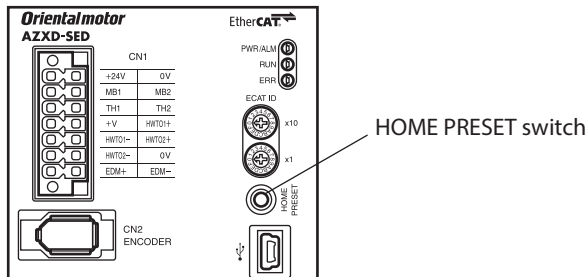

Related parameters

MEXE02 code	Name	Description	Setting range	Initial value
p9	Extended input (EXT-IN) function	Selects an input signal to be assigned to the HOME PRESET switch.	Input signals list ⇒ p.115	9: P-PRESET
	Extended input (EXT-IN) inverting mode	Changes the ON-OFF setting of the input signal to be assigned to the HOME PRESET switch.	0: Non invert 1: Invert	0
	Extended input (EXT-IN) interlock releasing time	Normally, the HOME PRESET switch is interlocked. Pressing and holding the switch for a certain amount of time will release the interlock and enable the assigned function. This parameter is used to set the amount of time that the switch must be pressed and held down in order to release the interlock.	0: Interlock disabled 1 to 50 (1=0.1 s)	10
	Extended input (EXT-IN) interlock releasing duration	Sets the amount of time that the state of releasing the interlock is maintained.	0 to 50 (1=0.1 s)	30
	Extended input (EXT-IN) ON monitor time	When a signal assigned to the switch is input, the LED is lit. This parameter is used to set the amount of time that the LED is lit.	0 to 50 (1=0.1 s)	10

7 Extended function

6 Simulating the driver operation

Using the driver simulation mode can simulate coordinates and I/O status without connecting a motor. If the motor is connected, the simulation closer to the actual operation can be made using the information of the ABZO sensor.

- Note**
- In the driver simulation mode, the motor does not operate regardless of whether a motor is connected or not.
 - In the driver simulation mode, the driver functions and I/O signals may differ from those in the normal state.
 - When simulating a motorized actuator, be sure to connect the actuator to the driver and cause the product-specific information to read. Failure to do so may result in injury or damage to equipment when performing operation actually.

memo Even if a motor and a driver are connected, the motor is in a non-excitation state during the simulation. When an electromagnetic brake motor is used, the output shaft is held by the electromagnetic brake.

Related parameter

MEXE02 code	Name	Description	Setting range	Initial value
p2	Driver simulation mode	Situation for coordinates or I/O can be simulated using a virtual motor without connecting a motor.	0: The motor is actually used 1: Virtual motor (when ABZO not connected=no ABZO information) 2: Virtual motor (when ABZO not connected=1,800 rev wrap enable) 3: Virtual motor (when ABZO not connected=900 rev wrap enable)	0

■ Use this function for the following.

- To check the driver command information
- To check the wiring
- To check the operation data and parameters
- To check the I/O signal status.
- To verify when an error occurs in the system

6-1 Preparation and operating procedure for driver simulation mode

■ Preparation

- When a motor is not connected

Note When simulating a motorized actuator, be sure to connect the actuator to the driver.

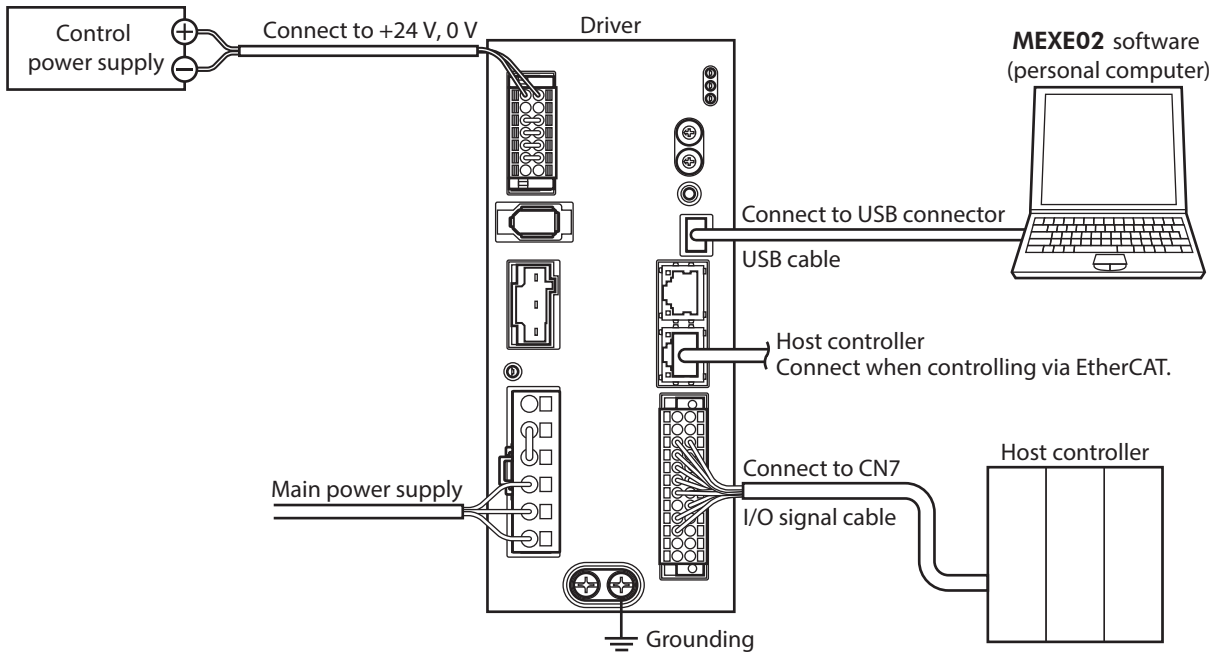

- When connecting a motor

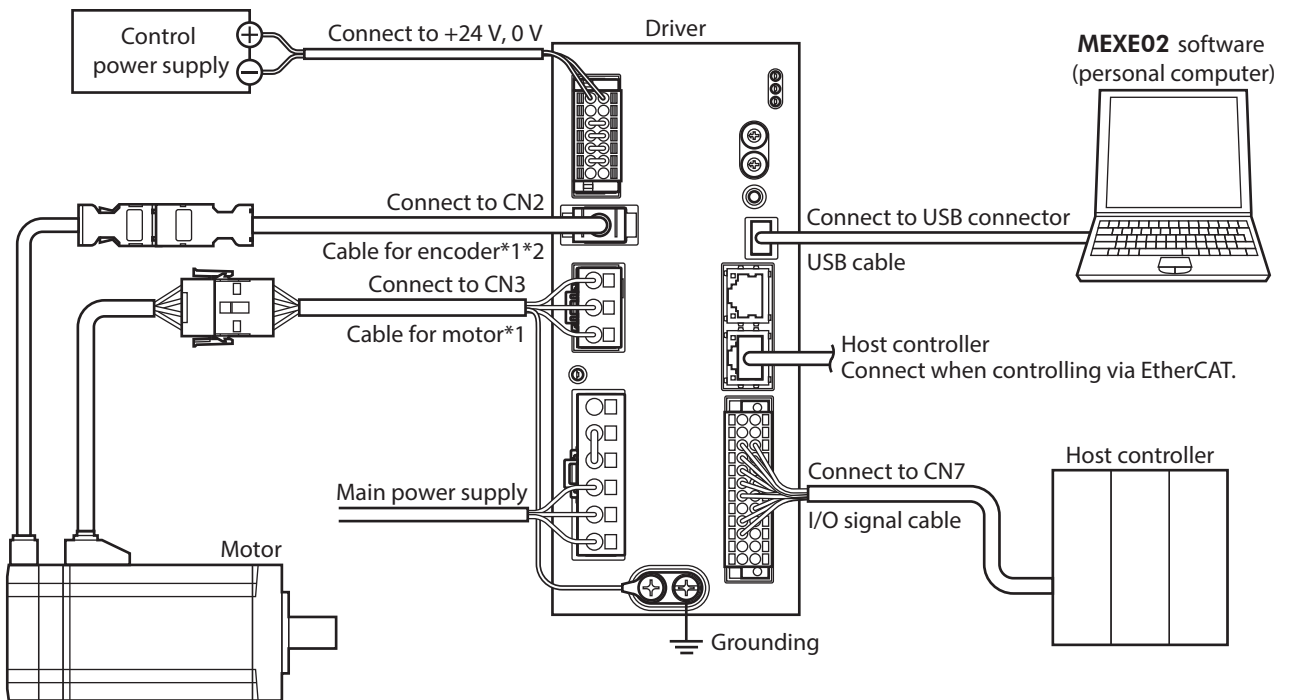

*1 Purchase is required separately.

*2 Use the cable for encoder when the length of the encoder cable of motor is not enough.

■ Operating procedure

This section explains how to simulate the driver operation without connecting a motor using the **MEXE02** software.

1. Turn on the control power supply and the main power supply of the driver.
2. Set the "Driver simulation mode" parameter of the **MEXE02** software to "Virtual motor."
3. Click the [Data writing] icon to write the data to the driver.
4. When writing is completed, turn off the control and main power supplies of the driver and on again.
5. Check if the "Driver simulation mode" parameter is updated.
Check the PWR/ALM LED of the driver repeats the following blinking.
 - Green light → Red light → Green and red colors are simultaneously lit (red and green colors may overlap and it may be visible to orange.) → No light
6. Execute positioning operation or other operation with "Remote operation" of the **MEXE02** software.
Even if a motor is not connected, the command position or the feedback position will increase or decrease.
Situation for coordinates or I/O can also be checked using the I/O monitor, the status monitor, or the waveform monitor.
7. End the driver simulation mode.
 - 1) Set the "Driver simulation mode" parameter to "0: The motor is actually used."
 - 2) Click the [Data writing] icon to write the data to the driver.
 - 3) Turn off the control power supply and the main power supply of the driver.

6-2 Coordinates

■ Origin

In the driver simulation mode, the position when the control power supply is turned on is set as the home regardless of whether a motor is connected or not. The home can be set again by return-to-home operation or position preset. However, the home information of the ABZO sensor cannot be rewritten.

■ Coordinate generation (when a motor is not connected)

The method to generate coordinates varies depending on the setting of the "Initial coordinate generation & wrap coordinate setting" parameter.

MEXE02 code	Name	Setting	Coordinate generation method
p3	Initial coordinate generation & wrap coordinate setting	0: Prioritize ABZO setting	Depends on the "Driver simulation mode" parameter.
		1: Manual setting	Uses the user parameter to generate coordinates.

The method to generate coordinates is as follows when the "Initial coordinate generation & wrap coordinate setting" parameter is set to "0: Prioritize ABZO setting."

MEXE02 code	Name	Setting	Coordinate generation method
p2	Driver simulation mode	1: Virtual motor (when ABZO not connected=no ABZO information)	Uses the user parameter to generate coordinates.
		2: Virtual motor (when ABZO not connected=1,800 rev wrap enable)	The "Initial coordinate generation & wrap coordinate" parameter is set as follows. <ul style="list-style-type: none"> Initial coordinate generation & wrap setting range: 1,800 Initial coordinate generation & wrap range offset ratio: 50 Initial coordinate generation & wrap range offset value: 0 Wrap (RND) setting: Enable The number of the RND-ZERO output in wrap range: 1,800
		3: Virtual motor (when ABZO not connected=900 rev wrap enable)	The "Initial coordinate generation & wrap coordinate" parameter is set as follows. <ul style="list-style-type: none"> Initial coordinate generation & wrap setting range: 900 Initial coordinate generation & wrap range offset ratio: 50 Initial coordinate generation & wrap range offset value: 0 Wrap (RND) setting: Enable The number of the RND-ZERO output in wrap range: 900

Coordinate generation (when a motor is connected)

The method to generate coordinates varies depending on the settings of the "Mechanism settings" parameter and the "Initial coordinate generation & wrap coordinate setting" parameter.

MEXE02 code	Name	Setting	Coordinate generation method
p3	<ul style="list-style-type: none"> Mechanism settings Initial coordinate generation & wrap coordinate setting 	0: Prioritize ABZO setting	Uses the setting of the ABZO sensor.
		1: Manual setting	Uses the user parameter to generate coordinates.

6-3 Monitor

This section explains contents that can be checked with the status monitor of the **MEXE02** software during simulation.

The following describes the displayed items that are different from those at the normal time.

Item	Description
<ul style="list-style-type: none"> Feedback position 32-bit counter Feedback position Feedback speed 	Indicates the coordinate information detected by the ABZO sensor. The coordinate information follows the command regardless of whether a motor is connected or not.
<ul style="list-style-type: none"> Cumulative load Torque Position deviation Motor load factor 	Indicates the value calculated from the driver command information and the motor detection information. The value is undefined regardless of whether a motor is connected or not.
<ul style="list-style-type: none"> Motor temperature 	Indicates the temperature information detected by the ABZO sensor. The value is undefined when a motor is not connected.
<ul style="list-style-type: none"> Odometer Tripmeter 	Indicates the information of the ABZO sensor. The value is not updated during simulation regardless of whether a motor is connected or not.

6-4 Operation

This section explains the operation of the driver simulation mode.

■ Cyclic synchronous position mode, Profile position mode, Cyclic synchronous speed mode, Profile velocity mode

Data input from the MainDevice via EtherCAT is used. (Details of drive profile ⇨ p.71)

■ Homing mode (Return-to-home)

When the Homing mode is started via EtherCAT, the simulation of return-to-home operation is started. However, since a motor does not operate in the driver simulation mode, an external sensor cannot be detected. Therefore, to simulate return-to-home operation, it is necessary to turn the sensor input ON intentionally.



The home of the ABZO sensor cannot be rewritten even if operation is completed.

6-5 I/O signals

This section explains the I/O signals whose specifications and operations are different in the driver simulation mode than in the normal time.



The following are the differences between simulation and normal time. Therefore, the ON-OFF status of I/O signals may differ from the normal time.

- Parameters related to I/O signals are disabled even if they are set.
- The motor is in a non-excitation state and the electromagnetic brake is in a state of holding the motor shaft regardless of the status of the I/O signals.

Example: When the FREE input is turned ON, the output signals indicate a non-excitation state for the motor (the SON-MON output is OFF) and a release state for the electromagnetic brake (the MBC output is OFF), but the motor remains in a non-excitation state and the electromagnetic brake remains in a state of holding the motor shaft.

■ Output signals

Signal name	Driver simulation mode	Normal time
ABSPEN	Always ON	Output when coordinates are set.
PRST-STLD	Always OFF	Output when the mechanical home is set.
ORGN-STLD	Always OFF	Output when the mechanical home based on the product is set at the time of factory shipment.

6-6 Alarms

In the driver simulation mode, an alarm of Sensor error at power-on is not generated.

7 Using general signals

The R0 to R15 inputs are general-purpose signals. Using the R0 to R15 inputs, I/O signals of the external device can be controlled by the host controller via the driver. Direct I/O of the driver can be used as an I/O module.

■ Example of use for general signals

● When signals are output from the host controller to the external device

Assign the R0 input to R-IN0 and the R0_R output to DOUT0.

DOUT0 is turned ON when R-IN0 is set to 1 by the host controller, and DOUT0 is turned OFF when R-IN0 is set to 0.

● When outputs of the external device are input to the host controller

Assign the R1 input to DIN1 and the R1_R output to R-OUT1.

R-OUT1 is set to 1 when DIN1 is turned ON by the external device, and R-OUT1 is set to 0 when DIN1 is turned OFF. ON-OFF of DIN1 can be set using the "DIN1 inverting mode" parameter.

● Related parameters

MEXE02 code	Name	Description	Setting range	Initial value
p6	DIN0 input function	Selects an input signal to be assigned to DIN.	Input signals list ⇒ p.115	30: HOMES
	DIN1 input function			1: FREE
	DIN2 input function			12: ETO-CLR
	DIN3 input function			104: EXT1
	DIN4 input function			28: FW-LS
	DIN5 input function			29: RV-LS
	DIN0 inverting mode	Changes the ON-OFF setting of DIN.	0: Non invert 1: Invert	0
	DIN1 inverting mode			0
	DIN2 inverting mode			0
	DIN3 inverting mode			0
	DIN4 inverting mode			0
DIN5 inverting mode	0			
p7	DOUT0 (Normal) output function	Selects an output signal to be assigned to DOUT.	Output signals list ⇒ p.116	144: HOME-END
	DOUT1 (Normal) output function			137: ETO-MON
	DOUT2 (Normal) output function			0: No function
	DOUT3 (Normal) output function			142: SON-MON
	DOUT4 (Normal) output function			134: MOVE
	DOUT5 (Normal) output function			130: ALM-B
	DOUT0 inverting mode	Changes the ON-OFF setting of DOUT.	0: Non invert 1: Invert	0
	DOUT1 inverting mode			0
	DOUT2 inverting mode			0
	DOUT3 inverting mode			0
	DOUT4 inverting mode			0
DOUT5 inverting mode	0			
p8	R-IN0 input function	Selects an input signal to be assigned to R-IN.	Input signals list ⇒ p.115	0: No function
	R-IN1 input function			0: No function
	R-IN2 input function			0: No function
	R-IN3 input function			0: No function
	R-IN4 input function			0: No function
	R-IN5 input function			0: No function
	R-IN6 input function			0: No function
	R-IN7 input function			0: No function

MEXE02 code	Name	Description	Setting range	Initial value
p8	R-IN8 input function	Selects an input signal to be assigned to R-IN.	Input signals list ⇒ p.115	0: No function
	R-IN9 input function			0: No function
	R-IN10 input function			0: No function
	R-IN11 input function			0: No function
	R-IN12 input function			0: No function
	R-IN13 input function			0: No function
	R-IN14 input function			0: No function
	R-IN15 input function			0: No function
	R-OUT0 output function	Selects an output signal to be assigned to R-OUT.	Output signals list ⇒ p.116	28: FW-LS_R
	R-OUT1 output function			29: RV-LS_R
	R-OUT2 output function			155: ZSG
	R-OUT3 output function			0: No function
	R-OUT4 output function			144: HOME-END
	R-OUT5 output function			204: DCMD-RDY
	R-OUT6 output function			135: INFO
	R-OUT7 output function			129: ALM-A
	R-OUT8 output function			136: SYS-BSY
	R-OUT9 output function			160: AREA0
	R-OUT10 output function			161: AREA1
	R-OUT11 output function			162: AREA2
	R-OUT12 output function			0: No function
	R-OUT13 output function			134: MOVE
	R-OUT14 output function			138: IN-POS
	R-OUT15 output function			140: TLC

- Unauthorized reproduction or copying of all or part of this manual is prohibited.
If a new copy is required to replace an original manual that has been damaged or lost, please contact your nearest Oriental Motor branch or sales office.
- Oriental Motor shall not be liable whatsoever for any problems relating to industrial property rights arising from use of any information, circuit, equipment or device provided or referenced in this manual.
- Characteristics, specifications and dimensions are subject to change without notice.
- While we make every effort to offer accurate information in the manual, we welcome your input. Should you find unclear descriptions, errors or omissions, please contact the nearest office.
- **Oriental motor** and ABZO sensor are registered trademarks or trademarks of Oriental Motor Co., Ltd., in Japan and other countries.
EtherCAT® is a registered trademark and patented technology, licensed by Beckhoff Automation GmbH, Germany.
Other product names and company names mentioned in this manual may be registered trademarks or trademarks of their respective companies and are hereby acknowledged. The third-party products mentioned in this manual are recommended products, and references to their names shall not be construed as any form of performance guarantee. Oriental Motor is not liable whatsoever for the performance of these third-party products.

© Copyright ORIENTAL MOTOR CO., LTD. 2023

Published in August 2024

- Please contact your nearest Oriental Motor office for further information.

ORIENTAL MOTOR U.S.A. CORP.
Technical Support Tel:800-468-3982
8:30am EST to 5:00pm PST (M-F)

ORIENTAL MOTOR (EUROPA) GmbH
Schiesstraße 44, 40549 Düsseldorf, Germany
Technical Support Tel:00 800/22 55 66 22

ORIENTAL MOTOR (UK) LTD.
Unit 5 Faraday Office Park, Rankine Road,
Basingstoke, Hampshire RG24 8QB UK
Tel:+44-1256347090

ORIENTAL MOTOR (FRANCE) SARL
Tel:+33-1 47 86 97 50

ORIENTAL MOTOR ITALIA s.r.l.
Tel:+39-02-93906347

ORIENTAL MOTOR ASIA PACIFIC PTE. LTD.
Singapore
Tel:1800-842-0280

ORIENTAL MOTOR (MALAYSIA) SDN. BHD.
Tel:1800-806-161

ORIENTAL MOTOR (THAILAND) CO., LTD.
Tel:1800-888-881

ORIENTAL MOTOR (INDIA) PVT. LTD.
Tel:1800-120-1995 (For English)
1800-121-4149 (For Hindi)

TAIWAN ORIENTAL MOTOR CO., LTD.
Tel:0800-060708

SHANGHAI ORIENTAL MOTOR CO., LTD.
Tel:400-820-6516

INA ORIENTAL MOTOR CO., LTD.
Korea
Tel:080-777-2042

ORIENTAL MOTOR CO., LTD.
4-8-1 Higashiueno, Taito-ku, Tokyo
110-8536 Japan
Tel:+81-3-6744-0361
www.orientalmotor.co.jp/ja