

Orientalmotor

Brushless Motors
BMU Series
NEW Connector Type

Easy speed control, easier to use.

New connector type with smart wiring.



The new connector type in the compact, high-efficiency **BMU** series, directly connects the motor and driver together.

Smart wiring and watertight and dust-resistant performance (degree of protection IP66) have been achieved.



Connector Type Features

A connector has been newly developed for small motors. Direct connection between the motor and driver is now possible.

Together with the improved motor structure, watertight and dust-resistant performance has also been increased, achieving a IP66 level of protection*. *Motor only

New Connector

The gasket and O-ring are built-in, improving water ingress protection. A lock lever system which does not require screw fitting is employed, making connection easy.

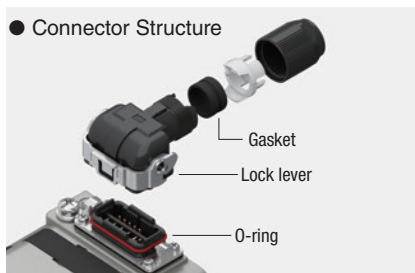

● Installation Method



Directly Connect the Motor and Driver

Can be connected up to 10 m max. with no relay. Cable relay processing is unnecessary. The power line, signal line, and ground wire are all contained in one cable, reducing wiring work.

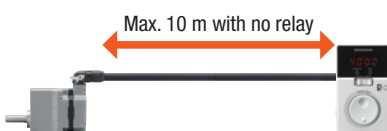

Select the Cable Pull-out Direction

Three cable pull-out direction options are available to suit the equipment. (The only cable pull-out direction of the round shaft type is the rear of the motor.)

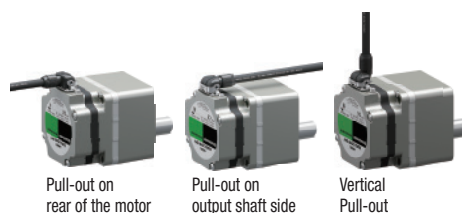

Stainless Steel Shaft Comes Standard

EURONORM X 10 CrNiS 18 9, which has excellent anti-rust and anti-corrosion properties, is used for the shaft. Stainless steel is also used for the parallel key and installation screws.





NexBL is the new brushless motor from Oriental Motor. The entire motor structure has been redesigned in an effort to maximize the required performance. Unprecedented compact size, high power, and high efficiency.

Brushless Motor Features

Brushless motors don't have brushes, which are the weak point of DC motors, so they create little noise and are maintenance-free.

Since they use a permanent magnet, they are compact, high-power, and high-efficiency.

Broad Speed Control Range

Brushless motors have a broader range of speed control than AC speed control motors and inverters. They are suitable for applications that require constant torque from low speed to high speed.

Product Group	Speed Control Range*	Speed Ratio
BMU Series Brushless Motors	80 ~ 4000 r/min	1:50
Inverter-Controlled Three-Phase Induction Motor	200 ~ 2400 r/min	1:12
AC Speed Control Motors	50 Hz : 90 ~ 1400 r/min	1:15
	60 Hz : 90 ~ 1600 r/min	1:17

*The speed control range differs depending on the model.

Slim, Lightweight, High-Power

Brushless motors contain a permanent magnet in the rotor, so they are slim, lightweight, and provide high-power. This contributes to equipment downsizing.

[Comparative example with 200 W output]

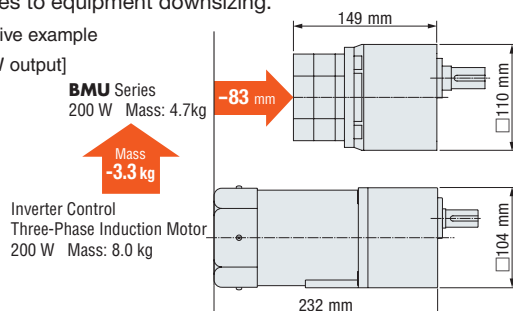

Stable Speed Control is Possible

Brushless motors constantly monitor feedback signals from the motor, compared with the setting speed, and adjust the applied voltage. This means that the motor rotates at a stable speed from low speed to high speed, even if the load changes.

● Comparison of Speed Variation at 80% Load Factor (Reference value)

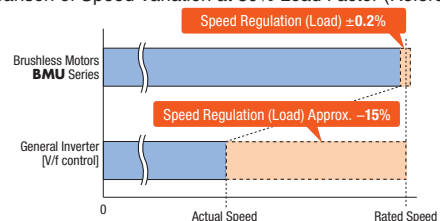

Contributes to Equipment Energy Savings

Brushless motors contain a permanent magnet in the rotor, inhibiting secondary rotor loss and greatly reducing power consumption. This helps the equipment to save energy.

[Comparative example with 200 W output]

● Rated output power at 50 Hz (Representative value)

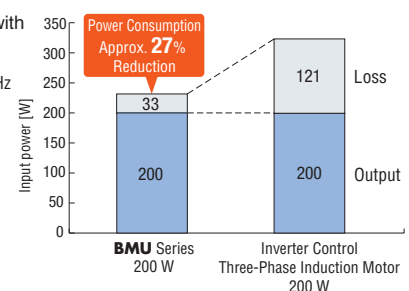

Many convenient functions that a speed control motor requires.

Here are the main points

Speed Indicator

Displays the motor speed in 1 r/min units. By calculating the conveyor gear ratio and setting gear ratio parameters, the conveyor transportation speed can be displayed in m/s. The conveyor transportation speed can be confirmed directly.



Load Factor Indicator

With the rated torque of the motor at 100%, the load factor can be expressed as a percentage (40~200%). The load condition during start-up, as well as the load condition due to the age deterioration of the equipment, can be confirmed.



Indication at a load factor of 50%

Protective Functions

Contains various protective functions, such as an overload protection function and overvoltage protection function. When a protective function activates, the alarm code is displayed on the indicator and an alarm signal is displayed.



4-Speed Operation

4-speed operation is possible by setting the data to operating data slots No.0, No.1, No.2 or No.3, and switching the input of the M0 and M1 terminals.

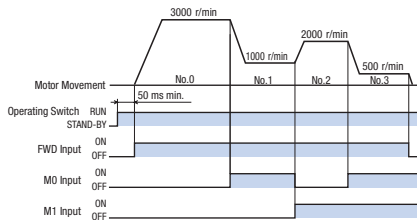

- When operating in 4-speed settings, the rotation direction of the motor cannot be changed by external input signals.

Set the Acceleration/Deceleration Time

Acceleration time and deceleration time settings can be adjusted with the acceleration/deceleration time potentiometer, as well as digitally set.

- Setting Range:
0.0~15.0 sec (initial value: 0.5 sec)

In the case for digital setting, acceleration and deceleration time can be independently set, so times can be freely set by fine-tuning shock alleviation when the load has started and stopped, together with cycle time.

Other Functions

- Lock Dial Operations
Unintended speed changes and data editing/deletion through dial operations can be prevented.
- Front Panel Operation Can Be Disabled
When the motor is operated in external signal mode, the front panel operation switches can be disabled.
- Output Shaft Holding when Stopped
The load can be electrically held when the motor is at standstill. (Holding force up to 50% of rated torque)

Note

If the power supply to the driver is turned OFF, the holding force dissipates. This cannot be used to prevent a fall during a power outage.

Various functions can be set by opening the front panel of the driver.

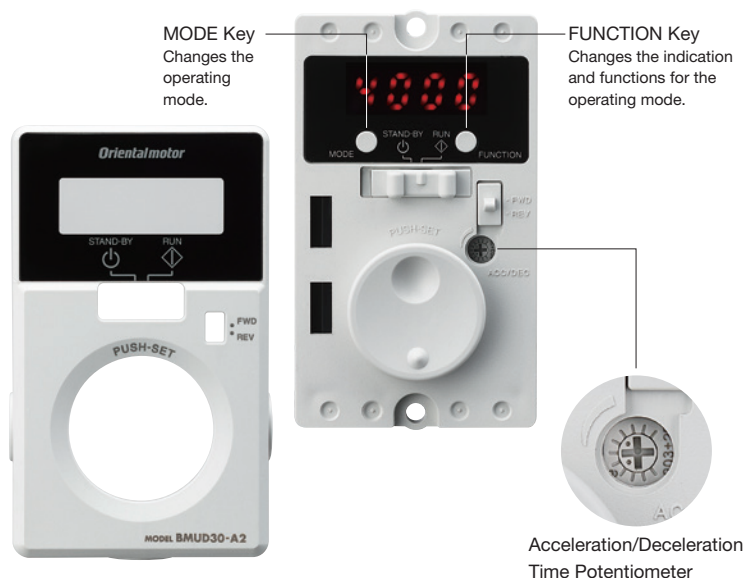

<Typical Functions that can be Set while the Front Panel is Opened>

- Motor start/stop*
 - Adjusting the operating speed*
 - Setting the operating speed*
 - Switching the rotation direction*
 - Changing the indication
 - Indicating the operating speed when the speed reduction/speed increasing ratio is set
 - Setting the acceleration/deceleration time
 - Dial operation lock
 - Speed setting for the 4-speed operation
 - Speed limits setting
 - Validating the external operating signals
 - External input/output signal allocation
 - Setting the overload alarm detection time
Except when shaft is locked
 - Load holding function for output shaft
- *Setting is possible even if the front panel is attached.

Easy Operation

Turn & Press

Turn the dial and set to the desired speed. The speed can be set just by pressing the dial.



Start/Stop

Can be easily driven and stopped with the operating switch on the front. There is no need to provide a switch externally.



Switching the Rotation Direction

The motor's rotation direction can be switched with the rotation direction switch. It can even be changed during operation.



Easy Wiring

Direct Connection to the Motor

Easy connection between the motor and connection cable by inserting the connector and lowering the lock lever. Newly designed for small motors.



Easy Connection on the Driver Side too

The driver connector is a small format connector that easily passes through flexible conduits and cable glands.

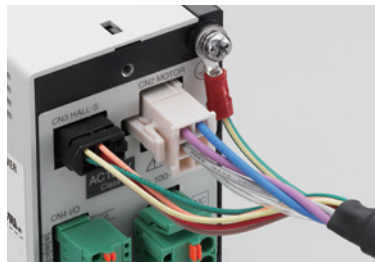

The Power and I/O Connectors Feature a Screwless Connector

Connection to the power connector and I/O connector do not require any special crimp tools or soldering. Just insert the lead wire.



Easy Assembly

The Combination Type has a New Gearhead

The gearhead has improved gear-motor coupling accuracy due to the use of boss and installation surface cutting. It also produces less noise than

conventional products. The combination type comes with the motor and gearhead already assembled, making assembly in the equipment easy.

Motor



Gearhead



+



Combination Type

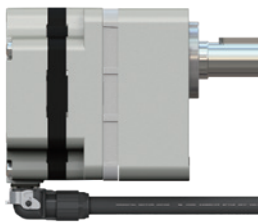

An IP66-Compatible High-Efficiency Brushless Motor.

The New Brushless Motor NexBL

Designed to be Compact, High Power and High Efficiency

Optimal magnetic design and high-performance materials allow for a stator lamination thickness of only 11.2mm in the NexBL. This thinness achieves a highly efficient power unit that can output 120 W. Compared with a conventional brushless motor of the same output power, the stator plate thickness is reduced by half (for motors with a frame size of 90 mm). Moreover, by using high-performance materials while reducing the amount of material used, costs have been reduced significantly.

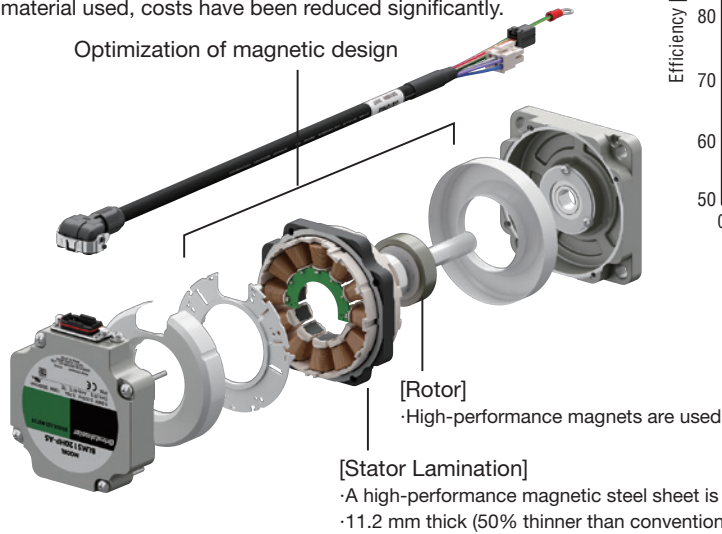





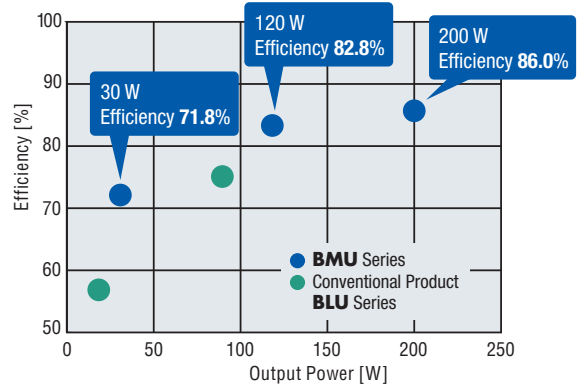

Greatly Increased Efficiency

The **BMU** series has up to 15% points better efficiency in motor/driver units compared to conventional products*.

*Comparison between the **BMU** series 30 W and the **BLU** series 20 W.



Product Lineup

Motor	Output Power	Frame Size	Gearhead Gear Ratio (Combination type)	Driver	Power Supply Voltage	Connection Cable			
 Combination Type	30 W	Combination Type 60 mm Round Shaft Type	5, 10, 15, 20, 30, 50, 100, 200		Single-phase 100-120 VAC Single-phase 200-240 VAC Three-phase 200-240 VAC	BLE2 Series 0.5~20 m Pull-out on output shaft side 			
	60 W	Combination Type 80 mm Round Shaft Type 60 mm	5, 10, 15, 20, 30, 50, 100, 200						
 Round Shaft Type*	120 W	Combination Type 90 mm Round Shaft Type	5, 10, 15, 20, 30, 50, 100, 200					Single-phase 200-240 VAC Three-phase 200-240 VAC	Pull-out on rear of the motor 
	200 W	Combination Type 110 mm Round Shaft Type 90 mm	5, 10, 15, 20, 30, 50, 100, 200						
	300 W	Combination Type 110 mm Round Shaft Type 90 mm	5, 10, 15, 20, 30, 50, 100						

*Only the rear side pull-out connection cable can be combined with the round shaft type. The round shaft type also includes a shaft flat type.

System Configuration

Motors, drivers, and connection cables are supplied separately.

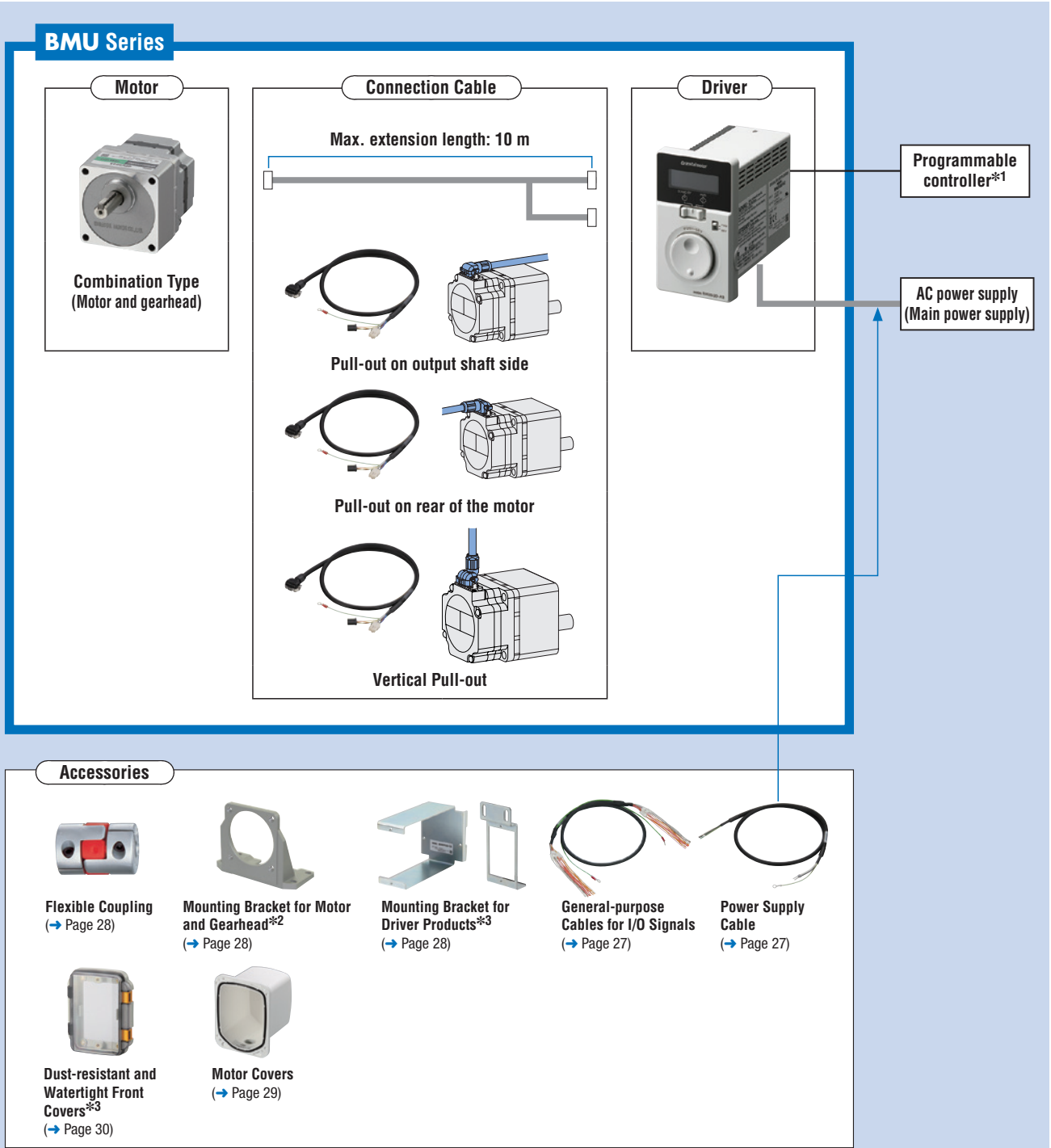

*1 Not supplied.

*2 Refer to page 28 for motor and gearhead installation directions.

*3 A mounting bracket for circuit products and dust-resistant and watertight front cover cannot be used in combination.

Example of System Configuration

BMU Series				+	Accessories		
Motor	Gearhead	Driver	Connection Cable (1 m)		Mounting Bracket for Motor and Gearhead	Flexible Coupling	Mounting Bracket for Circuit Products
BLM230-GFV2	GFV2G10	BMUD30-A2	CC01BL2		SOL2M4F	MCL301010	MAFP05V

● The system configuration shown above is an example. Other combinations are also available.

Product Number

Motor

BLM 4 60 S H P - GFV □

① ② ③ ④ ⑤ ⑥ ⑦ ⑧

Gearhead

GFV 2 G 50 S

① ② ③ ④

Driver

BMUD 60 - A 2

① ② ③ ④

Connection Cable

CC 010 KH BL F

① ② ③ ④ ⑤

①	Motor Type	BLM: Brushless motor
②	Frame Size	2: 60 mm 4: 80 mm 5: 90 mm 6: 104 mm 7: 110 mm
③	Output Power	30: 30 W 60: 60 W 120: 120 W 200: 200 W 300: 300 W
④	Identification Number	S
⑤	Motor Connection Method	H: Connector type
⑥	Motor Degree of Protection	P: IP66 specification
⑦	Motor Shaft Configuration	GFV, GFV2: GFV Pinion A, A2: Round shaft type AC: Round shaft type (shaft flat)
⑧	Output Shaft Material	S: Stainless Steel

①	Motor Shaft type	GFV, GFV Pinion
②	Frame Size	2: 60 mm 4: 80 mm 5: 90 mm 6: 104 mm
③	Gear Ratio	Number : Gear ratio
④	Output Shaft Material	Blank B: Iron S: Stainless Steel

①	Driver Type	BMUD: BMU Series driver
②	Output	30: 30 W 60: 60 W 120: 120 W 200: 200 W 300: 300 W
③	Power Supply Voltage	A: Single-phase 100-120 VAC C: Single-phase, three-phase 200-240 VAC*
④	Reference number	

①	Cable type	CC: Connection cable
②	Length	005: 0.5 m 010: 1 m 015: 1.5 m 020: 2 m 025: 2.5 m 030: 3 m 040: 4 m 050: 5 m 070: 7 m 100: 10 m
③	Motor connection method	KH: Metal connector type
④	Applicable model	BL: Brushless motor
⑤	Cable pull-out direction	F: Output shaft direction B: Rear side direction V: Vertical direction

*WARNING: Connecting the **BLE2** to three-phase 400 VAC will damage the product.

Product Line

Please purchase a motor, a driver, and a connection cable.

● Motor

◇ Pinion Shaft type



Output Power	Product Name
30 W	BLM230HP-GFV
60 W	BLM460SHP-GFV
120 W	BLM5120HP-GFV
200 W	BLM6200SHP-GFV
300 W	BLM6300SHP-GFV

◇ Round Shaft type



Output Power	Product Name
30 W	BLM230HP-AS
60 W	BLM260HP-AS
120 W	BLM5120HP-AS
200 W	BLM5200HP-AS
300 W	BLM5300HP-AS

● Gearheads

◇ Parallel Shaft Gearheads



Output Power	Product Name	Gear Ratio
30 W	GFV2G□S	5, 10, 15, 20
		30, 50, 100
		200
60 W	GFV4G□S	5, 10, 15, 20
		30, 50, 100
		200
120 W	GFV5G□S	5, 10, 15, 20
		30, 50, 100
		200
200 W 300 W	GFV6G□S	5, 10, 15, 20
		30, 50
		100, 200

● Drivers



Output Power	Power Supply Voltage	Product Name
30 W	Single-Phase 100-120 VAC	BMUD30-A2
	Single-Phase, Three-Phase 200-240 VAC	BMUD30-C2
60 W	Single-Phase 100-120 VAC	BMUD60-A2
	Single-Phase, Three-Phase 200-240 VAC	BMUD60-C2
120 W	Single-Phase 100-120 VAC	BMUD120-A2
	Single-Phase, Three-Phase 200-240 VAC	BMUD120-C2
200 W	Single-Phase 100-120 VAC	BMUD200-A
	Single-Phase, Three-Phase 200-240 VAC	BMUD200-C
300 W	Single-Phase, Three-Phase 200-240 VAC	BMUD300-C

● A number indicating the gear ratio is specified where the box □ is located in the product name.

Specifications

30 W



Product Name	Motor / Gearhead	Round Shaft Type	BLM230HP-GFV / GFV2G□S	
			BLM230HP-AS	
Driver		BMUD30-A2	BMUD30-C2	
Rated Output Power (Continuous)	W	30		
Power Supply Input	Rated Voltage	VAC	Single-Phase 100-120	Single-Phase 200-240 / Three-Phase 200-240
	Permissible Voltage Range		-15 - +10%	
	Frequency	Hz	50 / 60	
	Permissible Frequency Range		±5%	
	Rated Input Current	A	1.2	Single-Phase: 0.7 / Three-Phase: 0.38
	Maximum Input Current	A	2.0	Single-Phase: 1.2 / Three-Phase: 0.75
Rated Speed	r/min	3000		
Speed Control Range		80 - 4000 r/min (speed ratio 1:50)		
Speed Regulation	Load	±0.2% or less: Conditions 0 - rated torque, rated speed, rated voltage, normal ambient temperature		
	Voltage	±0.2% or less: Conditions Rated voltage -15 - 10%, rated speed, no load, normal ambient temperature		
	Temperature	±0.2% or less: Conditions Operating ambient temperature 0 - +40°C, rated speed, no load, rated voltage		

60 W



Product Name	Motor / Gearhead	Round Shaft Type	BLM460SHP-GFV / GFV4G□S	
			BLM260HP-AS	
Driver		BMUD60-A2	BMUD60-C2	
Rated Output Power (Continuous)	W	60		
Power Supply Input	Rated Voltage	VAC	Single-Phase 100-120	Single-Phase 200-240 / Three-Phase 200-240
	Permissible Voltage Range		-15 - +10%	
	Frequency	Hz	50 / 60	
	Permissible Frequency Range		±5%	
	Rated Input Current	A	1.7	Single-Phase: 1.0 / Three-Phase: 0.52
	Maximum Input Current	A	3.3	Single-Phase: 1.9 / Three-Phase: 1.1
Rated Speed	r/min	3000		
Speed Control Range		80 - 4000 r/min (speed ratio 1:50)		
Speed Regulation	Load	±0.2% or less: Conditions 0 - rated torque, rated speed, rated voltage, normal ambient temperature		
	Voltage	±0.2% or less: Conditions Rated voltage -15 - 10%, rated speed, no load, normal ambient temperature		
	Temperature	±0.2% or less: Conditions Operating ambient temperature 0 - +40°C, rated speed, no load, rated voltage		

120 W



Product Name	Motor / Gearhead	Round Shaft Type	BLM5120HP-GFV / GFV5G□S	
			BLM5120HP-AS	
Driver		BMUD120-A2	BMUD120-C2	
Rated Output Power (Continuous)	W	120		
Power Supply Input	Rated Voltage	VAC	Single-Phase 100-120	Single-Phase 200-240 / Three-Phase 200-240
	Permissible Voltage Range		-15 - +10%	
	Frequency	Hz	50 / 60	
	Permissible Frequency Range		±5%	
	Rated Input Current	A	3.3	Single-Phase: 2.0 / Three-Phase: 1.1
	Maximum Input Current	A	6.8	Single-Phase: 4.1 / Three-Phase: 2.0
Rated Speed	r/min	3000		
Speed Control Range		80 - 4000 r/min (speed ratio 1:50)		
Speed Regulation	Load	±0.2% or less: Conditions 0 - rated torque, rated speed, rated voltage, normal ambient temperature		
	Voltage	±0.2% or less: Conditions Rated voltage -15 - 10%, rated speed, no load, normal ambient temperature		
	Temperature	±0.2% or less: Conditions Operating ambient temperature 0 - +40°C, rated speed, no load, rated voltage		

● For detailed information about standards, please see the Oriental Motor website.

● The values correspond to each specification and characteristics of a stand-alone motor. The speed - torque characteristics show the values when rated voltage is applied.

● A number indicating the gear ratio is specified where the box □ is located in the product name.

● 200 W



Product Name		Motor / Gearhead	Round Shaft Type	BLM6200SHP-GFV / GFV6G□S	
		Driver		BLM5200HP-AS	
				BMUD200-A	BMUD200-C
Rated Output Power (Continuous)		W		200	
Power Supply Input	Rated Voltage	VAC		Single-Phase 100-120	Single-Phase 200-240 / Three-Phase 200-240
	Permissible Voltage Range			-15 - +10%	
	Frequency	Hz		50 / 60	
	Permissible Frequency Range			±5%	
	Rated Input Current	A		4.6	Single-Phase: 2.7 / Three-Phase: 1.5
	Maximum Input Current	A		9.3	Single-Phase: 4.9 / Three-Phase: 3.4
Rated Speed		r/min		3000	
Speed Control Range				80 - 4000 r/min (speed ratio 1:50)	
Speed Regulation	Load			±0.2% or less: Conditions 0 - rated torque, rated speed, rated voltage, normal ambient temperature	
	Voltage			±0.2% or less: Conditions Rated voltage -15 - 10%, rated speed, no load, normal ambient temperature	
	Temperature			±0.2% or less: Conditions Operating ambient temperature 0 - +40°C, rated speed, no load, rated voltage	

● 300 W



Product Name		Motor / Gearhead	Round Shaft Type	BLM6300SHP-GFV / GFV6G□S	
		Driver		BLM5300HP-AS	
				BMUD300-C	
Rated Output Power (Continuous)		W		300	
Power Supply Input	Rated Voltage	VAC		Single-Phase 200-240 / Three-Phase 200-240	
	Permissible Voltage Range			-15 - +10%	
	Frequency	Hz		50 / 60	
	Permissible Frequency Range			±5%	
	Rated Input Current	A		Single-Phase: 3.4 / Three-Phase: 2.1	
	Maximum Input Current	A		Single-Phase: 7.8 / Three-Phase: 4.7	
Rated Speed		r/min		3000	
Speed Control Range				80 - 4000 r/min (speed ratio 1:50)	
Speed Regulation	Load			±0.2% or less: Conditions 0 - rated torque, rated speed, rated voltage, normal ambient temperature	
	Voltage			±0.2% or less: Conditions Rated voltage -15 - 10%, rated speed, no load, normal ambient temperature	
	Temperature			±0.2% or less: Conditions Operating ambient temperature 0 - +40°C, rated speed, no load, rated voltage	

● For detailed information about standards, please see the Oriental Motor website.

● The values correspond to each specification and characteristics of a stand-alone motor. The speed – torque characteristics show the values when rated voltage is applied.

● A number indicating the gear ratio is specified where the box □ is located in the product name.

Speed – Torque Characteristics

Continuous Duty Region: Continuous operation is possible in this region.

Limited Duty Region: This region is used primarily when accelerating.

● 30 W

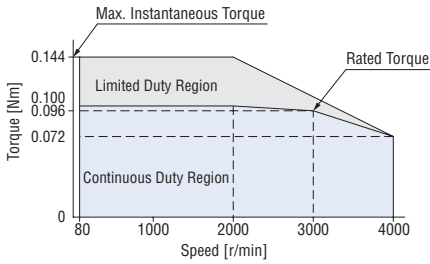

● 60 W

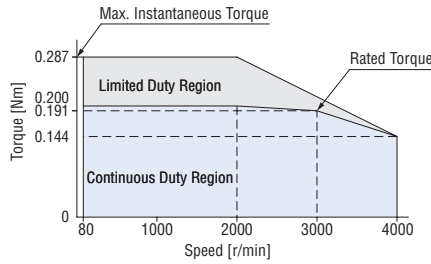

● 120 W

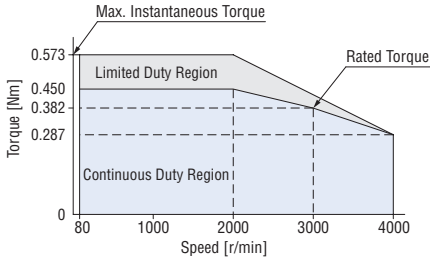

● 200 W

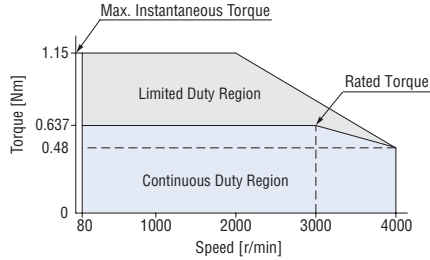

● 300 W

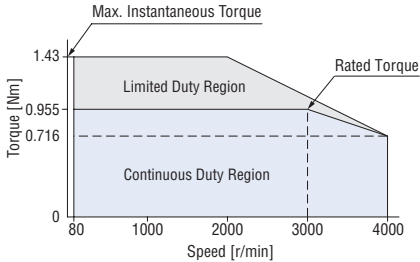

● The values correspond to each specification and characteristics of a stand-alone motor. The speed – torque characteristics show the values when rated voltage is applied.

Common Specifications

Item	Specifications	
	30 W, 60 W, 120 W	200 W, 300 W
Speed Setting Methods	Digital setting by dial 4 speed settings are possible	
Acceleration/Deceleration Time	Analog Setting: 0.1 - 15.0 s (set time from stopped state to rated speed) Common setting for acceleration/deceleration time with acceleration/deceleration time potentiometer* Digital Setting: 0.0 - 15.0 s (set time from current speed to setting speed) Individual acceleration times and deceleration times can be set for each operating data* *Acceleration time/deceleration time varies with the load condition of the motor.	
Input Signals	Photocoupler Input Input resistance: 5.7 kΩ Operated by Internal Power Supply: 5 VDC Connectable External DC Power Supply: 24 VDC -15 - +20% Current 100 mA or more Sink Input/Source Input Supported through external wiring	Photocoupler Input Input resistance: 6.6 kΩ Operated by Internal Power Supply: 5 VDC Connectable External DC Power Supply: 24 VDC -15 - +20% Current 100 mA or more Sink Input/Source Input Supported through external wiring
	Arbitrary signal assignment to X0 - X2 input (3 points) is possible. [FWD], [REV], [MO], M1, ALARM-RESET, EXT-ERROR, H-FREE []: Initial setting	Arbitrary signal assignment to IN0 - IN4 input (5 points) is possible. [FWD], [REV], [MO], [M1], [ALARM-RESET], EXT-ERROR, H-FREE []: Initial setting
Output Signals	Photocoupler and Open-Collector Output External Power Supply: 4.5 - 30 VDC 100 mA or less Sink Output/Source Output Supported through external wiring	Photocoupler and Open-Collector Output External Power Supply: 4.5 - 30 VDC 100 mA or less Sink Output/Source Output Supported through external wiring
	Arbitrary signal assignment to Y0, Y1 output (2 points) is possible. [ALARM-OUT1], [SPEED-OUT], ALARM-OUT2, MOVE, VA, WNG []: Initial setting	Arbitrary signal assignment to OUT0, OUT1 output (2 points) is possible. [ALARM-OUT1], [SPEED-OUT], ALARM-OUT2, MOVE, VA, WNG []: Initial setting
Protective Function	When the following protective functions are activated, the output from ALARM-OUT1 will turn off and the motor will perform a coasting stop. An alarm code will be displayed at the same time. (Instantaneous stop will only occur when an external stop is applied) Overcurrent, main circuit overcurrent, overvoltage, undervoltage, sensor error, overload, overspeed, EEPROM error, sensor error during initialization, operation stop during initialization, external stop	
Max. Extension Distance	Motor and driver distance: 10.5 m [when an accessory connection cable (for relay) is used]	
Time Rating	Continuous	

● Overload alarm detection time

The overload alarm is generated if the operation goes beyond the continuous duty region.
The detection time for this overload alarm can be set from 0.1 - 60.0 seconds. (Initial value: 30.0 seconds)
However, an alarm will be generated within 5 seconds in the following cases:

- When a load exceeding the limited duty region is applied
- When the output shaft is locked

General Specifications

Item	Motor	Driver
Insulation Resistance	100 MΩ or more when 500 VDC megger is applied between the windings and the case after continuous operation under normal ambient temperature and humidity.	The measured value is 100 MΩ or more when a 500 VDC megger is applied between the power supply terminal and the protective earth terminal and between the power supply terminal and the signal I/O terminal after continuous operation under normal ambient temperature and humidity.
Dielectric Voltage	Sufficient to withstand 1.5 kVAC at 50 Hz applied between the windings and the case for 1 minute after continuous operation under normal ambient temperature and humidity.	Sufficient to withstand 1.5 kVAC at 50 Hz applied between the power supply terminal and the protective earth terminal for 1 minute, and 1.5 kVAC at 50 Hz applied between the power supply terminal and the I/O signal terminal for 1 minute after continuous operation under normal ambient temperature and humidity.
Temperature Rise	The temperature rise of the windings is 50°C max. (60°C max. at 300 W) and that of the case surface is 40°C max. (50°C max. at 300 W), measured by the thermocouple method after rated continuous operation under normal ambient temperature and humidity*1.	The temperature rise of the heat sink is 50°C max., measured by the thermocouple method after rated continuous operation under normal ambient temperature and humidity.
Operating Environment	Ambient Temperature	0 - 40°C (Non-freezing)
	Ambient Humidity	85% max. (Non-condensing)
	Altitude	Max. of 1000 m above sea level
	Atmosphere	No corrosive gases or dust. Cannot be used in a radioactive area, magnetic field, vacuum, or other special environments.
	Vibration	Must not be subjected to continuous vibration or excessive shock. Conforms to IEC 60068-2-6, "Sine-wave vibration test method" Frequency range: 10 - 55 Hz Half amplitude: 0.15 mm Sweep direction: 3 directions (X, Y, Z) Number of sweeps: 20 times
Storage Condition*2	Ambient Temperature	-20 - +70°C (Non-freezing)
	Ambient Humidity	85% max. (Non-condensing)
	Altitude	Max. of 3000 m above sea level
Heat-Resistant Class	UL/CSA Standards: 105 (A), EN Standards: 120 (E)	-
Degree of Protection*3	When the cable is connected: IP66 (Excluding the installation surface of the round shaft type)	IP20

*1 For round shaft types, install on a heat sink (material: aluminum) of one of the following sizes to maintain a motor case surface temperature of 90°C or less.
 30 W type: 115×115 mm thickness 5 mm, 60 W type: 135×135 mm thickness 5 mm, 120 W type: 165×165 mm thickness 5 mm, 200 W type: 200×200 mm thickness 5 mm, 300 W type: 250×250 mm thickness 6 mm

*2 The storage condition applies to short periods such as the period during transport.

*3 The IP display indicating watertight and dust-resistant performance is regulated by IEC 60529 and IEC 60034-5.

Note

● Do not measure insulation resistance or perform a dielectric strength test while the motor and driver are connected.

Motor Materials and Surface Treatment

- Materials Case: Aluminum
Output shaft: Stainless steel
Screws: Stainless steel (externally facing screws only; protective earth terminals excluded)
- Surface treatment Case: Paint (installation surface excluded)

Permissible Torque of Combination Types

Combination Type with a Parallel Shaft Gearhead

Unit: Nm

Output Power [W]	Motor Shaft Speed	Gear Ratio							
		5	10	15	20	30	50	100	200
30	At 80 - 2000 r/min	0.45	0.9	1.4	1.8	2.6	4.3	6	6
	At 3000 r/min	0.43	0.86	1.3	1.7	2.5	4.1	6	6
	At 4000 r/min	0.32	0.65	0.97	1.3	1.9	3.1	5.4	5.4
60	At 80 - 2000 r/min	0.9	1.8	2.7	3.6	5.2	8.6	16	16
	At 3000 r/min	0.86	1.7	2.6	3.4	4.9	8.2	16	16
	At 4000 r/min	0.65	1.3	1.9	2.6	3.7	6.2	12.4	14
120	At 80 - 2000 r/min	2	4.1	6.1	8.1	11.6	19.4	30	30
	At 3000 r/min	1.7	3.4	5.2	6.9	9.9	16.4	30	30
	At 4000 r/min	1.3	2.6	3.9	5.2	7.4	12.3	24.7	27
200	At 80 - 3000 r/min	2.9	5.7	8.6	11.5	16.4	27.4	51.6	70
	At 4000 r/min	2.2	4.3	6.5	8.6	12.4	20.6	38.9	63
300	At 80 - 3000 r/min	4.3	8.6	12.9	17.2	24.6	41.1	70	-
	At 4000 r/min	3.2	6.4	9.7	12.9	18.5	30.8	58	-

● A colored indicates gear shaft rotation in the same direction as the motor shaft. Other models rotate in the opposite direction.

Output Shaft Speed of Combination Types

Unit: r/min

Motor Shaft Speed	Gear Ratio							
	5	10	15	20	30	50	100	200
80 r/min	16	8	5.3	4	2.7	1.6	0.8	0.4
2000 r/min	400	200	133	100	66.7	40	20	10
3000 r/min	600	300	200	150	100	60	30	15
4000 r/min	800	400	267	200	133	80	40	20

■ Permissible Radial Load and Permissible Axial Load

● Combination Type with a Parallel Shaft Gearhead

Output Power [W]	Gear Ratio		Permissible Radial Load		Permissible Axial Load N
			10 mm from the end of the output shaft N	20 mm from the end of the output shaft N	
30	5	At 80 - 3000 r/min	100	150	40
		At 4000 r/min	90	110	
	10, 15, 20	At 80 - 3000 r/min	150	200	
		At 4000 r/min	130	170	
	30, 50, 100, 200	At 80 - 3000 r/min	200	300	
		At 4000 r/min	180	230	
60	5	At 80 - 3000 r/min	200	250	100
		At 4000 r/min	180	220	
	10, 15, 20	At 80 - 3000 r/min	300	350	
		At 4000 r/min	270	330	
	30, 50, 100, 200	At 80 - 3000 r/min	450	550	
		At 4000 r/min	420	500	
120	5	At 80 - 3000 r/min	300	400	150
		At 4000 r/min	230	300	
	10, 15, 20	At 80 - 3000 r/min	400	500	
		At 4000 r/min	370	430	
	30, 50, 100, 200	At 80 - 3000 r/min	500	650	
		At 4000 r/min	450	550	
200 300	5, 10, 15, 20	At 80 - 3000 r/min	550	800	200
		At 4000 r/min	500	700	
	30, 50	At 80 - 3000 r/min	1000	1250	300
		At 4000 r/min	900	1100	
	100, 200*	At 80 - 3000 r/min	1400	1700	400
		At 4000 r/min	1200	1400	

*Only when output power is 200 W

● Round Shaft Type

Output Power [W]	Permissible Radial Load		Permissible Axial Load
	10 mm from the end of the output shaft N	20 mm from the end of the output shaft N	
30 60	80	100	Half of motor mass max.
120 200 300	150	170	

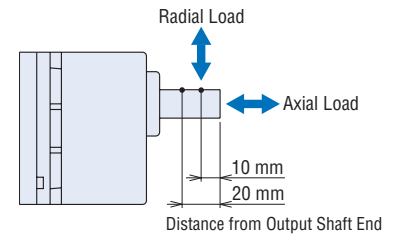

■ Permissible Inertia J of Combination Types

● Combination Type with a Parallel Shaft Gearhead

Unit: $\times 10^{-4} \text{ kgm}^2$

Output Power [W]		Gear Ratio							
		5	10	15	20	30	50	100	200
30		12	50	110	200	370	920	2500	5000
	When instantaneous stop or instantaneous bi-directional operation is performed*	1.55	6.2	14	24.8	55.8	155	155	155
60		22	95	220	350	800	2200	6200	12000
	When instantaneous stop or instantaneous bi-directional operation is performed*	5.5	22	49.5	88	198	550	550	550
120		45	190	420	700	1600	4500	12000	25000
	When instantaneous stop or instantaneous bi-directional operation is performed*	25	100	225	400	900	2500	2500	2500
200		100	460	1000	1700	3900	9300	18000	37000
	When instantaneous stop or instantaneous bi-directional operation is performed*	50	200	450	800	1800	5000	5000	5000
300		100	460	1000	1700	3900	9300	18000	-
	When instantaneous stop or instantaneous bi-directional operation is performed*	50	200	450	800	1800	5000	5000	-

*It is also applicable when digitally setting the deceleration time to below 0.1 seconds.

Dimensions (Unit = mm)

- The motor dimensions in this catalogue are the dimensions when a separately sold connection cable (the color in the diagrams) is attached.
- Listed masses do not include the mass of the connection cable.
- Refer to page 20 for the dimensions and masses of connection cables.
- Installation screws are included with the combination type. Dimensions for installation screws → Page 20
- A number indicating the gear ratio is specified where the box is located in the product name.

Motor

◇ 30 W

● Combination Type with a Parallel Shaft Gearhead

Motor Product Name	Gearhead Product Name	Gear Ratio	L	Mass [kg]
BLM230HP-GFV	GFV2GS	5 - 20	34	0.85
		30 - 100	38	
		200	43	

- When connection cable is attached for pull-out on output shaft side

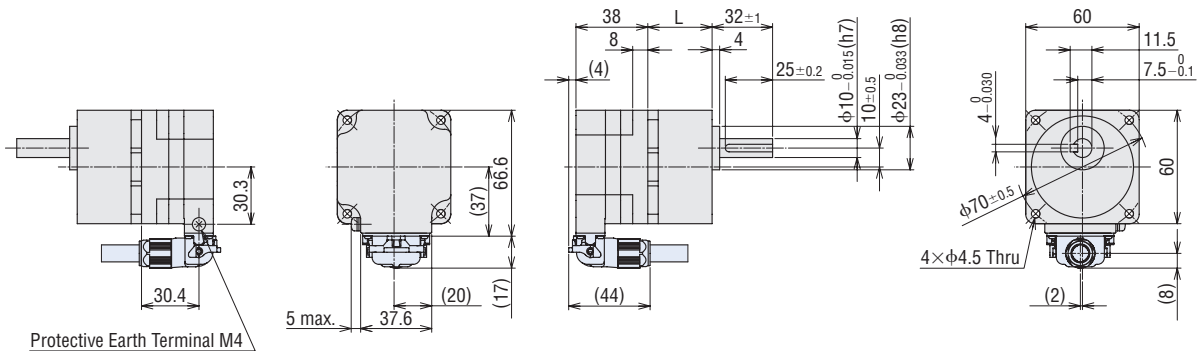

- At the time of shipment, a key is fixed in the key slot of the gearhead shaft.

- When connection cable is attached for pull-out on rear of the motor
- For vertical pull-out

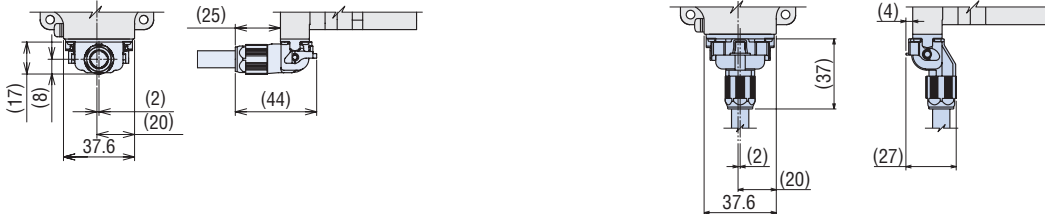

● Round Shaft Type

BLM230HP-AS

Mass: 0.35 kg

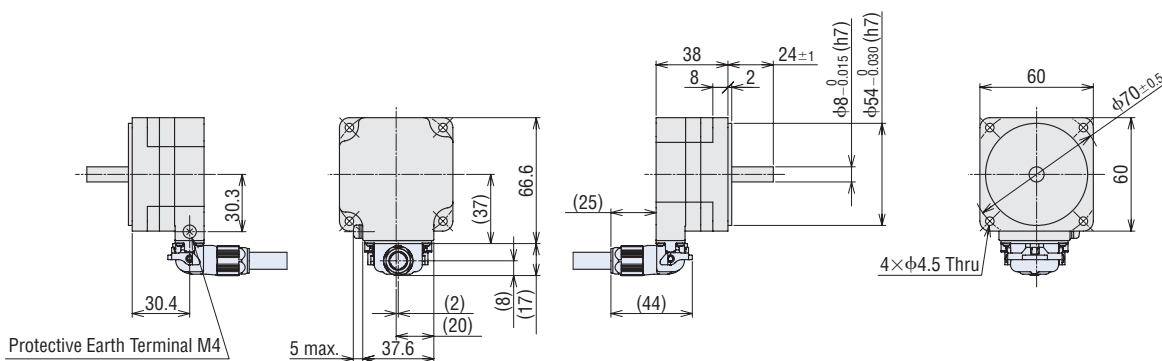

◇ 60 W

● Combination Type with a Parallel Shaft Gearhead

Motor Product Name	Gearhead Product Name	Gear Ratio	L	Mass [kg]
BLM460SHP-GFV	GFV4G□S	5 - 20	41	1.6
		30 - 100	46	
		200	51	

● When connection cable is attached for pull-out on output shaft side

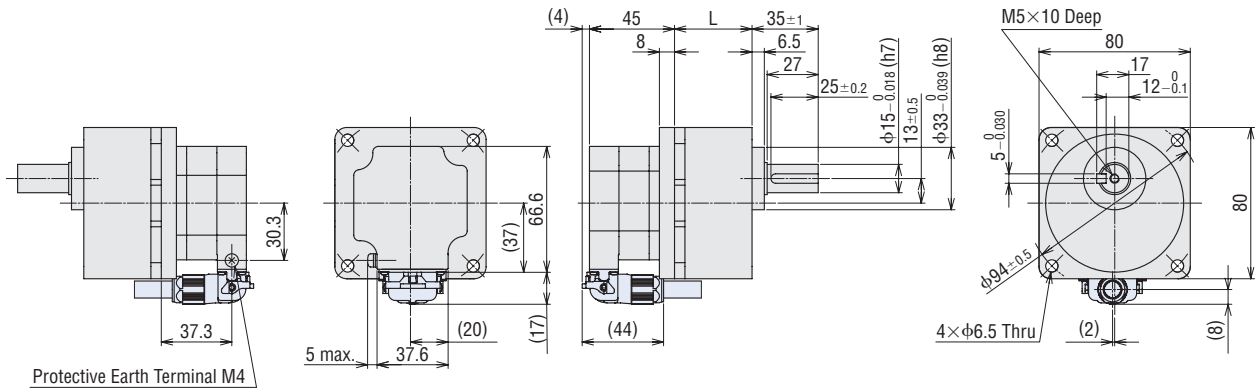

● At the time of shipment, a key is fixed in the key slot of the gearhead shaft.

● When connection cable is attached for pull-out on rear of the motor ● For vertical pull-out



● Round Shaft Type

BLM260HP-AS

Mass: 0.52 kg

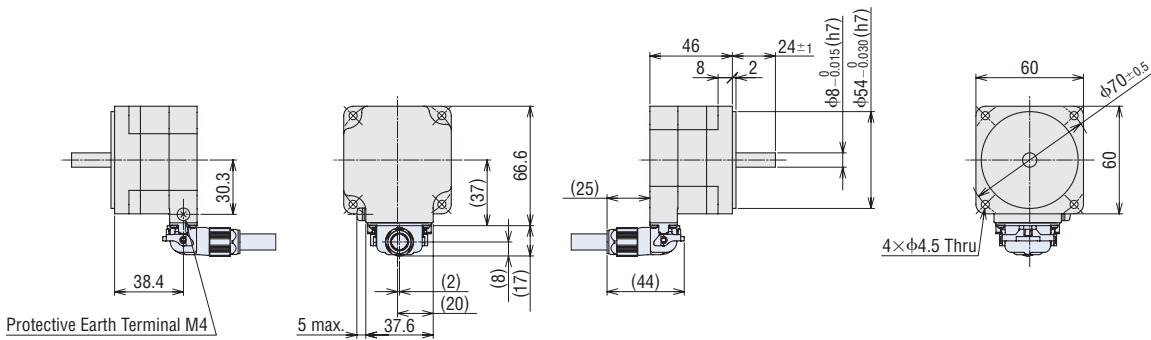

◇ 120 W

● Combination Type with a Parallel Shaft Gearhead

Motor Product Name	Gearhead Product Name	Gear Ratio	L	Mass [kg]
BLM5120HP-GFV	GFV5G□S	5 - 20	45	2.6
		30 - 100	58	
		200	64	

● When connection cable is attached for pull-out on output shaft side

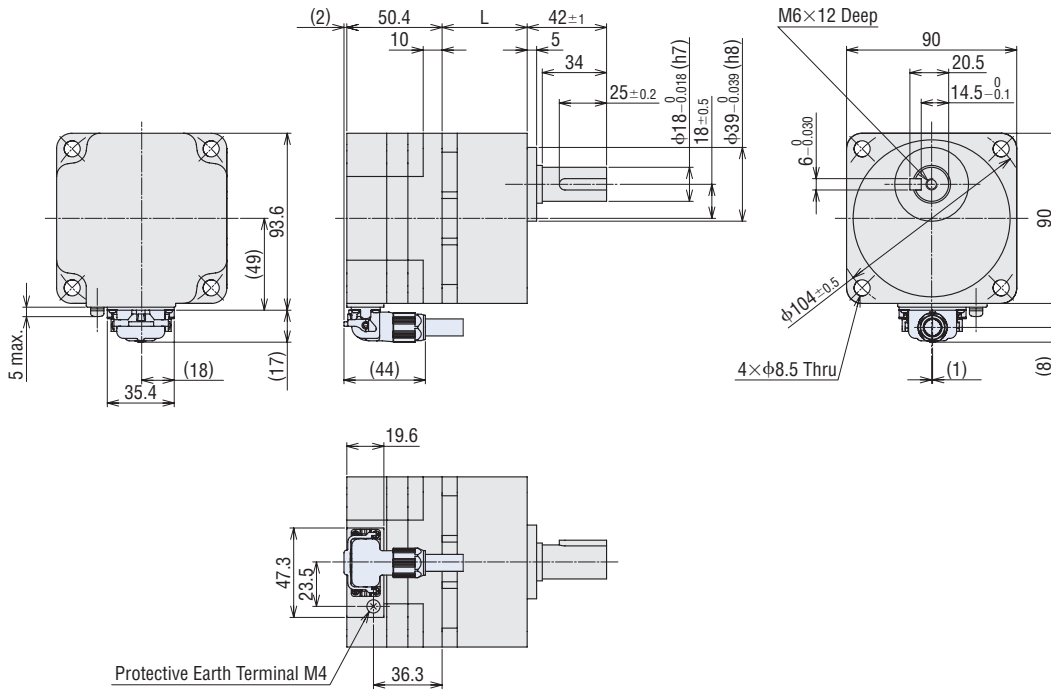

● At the time of shipment, a key is fixed in the key slot of the gearhead shaft.

● When connection cable is attached for pull-out on rear of the motor

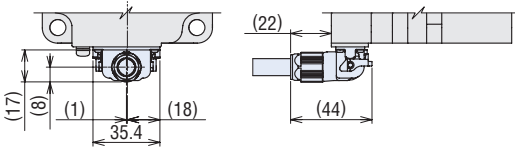

● For vertical pull-out

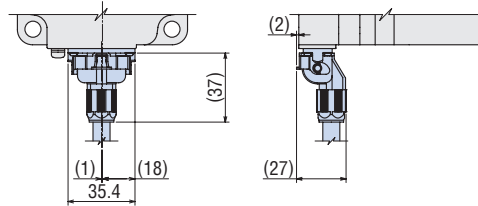

● Round Shaft Type

BLM5120HP-AS

Mass: 1.1 kg

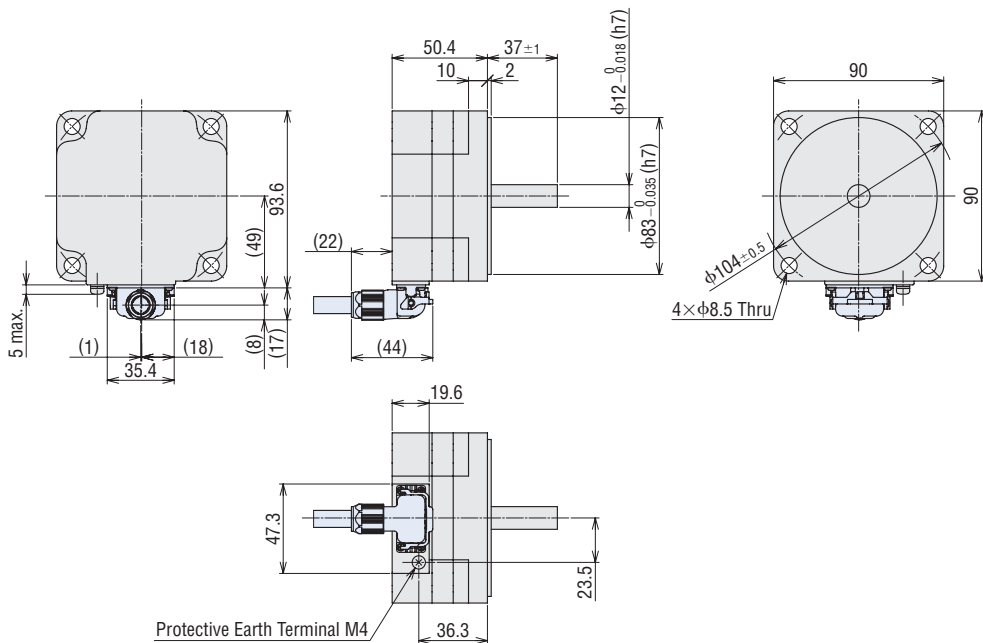

◇ 200 W

● Combination Type with a Parallel Shaft Gearhead

Motor Product Name	Gearhead Product Name	Gear Ratio	L	Mass [kg]
BLM6200SHP-GFV	GFV6G□S	5 - 20	60	4.7
		30, 50	72	
		100, 200	86	

● When connection cable is attached for pull-out on output shaft side

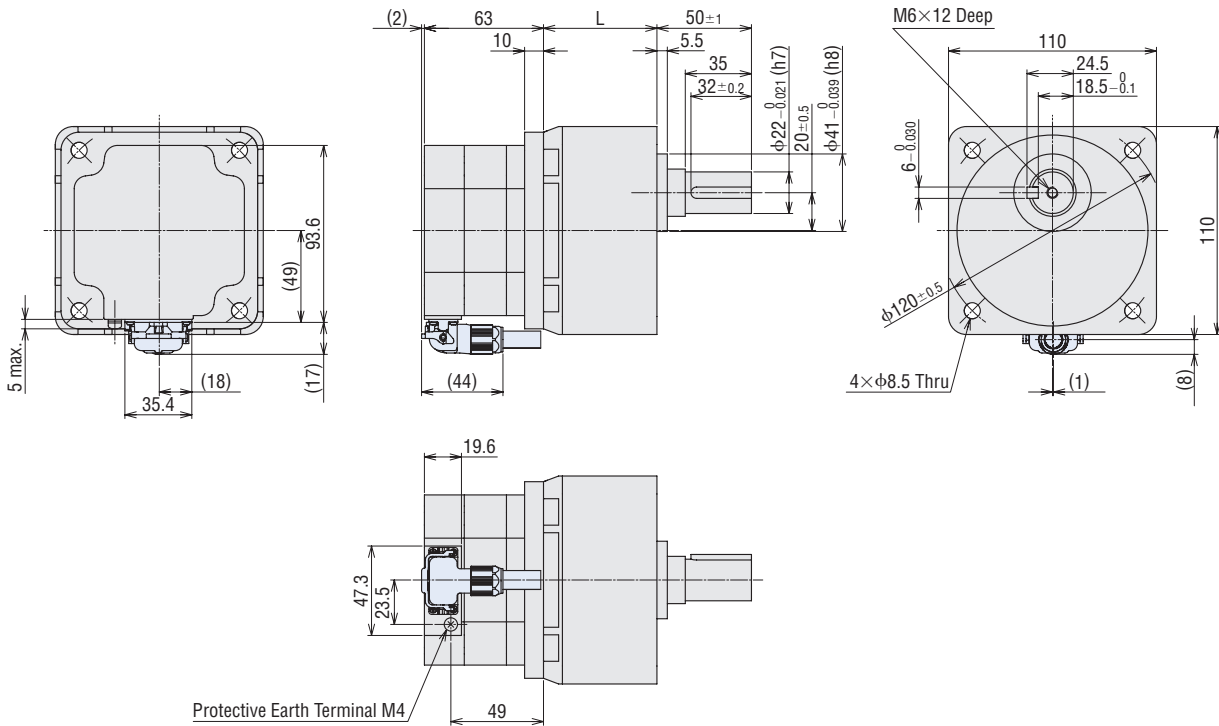

● At the time of shipment, a key is fixed in the key slot of the gearhead shaft.

● When connection cable is attached for pull-out on rear of the motor

● For vertical pull-out

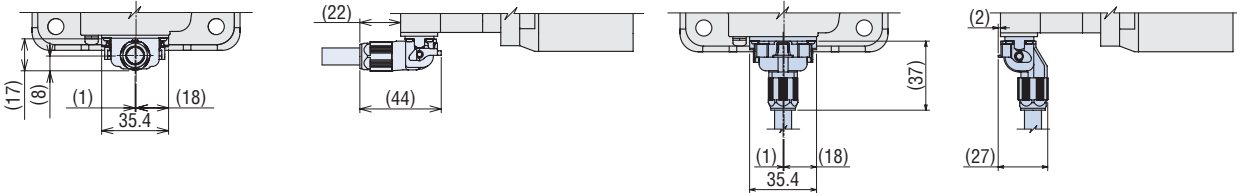

● Round Shaft Type

BLM5200HP-AS

Mass: 1.6 kg

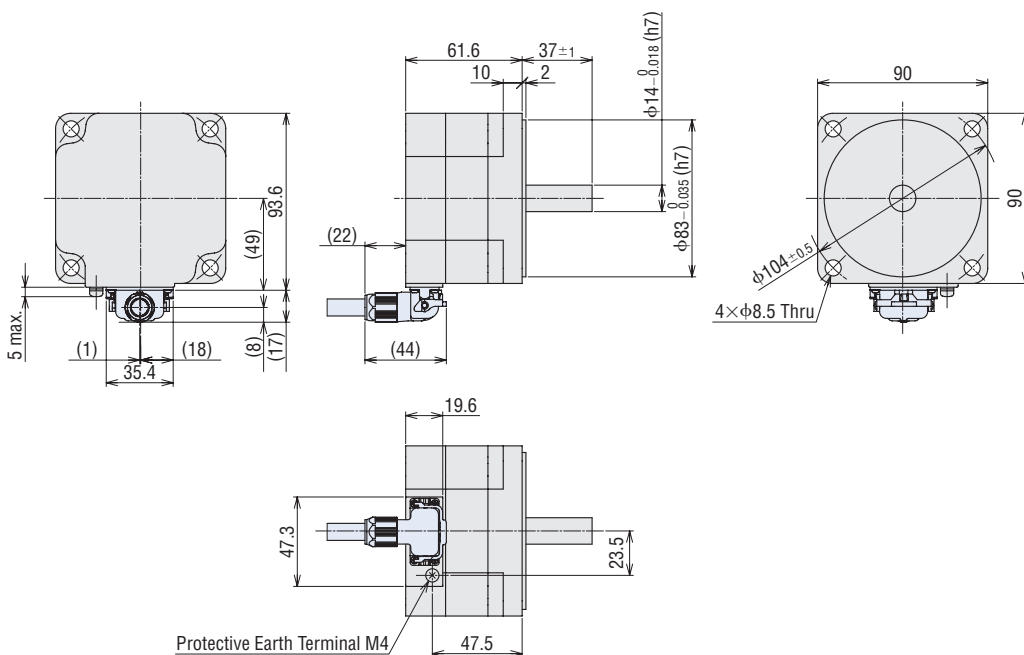

◇ 300 W

● Combination Type with a Parallel Shaft Gearhead

Motor Product Name	Gearhead Product Name	Gear Ratio	L	Mass [kg]
BLM6300SHP-GFV	GFV6G□S	5 - 20	60	5.2
		30, 50	72	
		100	86	

● When connection cable is attached for pull-out on output shaft side

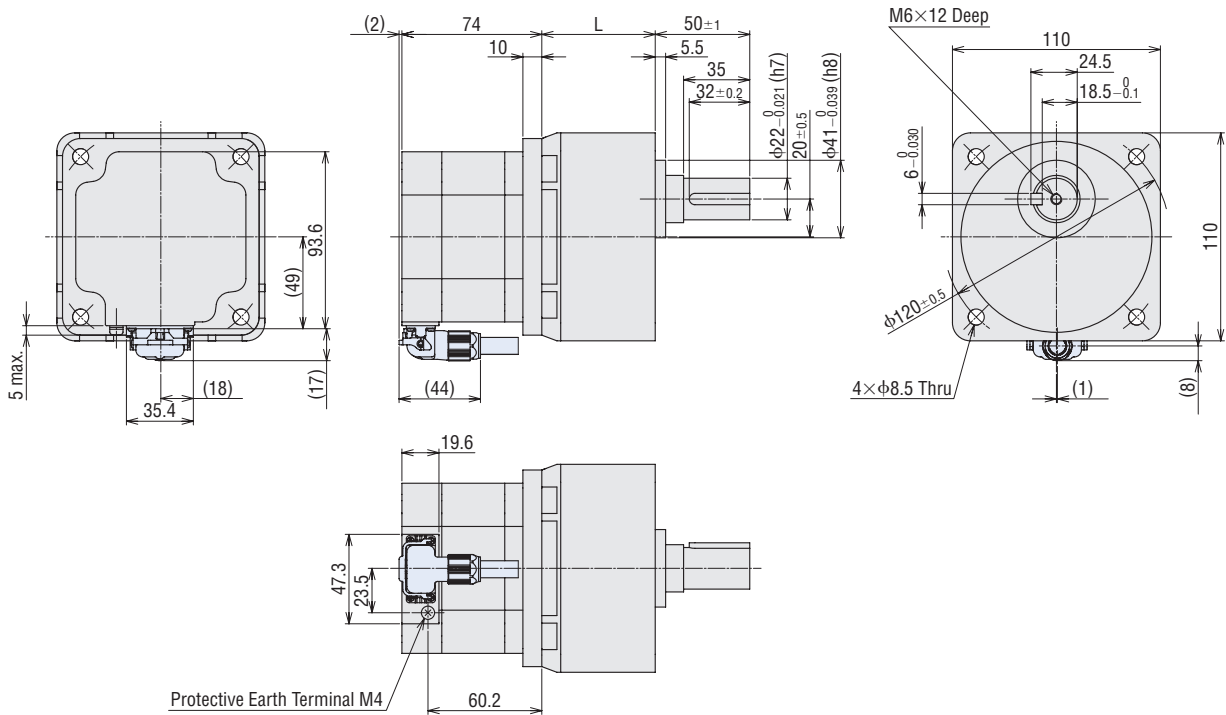

● At the time of shipment, a key is fixed in the key slot of the gearhead shaft.

● When connection cable is attached for pull-out on rear of the motor

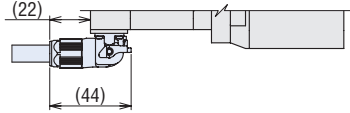
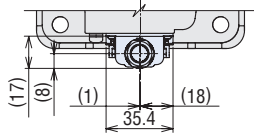

● For vertical pull-out

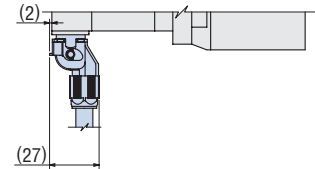
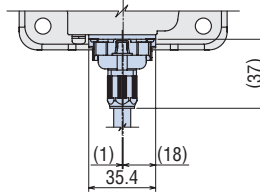

● Round Shaft Type

BLM5300HP-AS

Mass: 2.1 kg

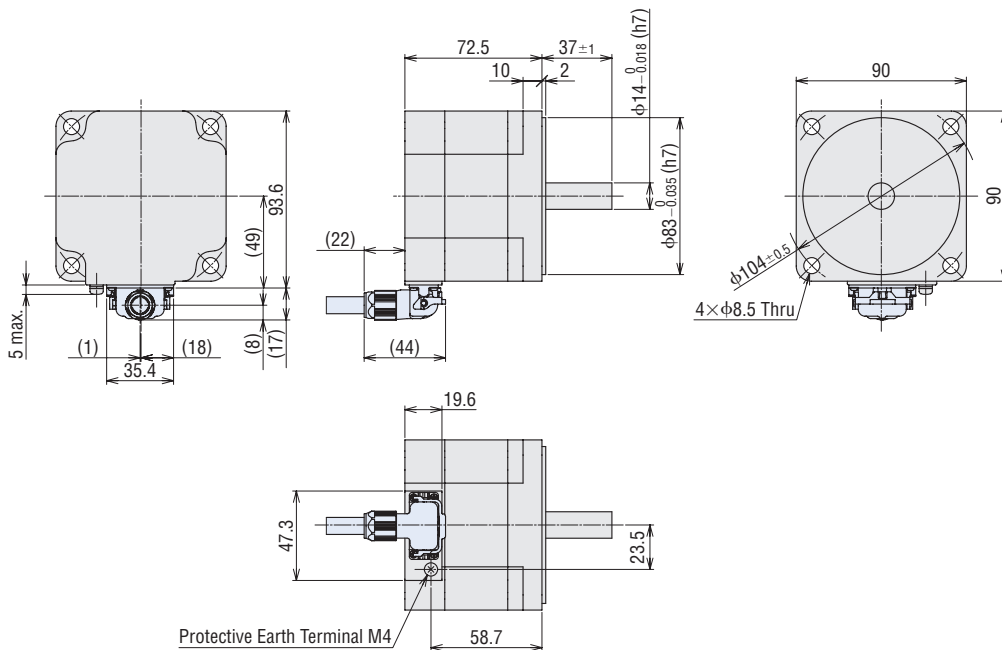

● Drivers

◇ 30 W, 60 W, 120 W

BMUD30-A2, BMUD30-C2, BMUD60-A2, BMUD60-C2, BMUD120-A2, BMUD120-C2

Mass: 0.4 kg

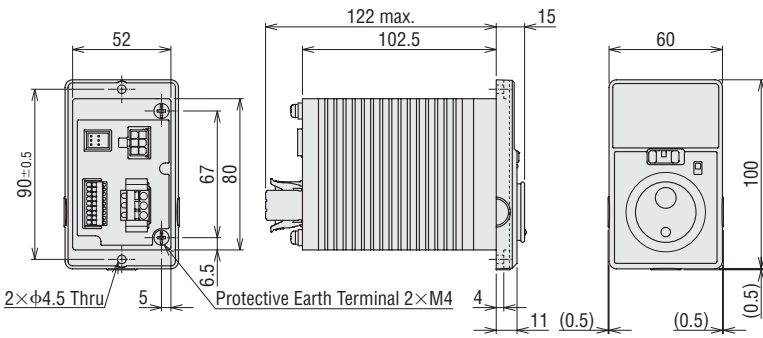

● Panel Cut-Out Dimension for Driver

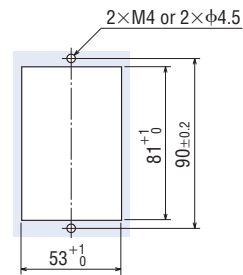

◇ 200 W, 300 W

BMUD200-C, BMUD300-C

Mass: 0.8 kg

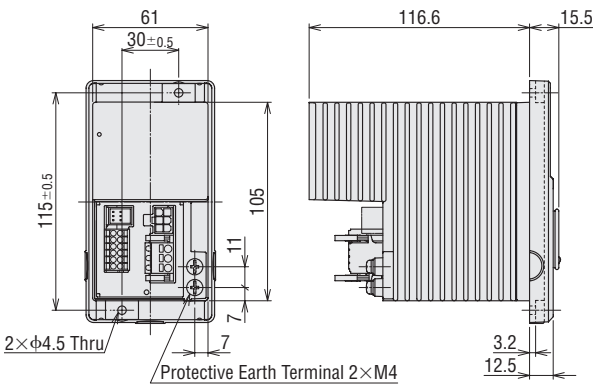

● Panel Cut-Out Dimension for Driver

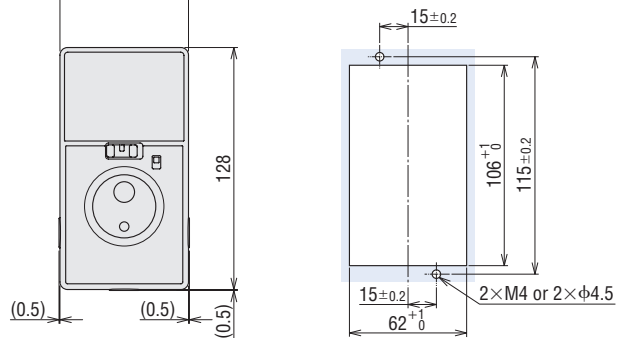

● Connection Cables

Length L [m]	Product Name			Mass [kg]
	Pull-out on output shaft side	Pull-out on rear of the motor	Vertical Pull-out	
0.5	CC005KHBLF	CC005KHBLB	CC005KHBLV	0.08
1	CC010KHBLF	CC010KHBLB	CC010KHBLV	0.12
1.5	CC015KHBLF	CC015KHBLB	CC015KHBLV	0.2
2	CC020KHBLF	CC020KHBLB	CC020KHBLV	0.25
2.5	CC025KHBLF	CC025KHBLB	CC025KHBLV	0.32
3	CC030KHBLF	CC030KHBLB	CC030KHBLV	0.38
4	CC040KHBLF	CC040KHBLB	CC040KHBLV	0.49
5	CC050KHBLF	CC050KHBLB	CC050KHBLV	0.62
7	CC070KHBLF	CC070KHBLB	CC070KHBLV	0.86
10	CC100KHBLF	CC100KHBLB	CC100KHBLV	1.2

● Pull-out on output shaft side, Pul-out on rear of the motor

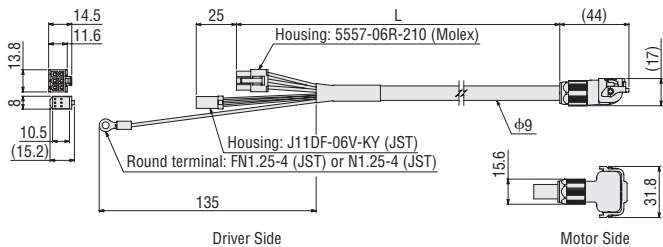

● Vertical pull-out

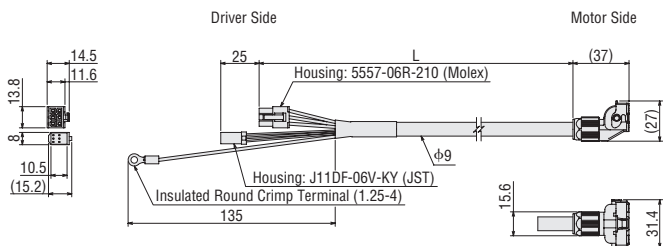

■ Installation Screw Dimensions

● Combination Type with a Parallel Shaft Gearhead

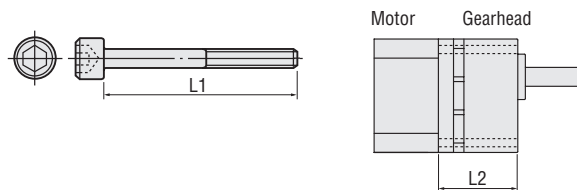

Gearhead Product Name	Installation Screws		L2 [mm]
	L1 [mm]	Screw Size	
GFV2G55 - 20S	50	M4 P0.7	42
GFV2G30S - 100S	55		46
GFV2G200S	60	M6 P1.0	51
GFV4G55 - 20S	60		49
GFV4G30S - 100S	65	M8 P1.25	54
GFV4G200S	70		59
GFV5G55 - 20S	70	M8 P1.25	55
GFV5G30S - 100S	85		68
GFV5G200S	90	M8 P1.25	74
GFV6G55 - 20S	85		70
GFV6G30S - 50S	100	M8 P1.25	82
GFV6G100S - 200S	110		96

● Installation Screws: Plain washer, spring washer included (4 each)

● The installation screw material is stainless steel.

Connection and Operation (30 W, 60 W, 120 W)

Names and Functions of Driver Parts

Display

Displays the monitor contents, alarm, etc.

Dial

Changes the speed and parameters. The value is set when the dial is pressed after changes are made.



[Front of Driver]

Operating Switch

The motor is started by setting it to the "RUN" position. Setting it to the "STAND-BY" position stops the motor.

Rotation Direction Switch

Changes the rotation direction of the motor.

Front Panel

Sensor Signal Connector (CN3)

Connects to the sensor connector (black) on the motor.

I/O Signal Connector (CN4)

Connects the I/O signals

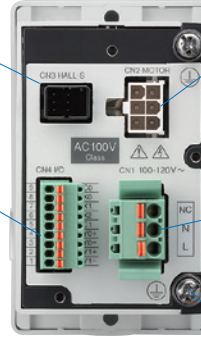

[Back of Driver]

Motor Connector (CN2)

Connects to the motor connector (white) on the motor.

Main Power Connector (CN1)

Connects the main power supply.

Protective Earth Terminals (2 locations)
Ground either one of the protective earth terminals.

When Front Panel is Removed

MODE Key

Changes the operating mode.



FUNCTION Key

Changes the indication and functions for the operating mode.

Acceleration/Deceleration Time Potentiometer

Sets the acceleration time for starting the motor and deceleration time for motor standstill. Setting Range: 0.1 s - 15.0 s

Installation Holes (2 locations)

Extended Functions

These settings can be made with key operations after removing the front panel.

Operating Mode	Details
Monitoring	Speed, load factor, operating data number, alarm code, warning, I/O monitor
Data	4 data points Operating speed, acceleration time, deceleration time, reset
Parameters	Gear ratio, speed increasing ratio, initial panel display, initial operation prohibition alarm, initial operation prohibition alarm cancellation method selection, analog acceleration/deceleration, speed upper limit/lower limit setting function, simple holding selection, external operating signal input, input function selection, output function selection, overload alarm detection time except when shaft is locked, overload warning level, speed attainment band, parameter mode reset

Main Power Connector (CN1)

Connects the main power supply. Connect a power supply that matches the power supply voltage to be used.

Single-phase 100-120 VAC

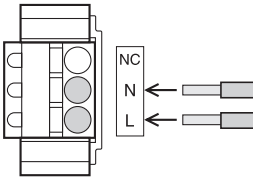

Single-phase 200-240 VAC

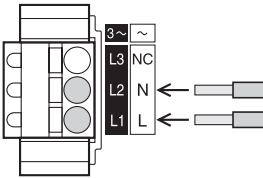

Three-phase 200-240 VAC

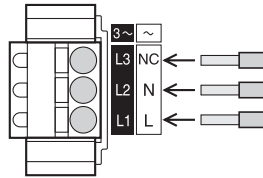

Applicable Lead Wire Size

AWG18 - 14 (0.75 - 2.0 mm²)

Operation with the Driver Only

Run/Stop

When the operating switch is set to the "RUN" position, the motor will start.

When it is returned to "STAND-BY," the motor will decelerate to a stop.

Speed Setting Method

Set the motor speed by using the dial.

Turning the dial slowly to the right increases the speed by 1 r/min increments, while turning it to the left reduces the speed by 1 r/min increments.

Turning the dial quickly increases the speed variation.

Pressing the dial sets the speed.



Operate with the operating switch

Set the speed with the dial

Operating Switch



● Operation by External Signals

◇ Operating Method

- Using the built-in power supply in the driver, the motor is operated through signals from external sources (switches, relays, etc.). Connect Pins No. 5 - 8 of the I/O signal connector (CN4) as shown in the figure to the right.
- When operating using external signals, change the parameter setting in the "External Operating Signal Input." Refer to the operating manual for details.
- Multistep speed-change operation up to 4 steps can be performed.

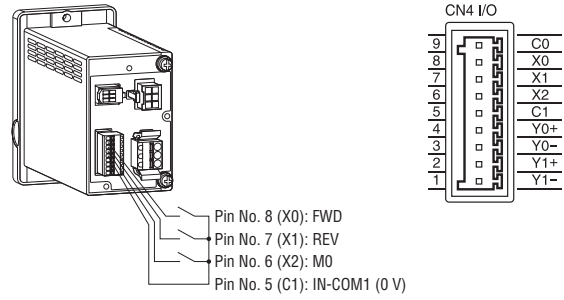

● I/O Signal Connector (CN4)

Pin No.	Terminal Name	Function*	Description
9	C0	IN-COM0	Input signal common (for external power supply)
8	X0	[FWD]	The motor rotates in the forward direction when "ON".
7	X1	[REV]	The motor rotates in the reverse direction when "ON".
6	X2	[MO]	Selects the operating data.
5	C1	IN-COM1	Input signal common (for internal power supply: 0 V)
4	Y0+	[SPEED-OUT]	30 pulses are output when the motor output shaft makes one rotation.
3	Y0-		
2	Y1+	[ALARM-OUT1]	Turns OFF when an alarm activates. (Normally closed)
1	Y1-		

- Applicable Lead Wire Size
AWG26 - 20 (0.14 - 0.5 mm²)

*The text inside the [] represents the factory default function assignment.

The following signals can be assigned as necessary to 3 input signal terminals (X0 - X2) and 2 output signal terminals (Y0, Y1).

3 of the 7 input signals (FWD, REV, MO, M1, ALARM-RESET, EXT-ERROR, H-FREE)

2 of the 6 output signals (ALARM-OUT1, SPEED-OUT, ALARM-OUT2, MOVE, VA, WNG)

◇ Connection Example Using Switches and Relays

The figure shows a connection example when operating a motor with a contact switch, such as switches and relays. (Single-phase 200-240 VAC)

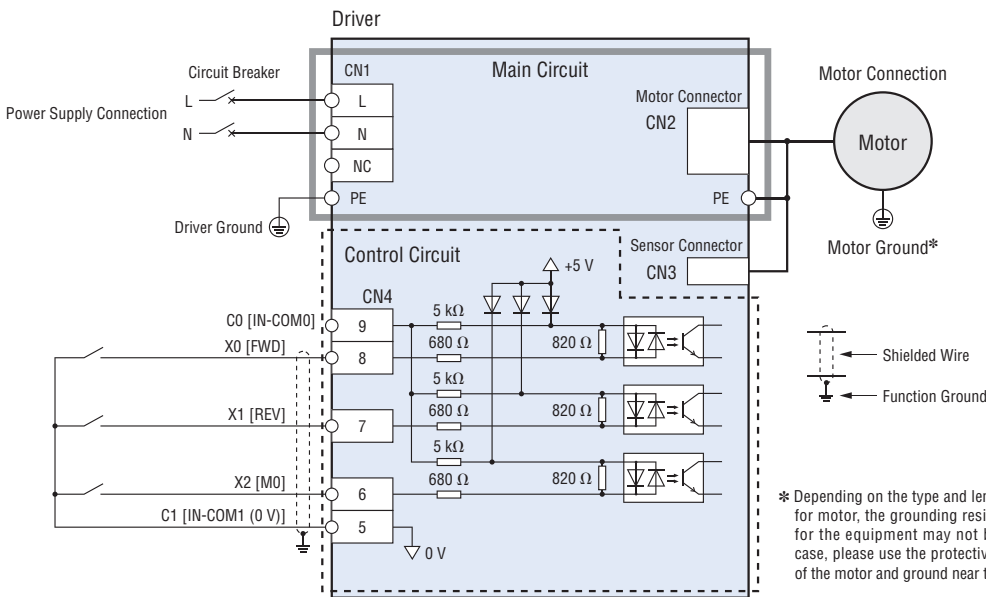

* Depending on the type and length of the cable for motor, the grounding resistance standard for the equipment may not be met. In such case, please use the protective earth terminal of the motor and ground near the motor.

◇ Timing Chart

This is when the "External Operating Signal Input" parameter setting is "ON" and the rotation direction switch is set to "FWD."

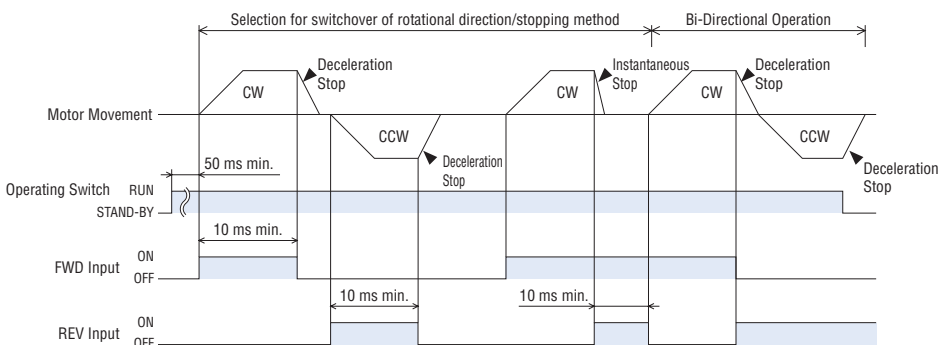

- Switching the FWD input to ON will cause the motor to rotate clockwise as viewed from the motor shaft side, while switching the REV input to ON will cause the motor to rotate counterclockwise. Turning it OFF decelerates the motor to a stop.

- If the FWD input and REV input are turned ON simultaneously, the motor will stop instantaneously.

- With the combination type, the rotation direction varies according to the gear ratio of the gearhead.

◇ I/O Signal and Programmable Controller Connection Examples

This is a connection example for operating a motor using a transistor output type programmable controller.

● Sink Logic

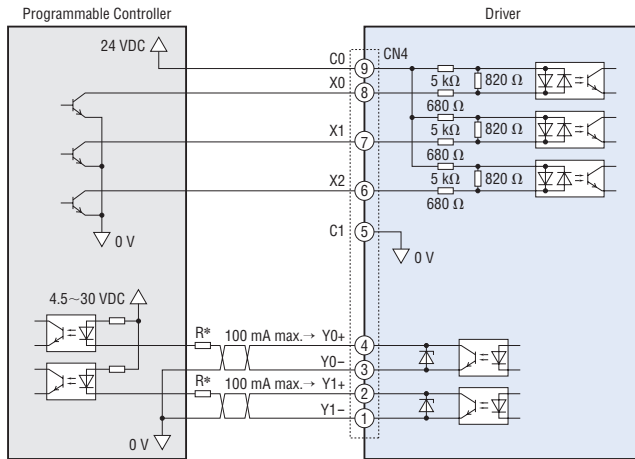

● Source Logic

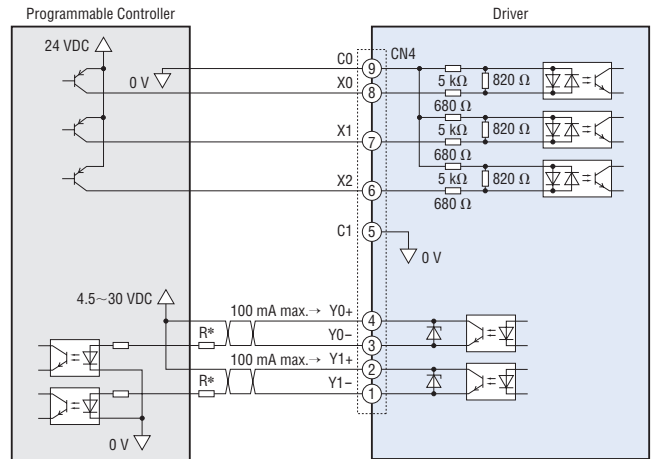

*Recommended Resistance Value
 24 VDC: 680 Ω - 2.7 kΩ (2 W)
 5 VDC: 150 Ω - 560 Ω (0.5 W)

[Note]

Maintain the current value of Y0 and Y1 at 100 mA or less. If this current value is exceeded, connect the limiting resistor R.

◇ When an External Control Device with a Built-In Clamp Diode is Used

If an external control device with a built-in clamp diode is connected and the external control device is turned off when the driver power is on, current may flow, and the motor may turn. Because the current capacity between the driver and external control device is different, the motor may also rotate when their power supplies are turned ON/OFF simultaneously. To turn the power off, turn off the driver and then the external control device. To turn the power on, turn on the external control device and then the driver.

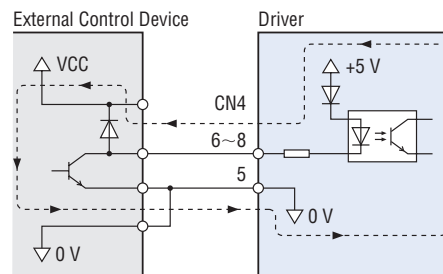

◇ When Multistep Speed-Change Operation is Used

Multistep speed-change operation is possible by switching the M0 and M1 inputs ON / OFF.

● Operating Condition Example

Operating Data No.	M0	M1	Speed [r/min]
0	OFF	OFF	3000
1	ON	OFF	1000
2	OFF	ON	2000
3	ON	ON	500

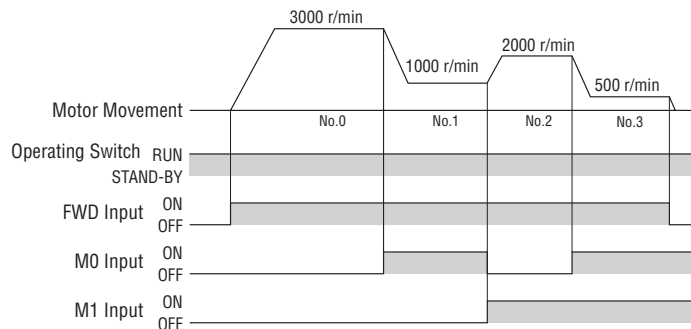

Connection and Operation (200 W, 300 W)

Names and Functions of Driver Parts

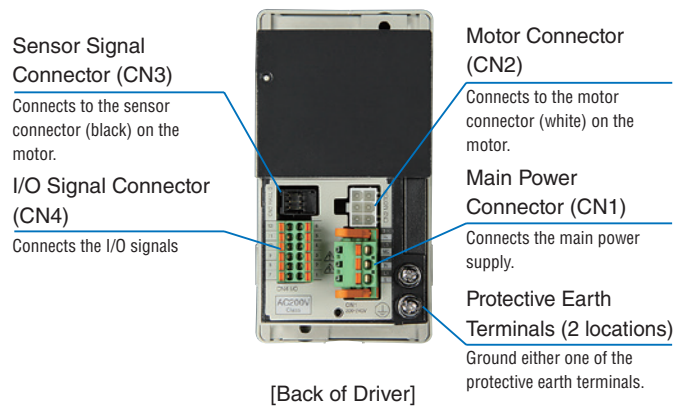
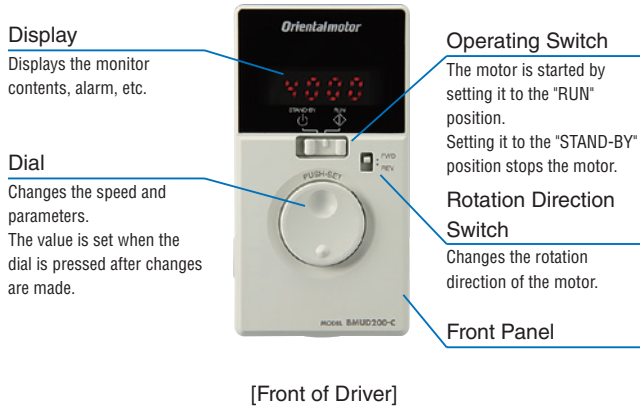

When Front Panel is Removed

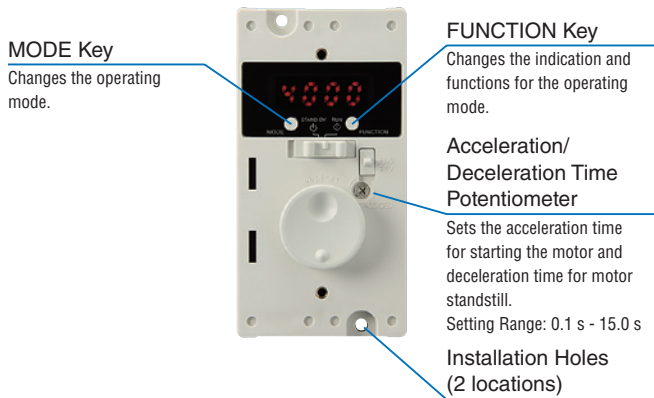

Extended Functions

These settings can be made with key operations after removing the front panel.

Operating Mode	Details
Monitoring	Speed, load factor, operating data number, alarm, warning, I/O monitor
Data	4 data points Speed, acceleration time, deceleration time, reset
Parameters	Gear ratio, speed increasing ratio, initial panel display, initial operation prohibition alarm, initial operation prohibition alarm cancellation method selection, analog acceleration/deceleration, speed upper limit/lower limit setting function, simple holding selection, external operating signal input, input function selection, output function selection, overload alarm detection time except when shaft is locked, overload warning level, speed attainment band, parameter mode reset

Main Power Connector (CN1)

Connects the main power supply. Connect a power supply that matches the power supply voltage to be used.

Single-phase 200-240 VAC

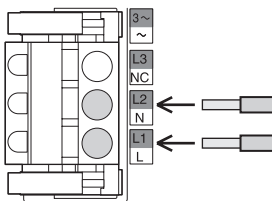

Three-phase 200-240 VAC

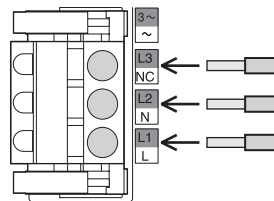

For the 300 W type, only L1, L2, and L3 are shown.

Applicable Lead Wire Size

AWG18 - 14 (0.75 - 2.0 mm²)

Operation with the Driver Only

Run/Stop

When the operating switch is set to the "RUN" position, the motor will start.

When it is returned to "STAND-BY," the motor will decelerate to a stop.

Speed Setting Method

Set the motor speed by using the dial.

Turning the dial slowly to the right increases the speed by 1 r/min increments, while turning it to the left reduces the speed by 1 r/min increments.

Turning the dial quickly increases the speed variation.

Pressing the dial sets the speed.

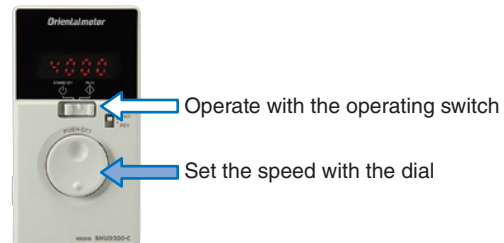

Operating Switch



● Operation by External Signals

◇ Operating Method

- Using the built-in power supply in the driver, the motor is operated through signals from external sources (switches, relays, etc.). Connect pins No.1 - 5 and No.7 of the I/O signal connector (CN4) as shown in the chart below.
- When operating using external signals, change the "external operation input signal" parameter. For more details, refer to the operating manual.
- Multistep speed change operations involving up to 4 steps are possible.

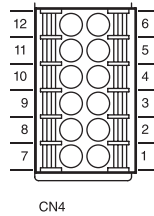

● I/O Signal Connector (CN4)

Pin No.	Signal Name	Function*	Description
1	IN4	[ALARM-RESET]	Alarms are reset.
2	IN3	[M1]	Selects the operating data.
3	IN2	[M0]	
4	IN1	[REV]	The motor rotates in the reverse direction when "ON".
5	IN0	[FWD]	The motor rotates in the forward direction when "ON".
6	IN-COM0	IN-COM0	Input signal common (for external power supply)
7	IN-COM1	IN-COM1	Input signal common (for internal power supply: 0 V)
8	N.C.	N.C.	No connection.
9	OUT1-	[ALARM-OUT1]	Turns OFF when an alarm activates. (Normally closed)
10	OUT1+		
11	OUT0-	[SPEED-OUT]	30 pulses are output with each rotation of the motor output shaft.
12	OUT0+		

● Applicable Lead Wire Size AWG24 - 18 (0.2 - 0.75 mm²)

*Text inside the [] represents the factory default function assignment.
The following signals can be assigned as necessary to 5 input signal terminals (IN0 - IN4) and 2 output signal terminals (OUT0, OUT1).
5 out of the 7 possible input signals (FWD, REV, M0, M1, ALARM-RESET, EXT-ERROR, H-FREE)
2 out of the 6 possible output signals (ALARM-OUT1, SPEED-OUT, ALARM-OUT2, MOVE, VA, WNG)

◇ Connection Example using Switches and Relays

The figure shows a connection example when operating a motor with a contact switch, such as switches and relays. (Single-phase 200-240 VAC)

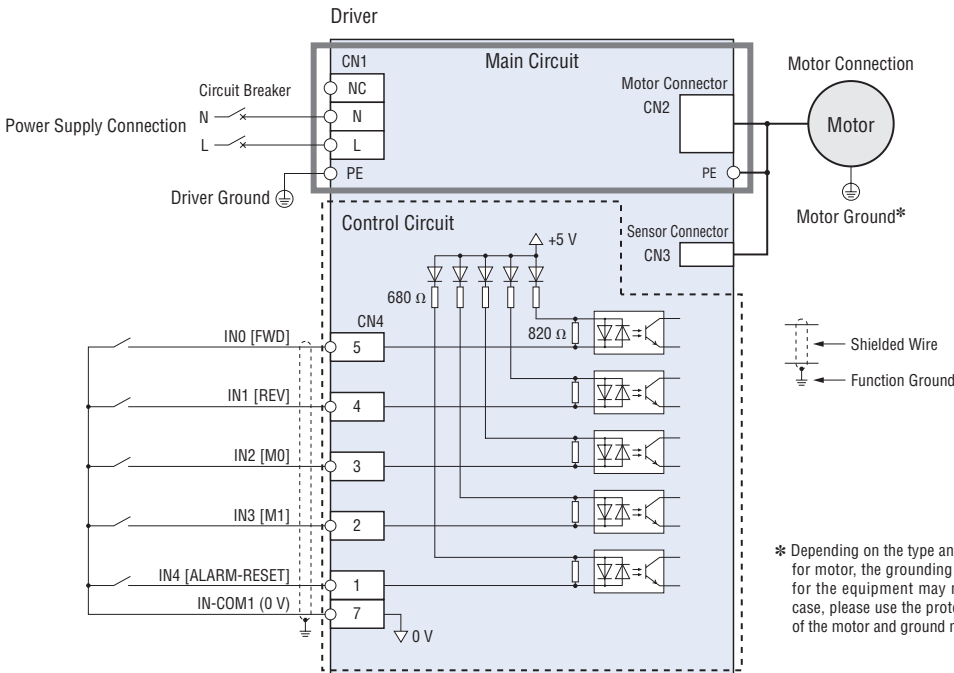

◇ Timing Chart

This is when the "External Operating Signal Input" parameter setting is "ON" and the rotation direction switch is set to "FWD."

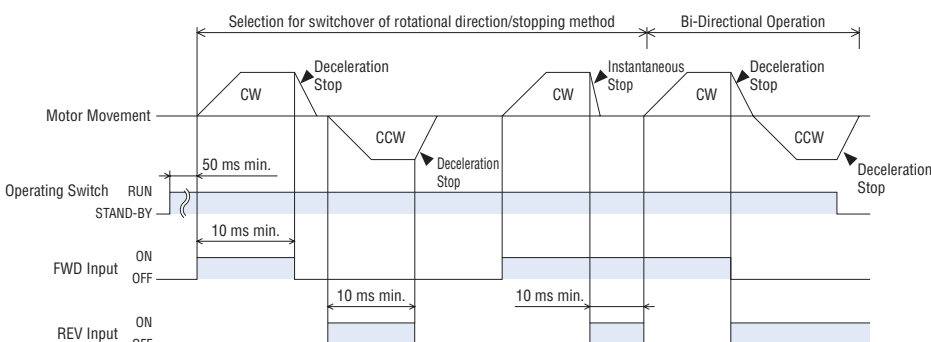

- Switching the FWD input to ON will cause the motor to rotate clockwise as viewed from the motor shaft side, while switching the REV input to ON will cause the motor to rotate counterclockwise. Turning it OFF decelerates the motor to a stop.
- If the FWD input and REV input are turned ON simultaneously, the motor will stop instantaneously.
- With the combination type, the rotation direction varies according to the gear ratio of the gearhead.

◇ I/O Signal and Programmable Controller Connection Examples

This is a connection example for operating a motor using a transistor output type programmable controller.

● Sink Logic

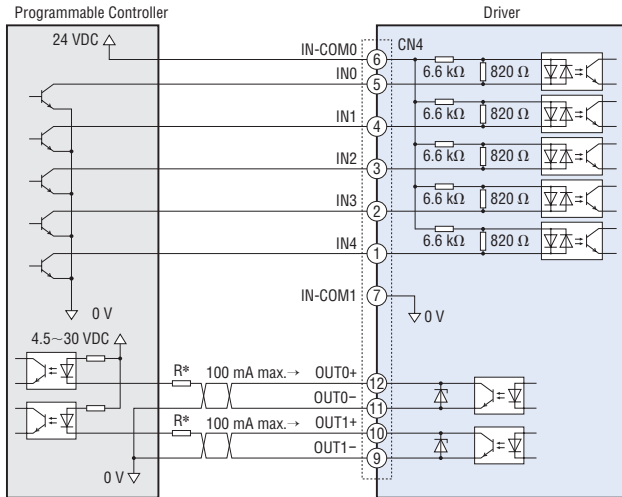

● Source Logic

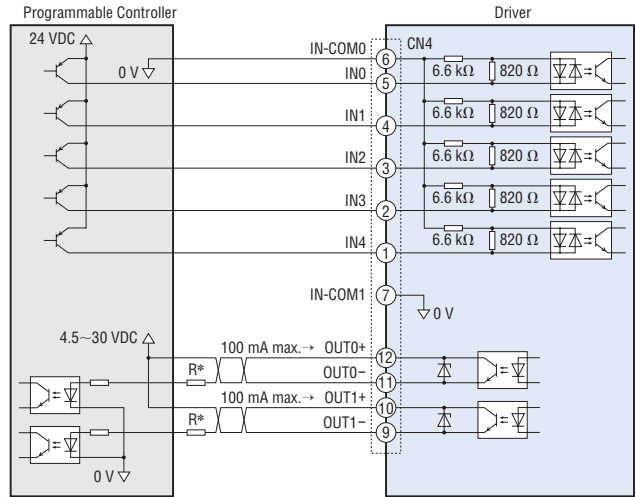

*Recommended Resistance Value
 24 VDC: 680 Ω - 2.7 kΩ (2 W)
 5 VDC: 150 Ω - 560 Ω (0.5 W)

Note

Maintain the current value of OUT0 and OUT1 at 100 mA or less. If this current value is exceeded, connect the limiting resistor R.

◇ When an External Control Device with a Built-In Clamp Diode is Used

If an external control device with a built-in clamp diode is connected and the external control device is turned off when the driver power is on, current may flow in and rotate the motor. Because the current capacity of the driver and external control device is different, the motor may also rotate when their power supplies are turned ON or OFF simultaneously. To turn the power off, turn off the driver and then the external control device. To turn the power on, turn on the external control device and then the driver.

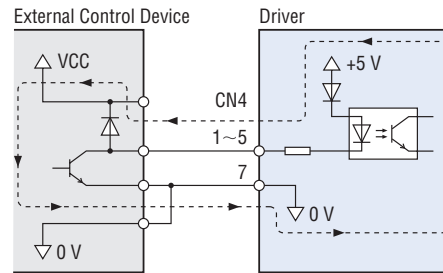

◇ When Multistep Speed-Change Operation is Used

Multistep speed-change operation is possible by switching the M0 and M1 inputs ON / OFF.

● Operating Condition Example

Operating Data No.	M0	M1	Speed [r/min]
0	OFF	OFF	3000
1	ON	OFF	1000
2	OFF	ON	2000
3	ON	ON	500

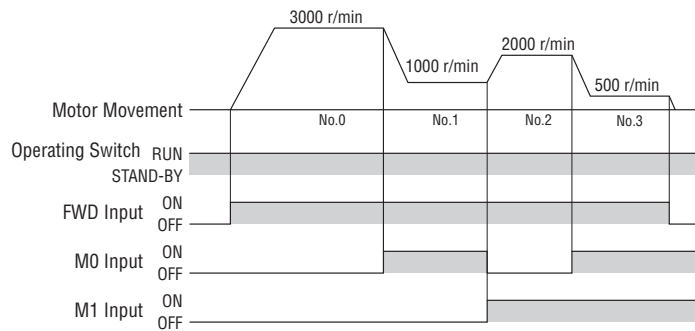

Accessories (Sold separately)

● Cable System Configuration

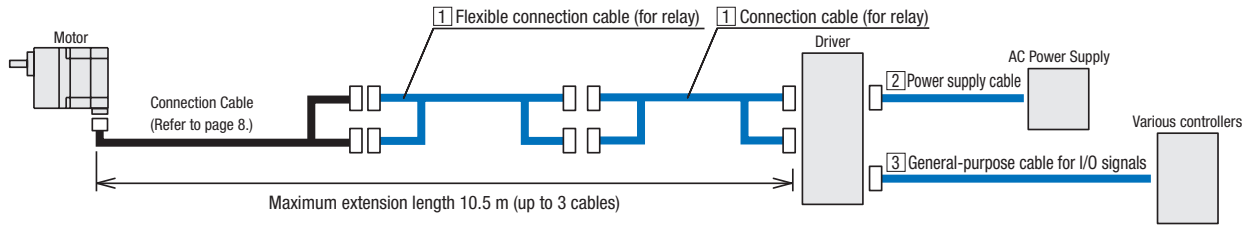

1 Connection Cables (For relay), Flexible Connection Cables (For relay)

When using a connection cable (for relay) or flexible connection cable (for relay) in tandem to extend the length, please keep the total cable length under 10.5 m (up to 3 cables total).

● Product Line

◇ Connection Cables

Product Name	Length L [m]
CC01BL2	1
CC02BL2	2
CC03BL2	3
CC05BL2	5
CC07BL2	7
CC10BL2	10



◇ Flexible Connection Cables

Product Name	Length L [m]
CC01BL2R	1
CC02BL2R	2
CC03BL2R	3
CC05BL2R	5
CC07BL2R	7
CC10BL2R	10



2 Power Supply Cables

These cables are used to connect the driver and the AC power supply. Cables are available with or without a power supply plug.



Plug Included

3 General-Purpose Cables for I/O Signals

These are cables for connecting the driver and programmable controller.



● Product Line

Product Name	Product Line	Power Supply Voltage	Length L [m]
CC01AC03N	No plug	Single-phase 100-120 VAC	1
CC02AC03N			2
CC03AC03N			3
CC01AC04N	No plug	Three-phase 200-240 VAC	1
CC02AC04N			2
CC03AC04N			3

● Product Line

Product Name	Length L [m]	Number of Lead Wire Cores	Outer diameter D [mm]	AWG
CC06D005B-1	0.5	6	φ5.4	24
CC06D010B-1	1			
CC06D015B-1	1.5			
CC06D020B-1	2	10	φ6.7	
CC10D005B-1	0.5			
CC10D010B-1	1			
CC10D015B-1	1.5			
CC10D020B-1	2			

For details, check the website or contact the customer support center.

<http://www.orientalmotor.eu>

Flexible Coupling

A clamp type coupling for connecting the motor and gearhead shaft with a driven shaft.

Couplings that can be used with combination type and round shaft type models are available.

- Couplings can also be used on the round shaft type. Please select a coupling with the same inner diameter as the motor shaft diameter.



Product Line

Product Name	Applicable Product (Motor)
MCL30 type	BLM230 combination type
MCL40 type	BLM460 combination type
MCL55 type	BLM5120 combination type
MCL65 type	BLM6200 combination type BLM6300 combination type

Mounting Bracket for Motor and Gearhead

These dedicated installation brackets are for installing motors and gearheads.



Product Line

Product Name	Applicable Product (Motor)
SOL2M4F	BLM230 BLM260 (round shaft type)
SOL4M6F	BLM460 (combination type)
SOL5M8F	BLM5120 BLM5200, BLM5300 (round shaft type)
SOL6M8F	BLM6200, BLM6300 (combination type)

Note

When fixing a mounting bracket and motor, please ensure that the motor connector is above or beside the installation surface. We do not recommend installing below the installation surface, since this causes interference with the mounting bracket and installation surface.

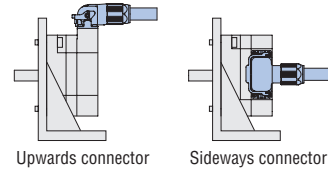

Mounting Bracket for Circuit Products

Handy installation brackets are available for installation of drivers. A variety of application-specific mounting brackets are available, including DIN rail mounting brackets, surface mounting brackets, and conveyor guide mounting brackets.

Product Line

Material: SPCC Surface Treatment: Trivalent chromate

Product Name	Application	Applicable Product (Driver)
MADP05-15	DIN rail mounting model	BMUD30 BMUD60 BMUD120
MAFP04-15	Surface mounting model	
MAFP05V MAFP05H	Conveyor guide mounting model	
MADP05-12B	DIN rail mounting model	BMUD200 BMUD300
MAFP04-12B	Surface mounting model	

Note

- A mounting bracket for circuit products and dust-resistant and watertight front cover (→ page 30) cannot be used in combination.



<usage examples>

For details, check the website or contact the customer support center.

<http://www.orientalmotor.eu>

Motor Covers

These are covers that protect the motor. They are compatible with the degree of protection IP66 specification, and can be used in wet and dusty environments.

Product Line

Motor Covers

Product Name
PCM5
PCM5-C



Replacement Gaskets

Please aim to replace the gaskets every year.

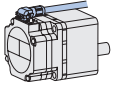

Product Name	Set Contents
PCMP5	Set of 2

Applicable Product

Output Power [W]	Motor	Cable Pull-out Direction
30, 60, 120	Parallel Shaft Combination Type*	Pull-out on output shaft side 
	Round Shaft Type	Pull-out on rear of the motor 

*In the case of a combination type, the cable with pull-out on rear of the motor cannot be used.

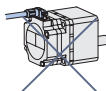

Note

The cable with vertical pull-out cannot be used.

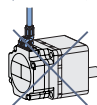

With blind gap
PCM5



With cable gland
PCM5-C

For details, check the website or contact the customer support center.

<http://www.orientalmotor.eu>

Dust-Resistant and Watertight Front Covers

These are covers that protect the driver's front panel.
They satisfy the degree of protection IP64 specification.
They can also be used to prevent erroneous operations from being performed on the front panel.

Product Line

Product Name	Applicable Product (Driver)
PCF12-B	BMUD30 BMUD60 BMUD120
PCF15-B	BMUD200 BMUD300

Note

- A dust-resistant and watertight front cover and mounting bracket for circuit products (→ page 28) cannot be used in combination.



For details, check the website or contact the customer support center.

<http://www.orientalmotor.eu>

Introduction of Related Products

Brushless Motors

BLE2 Series



The **BLE** Series has undergone a full model change. The motor, driver, and cable are all new, realizing both high function and ease of use. It is an advanced model that feels more evolved the more you use it.

●Features

- Digital setting and operation with the driver.
- External speed setting is possible.
- Torque limiting is possible.
- Multistep speed-change operation up to 16 speeds
- The motor and driver can be directly connected up to 20 m.
- Watertight and dust-resistant performance (degree of protection IP66) *Motor only
- High anti-rust and anti-corrosion properties thanks to the stainless steel shaft.
- Cables with two pull-out options for smart wiring.

Orientalmotor

These products are manufactured at plants certified with the international standards **ISO 9001** (for quality assurance) and **ISO 14001** for systems of environmental management).

Specifications are subject to change without notice. This catalogue was published in April 2024.

ORIENTAL MOTOR (EUROPA) GmbH

European Headquarters

Schiesstraße 44
40549 Düsseldorf, Germany
Tel: 0211 5206700 Fax: 0211 52067099

Spanish Office

C/Caléndula 93 - Ed. E - Miniparc III
28109 El Soto de La Moraleja,
Alcobendas (Madrid), Spain
Tel: +34 918 266 565

ORIENTAL MOTOR (UK) LTD.

UK Headquarters

Unit 5, Faraday Office Park,
Rankine Road, Basingstoke,
Hampshire RG24 8AH, U.K.
Tel: +44 1256 347090 Fax: +44 1256 347099

ORIENTAL MOTOR SWITZERLAND AG

Switzerland Headquarters

Badenerstrasse 13
5200 Brugg AG, Switzerland
Tel: +41 56 560 50 45 Fax: +41 56 560 50 47

ORIENTAL MOTOR ITALIA s.r.l.

Italy Headquarters

Via XXV Aprile 5
20016 Pero (MI), Italy
Tel: +39 2 93906346 Fax: +39 2 93906348

ORIENTAL MOTOR (FRANCE) SARL

France Headquarters

56, Rue des Hautes Pâtures
92000 Nanterre, France
Tel: +33 1 47 86 97 50 Fax: +33 1 47 82 45 16

Customer Service Center

(Support in German & English)

00800 22 55 66 22*

Mon-Thu: 08:00 - 16:30 CET

Friday: 08:00 - 15:00 CET

*Free Call Europe

info@orientalmotor.de

WWW.ORIENTALMOTOR.EU

EN | DE | UK | IT | FR | ES