

*α*STEP

AZ Series

EtherCAT Drive Profile Compatible Driver

AZ Series drivers now include EtherCAT communications compatible with CiA 402 drive profile. For use with all Oriental Motor **AZ** Series motors and linear & rotary actuators equipped with the **AZ** Series.



AC Input



DC Input

EtherCAT®

EtherCAT Communications

The **AZ** series of motors can be easily added to an existing EtherCAT network.

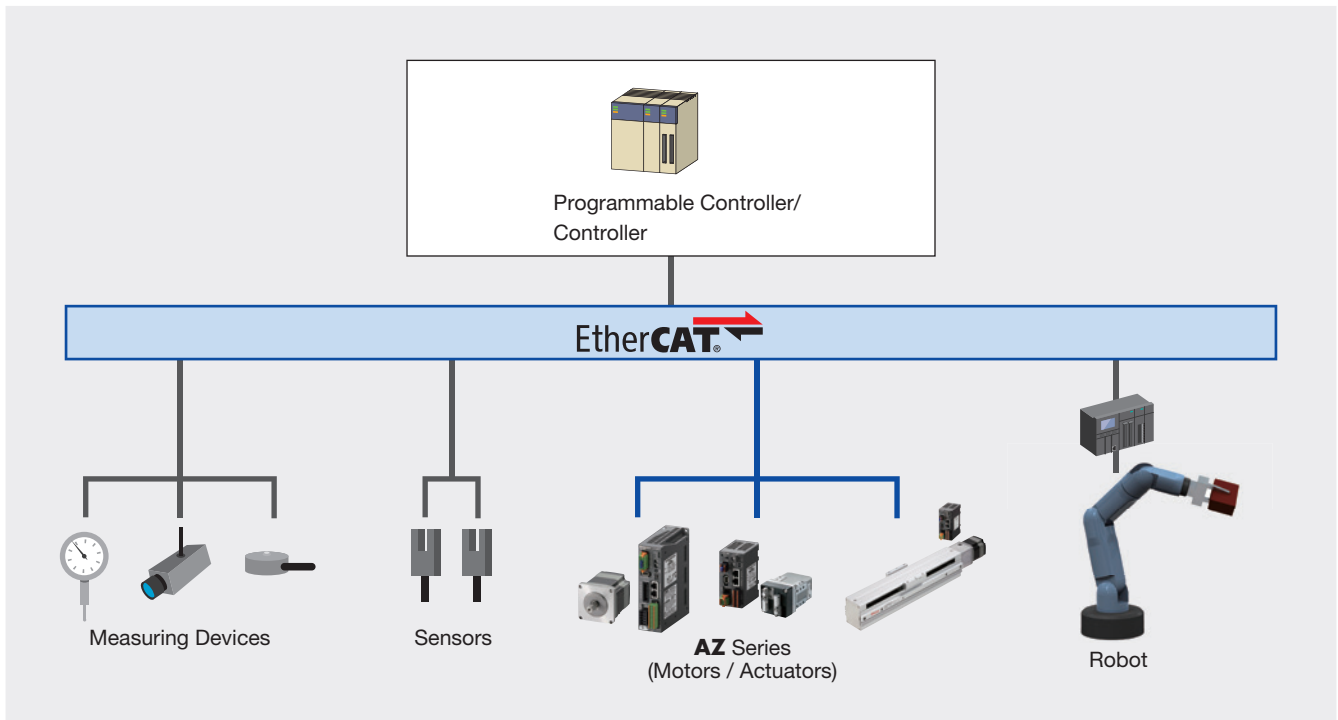

● **AZ** Series Catalog

Please see our separate catalog for the **AZ** Series products or visit our website.



AZ Series Family of Motion Control with EtherCAT

Easily control the **AZ** Series by directly connecting to the EtherCAT master device using a standard Ethernet cable. This allows for quick and simple wiring.

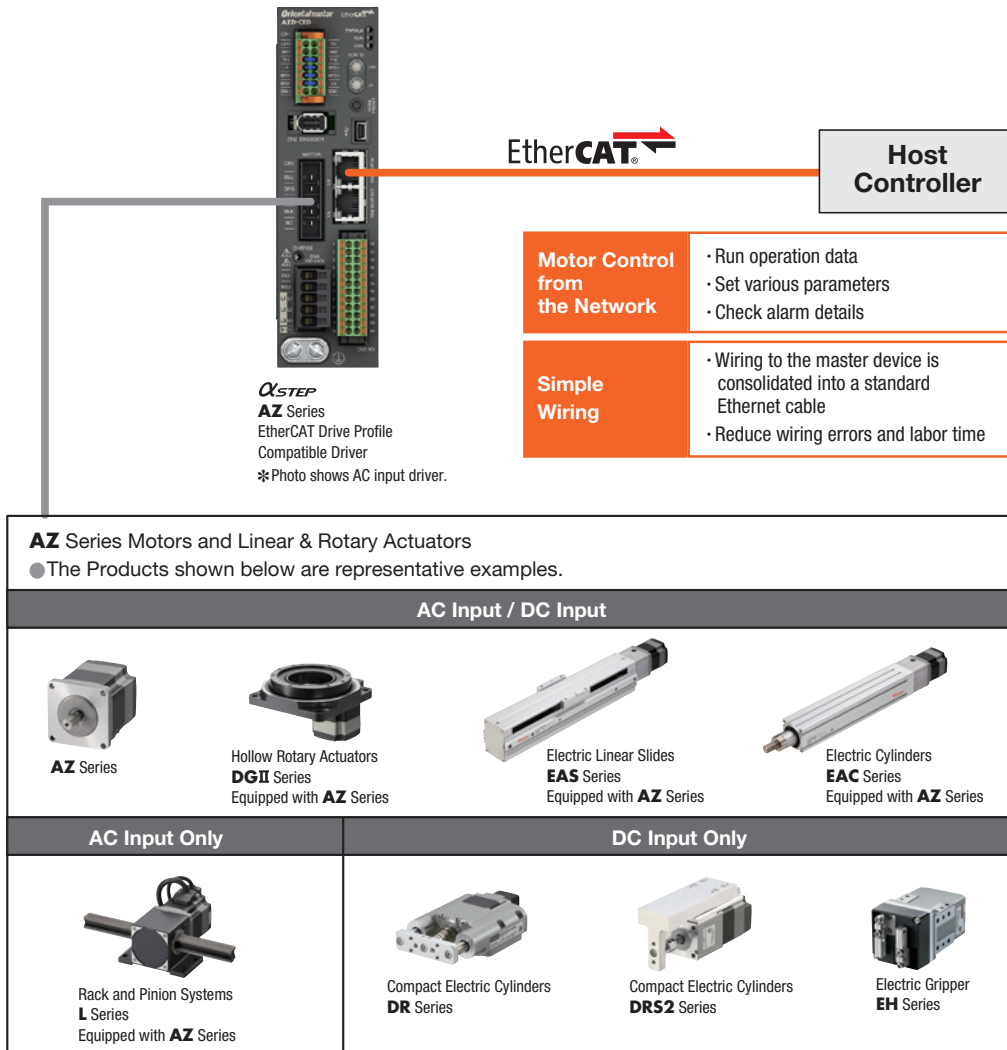

● ESI File

An ESI file has been prepared to allow EtherCAT compatible products to be used more easily. The ESI file can be downloaded from the Oriental Motor website.

AC Input

System Configuration

AZ Series with EtherCAT Drive Profile Compatible Driver

Motor, driver, and a connection cable set/flexible connection cable set are ordered separately.

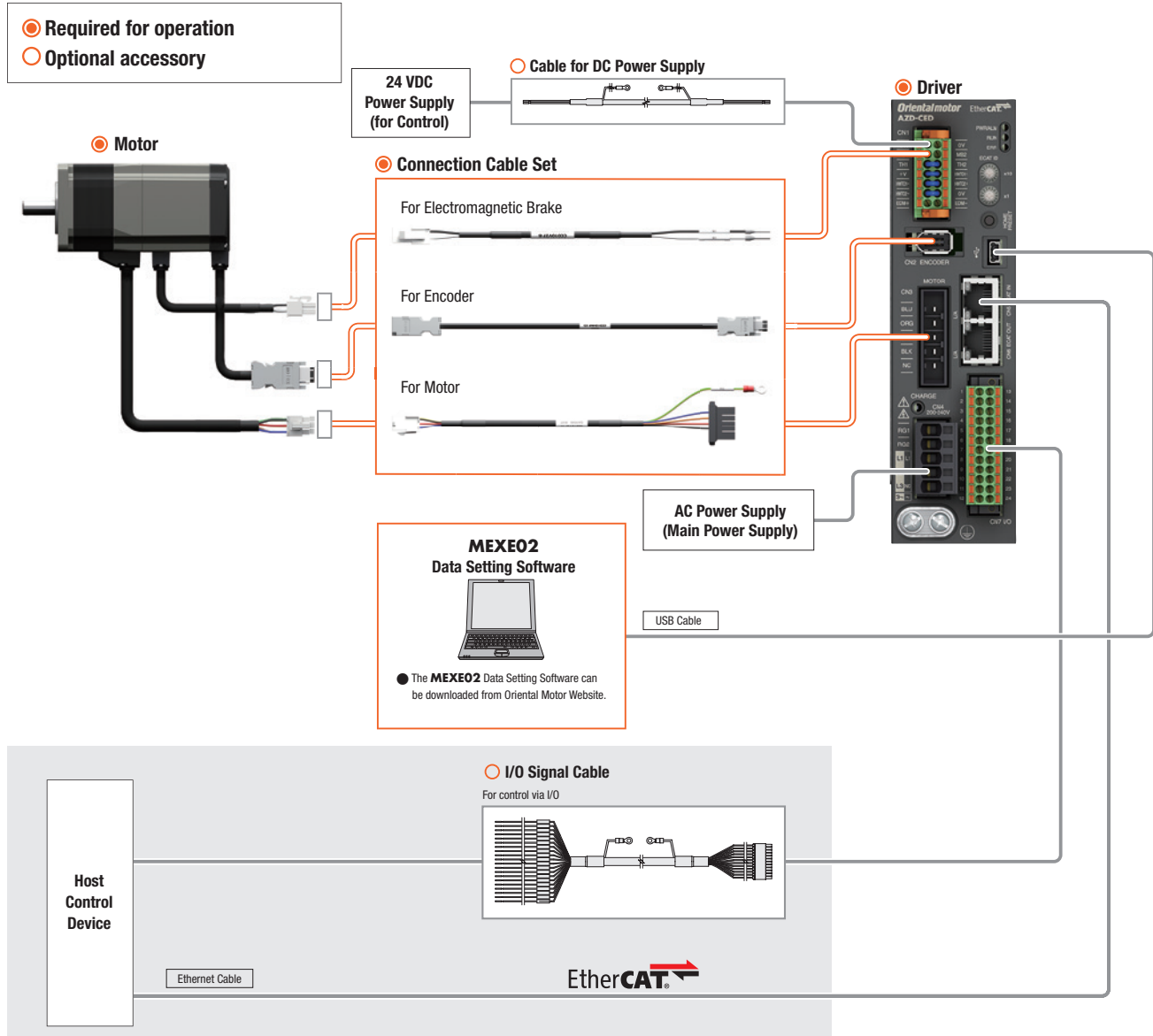

Notes

● The motor cable and electromagnetic brake cable from the motor cannot be connected directly to the driver. When connecting to the driver, use a connection cable.

Product Name

AZD - C ED

① ② ③

①	Driver Type	AZD: AZ Series Driver
②	Power Supply Input	A: Single-Phase 100-120 VAC C: Single-Phase 200-240 VAC
③	Network Type	ED: EtherCAT Drive Profile

Product Line

Power Supply Input	Product Name
Single-Phase 100-120 VAC	AZD-AED
Single-Phase 200-240 VAC	AZD-CED

Included

Connector	Operating Manual
CN4 Connector (1 pc.) CN1 Connector (1 pc.) CN7 Connector (1 pc.) Connector Wiring Lever (1 pc.)	1 Copy

Specifications

Communications Specifications

Item	Description
Communications Standards	IEC 61158 Type12
Physical Layer/Protocol	100 BASE-TX (IEEE 802.3)
Transmission Rate	100 Mbps
Communication Cycle	Free Run Mode: 1 ms or more SM2 Event Synchronization Mode: 1 ms or more DC Mode: 0.25 ms, 0.5 ms, 1 ms, 2 ms, 3 ms, 4 ms, 5 ms, 6 ms, 7 ms, 8 ms
Communication Port/Connector	RJ45×2 (Shielded) ECAT IN: EtherCAT Input ECAT OUT: EtherCAT Output
Topology	Daisy Chain (Up to 65,535 Nodes)
Process Data	Variable PDO Mapping
Sync Manager	SM0: Mailbox Output SM1: Mailbox Input SM2: Process Data Output SM3: Process Data Input
Mailbox (CoE)	Emergency Message SDO Request SDO Response SDO Information
Synchronization Mode	Free Run Mode (Asynchronous) SM2 Event Synchronization Mode DC Mode (SYNCO Event Synchronization)
Device Profile	IEC 61800-7 CIA402 Drive Profile



Driver Specifications

Driver Product Name		AZD-AED	AZD-CED
Main Power Supply	Input Voltage	Single-Phase 100-120 VAC -15 to +6% 50/60 Hz	Single-Phase 200-240 VAC -15 to +6% 50/60 Hz
	Input Current*1	AZM46: 2.7 A, AZM48: 2.7 A, AZM66: 3.8 A AZM69: 5.4 A, AZM98: 5.5 A, AZM911: 6.4 A DGB85: 2.7 A, DGM85: 2.7 A, DGM130: 3.8 A DGM200: 6.4 A LM2: 3.8 A, LM4: 3.8 A	AZM46: 1.7 A, AZM48: 1.6 A, AZM66: 2.3 A AZM69: 3.3 A, AZM98: 3.3 A, AZM911: 3.9 A DGB85: 1.7 A, DGM85: 1.7 A, DGM130: 2.3 A DGM200: 3.9 A LM2: 2.3 A, LM4: 2.3 A
Control Power Supply	Input Voltage	24 VDC $\pm 5\%$ ^{*2}	
	Input Current	0.25 A (0.5 A) ^{*3}	
Interface	Pulse Input	2 inputs, Photocoupler Maximum input pulse frequency Line Driver: 1 MHz (50% duty) Open Collector: 250 kHz (50% duty)	
	Control Input	6 inputs, Photocoupler	
	Pulse Output	2 outputs, Line driver	
	Control Output	6 outputs, Photocoupler/Open collector	
	Power Shut Down Signal Input	2 inputs, Photocoupler	
	Power Shut Down Monitor Output	1 output, Photocoupler/Open collector	
Field Network	EtherCAT		

*1 Varies according to the motor it is combined with.

*2 If an electromagnetic brake motor is used, value is 24 VDC $\pm 4\%$ when the distance between the motor and driver is extended to 20 m using an Oriental Motor cable.

*3 The value inside the () represents the value for an electromagnetic brake motor. For the **AZM46** it is 0.33 A.

General Specifications

Degree of Protection	IP10
Operating Environment	Ambient Temperature: 0 to +55°C (non-freezing) ^{*4} Humidity: 85% or less (non-condensing) Altitude: Up to 1000 m above sea level Atmosphere: No corrosive gas or dust. The product should not be exposed directly to water, oil or other liquids.
Storage Conditions Shipping Conditions	Ambient Temperature: -25 to +70°C (non-freezing) Humidity: 85% or less (non-condensing) Altitude: Up to 3000 m above sea level Atmosphere: No corrosive gas or dust. The product should not be exposed directly to water, oil or other liquids.
Insulation Resistance	When a 500 VDC megger is applied to the following locations, resistance is 100 MΩ or higher. <ul style="list-style-type: none"> Between the protective earth terminal and the main power supply terminal Between the encoder connector and the main power supply terminal Between the input signal terminal and the main power supply terminal
Dielectric Strength	No abnormalities are observed when the specified voltages are applied for 1 minute to the following locations. <ul style="list-style-type: none"> Between the protective earth terminal and the main power supply terminal 1.5 kVAC 50/60 Hz Between the encoder connector and the main power supply terminal 1.8 kVAC 50/60 Hz Between the input signal terminal and the main power supply terminal 1.8 kVAC 50/60 Hz

*4 When a heat sink is installed that is equivalent to an aluminum plate with a size of at least 200×200 mm and 2 mm of thickness

Notes

- When measuring insulation resistance or testing dielectric strength, please disconnect the motor and driver.
- Also, do not perform these tests on the absolute sensor component of the motor.

Dimensions Unit: mm

Product Name	Mass [kg]
AZD-AED, AZD-CED	0.68

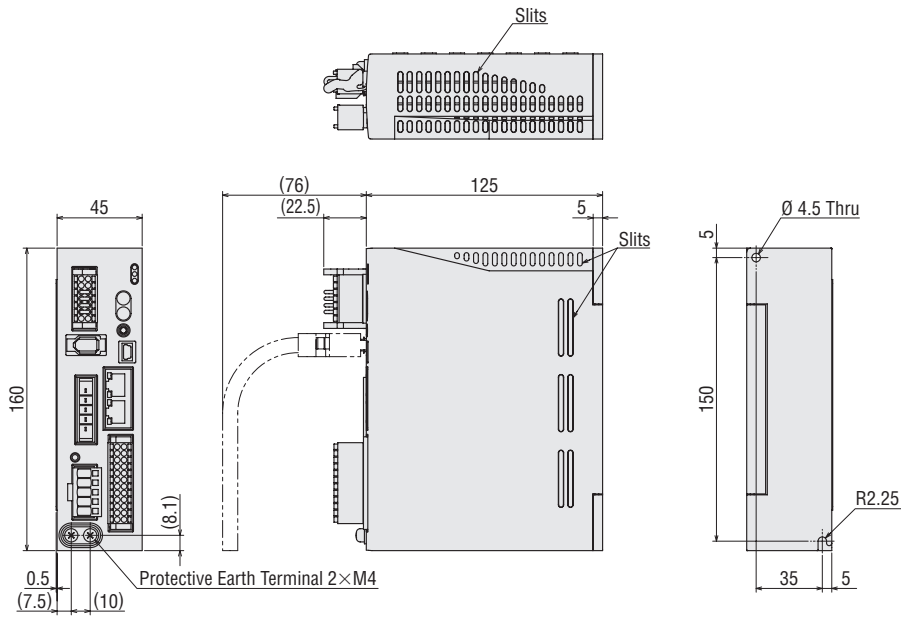

● Included

Main Power Supply/Connector for Regeneration Unit (CN4)
 Connector: 05JFAT-SAXGDK-H5.0 (J.S.T.)
 Connector Wiring Lever

24 VDC Power Supply Input/Electromagnetic Brake Connection/Regeneration Unit Thermal Input/Connector for Power Interruption Signal Input/Output (CN1)
 Connector: DFMC1,5/7-ST-3,5-LR (Phoenix Contact)

I/O Signal Connector (CN7)
 Connector: DFMC1,5/12-ST-3,5 (Phoenix Contact)

DC Input

System Configuration

AZ Series with EtherCAT Drive Profile Compatible Driver

Motor, driver, and a connection cable set/flexible connection cable set are ordered separately.

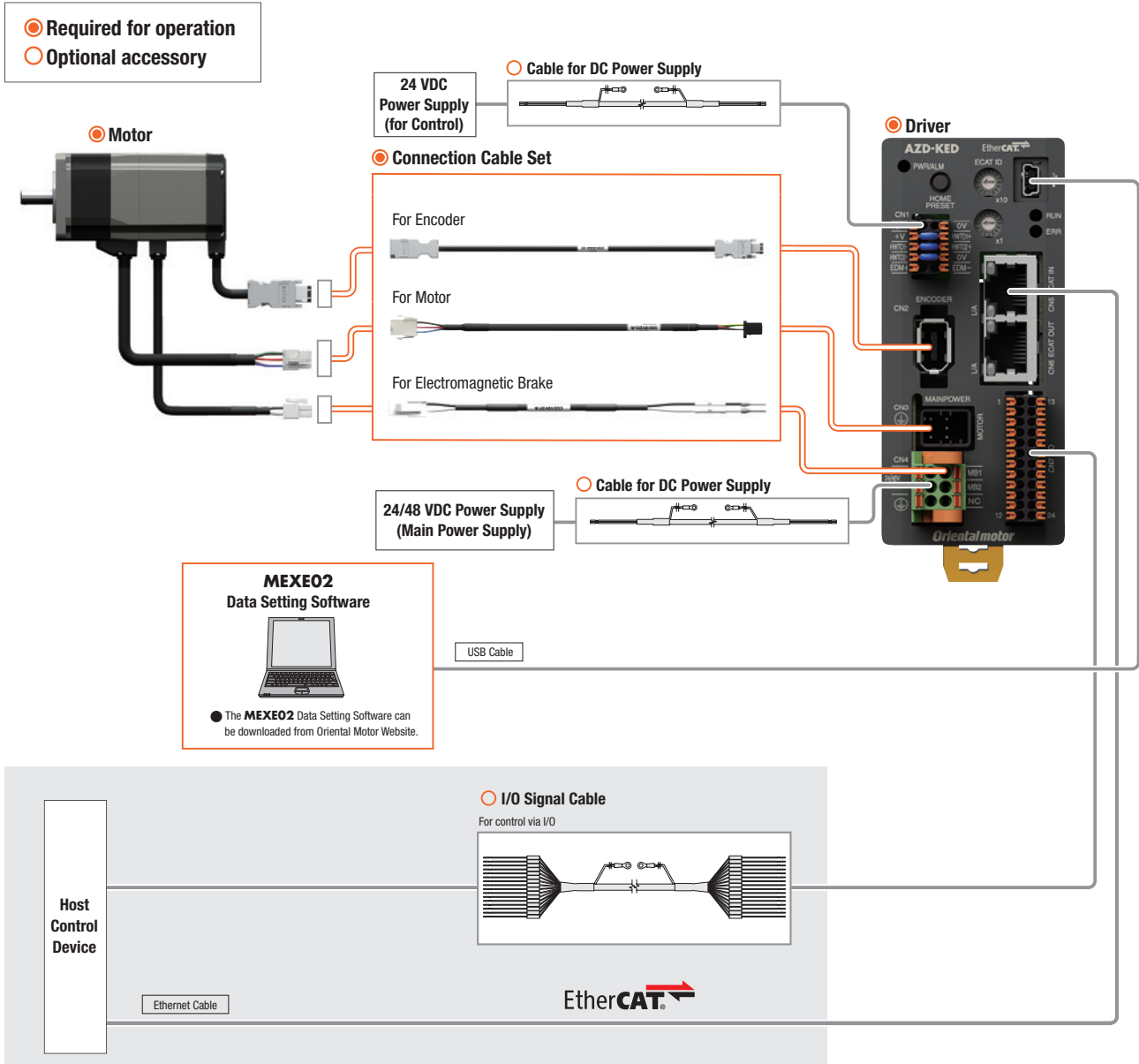

Notes

● The motor cable and electromagnetic brake cable from the motor cannot be connected directly to the driver. When connecting to a driver, use a connection cable.

Product Name

AZD - K ED

①

②

③

①	Driver Type	AZD: AZ Series Driver
②	Power Supply Input	K: 24/48 VDC
③	Network Type	ED: EtherCAT Drive Profile

Product Line

Power Supply Input	Product Name
24/48 VDC	AZD-KED

Included

Connector	Operating Manual
CN4 Connector (1 pc.) CN1 Connector (1 pc.) CN7 Connector (1 pc.)	1 Copy

Specifications

Communications Specifications

Item	Description
Communications Standards	IEC 61158 Type12
Physical Layer/Protocol	100 BASE-TX (IEEE 802.3)
Transmission Rate	100 Mbps
Communication Cycle	Free Run Mode: 1 ms or more SM2 Event Synchronization Mode: 1 ms or more DC Mode: 0.25 ms, 0.5 ms, 1 ms, 2 ms, 3 ms, 4 ms, 5 ms, 6 ms, 7 ms, 8 ms
Communication Port/Connector	RJ45×2 (Shielded) ECAT IN: EtherCAT Input ECAT OUT: EtherCAT Output
Topology	Daisy Chain (Up to 65,535 Nodes)
Process Data	Variable PDO Mapping
Sync Manager	SM0: Mailbox Output SM1: Mailbox Input SM2: Process Data Output SM3: Process Data Input
Mailbox (CoE)	Emergency Message SDO Request SDO Response SDO Information
Synchronization Mode	Free Run Mode (Asynchronous) SM2 Event Synchronization Mode DC Mode (SYNCO Event Synchronization)
Device Profile	IEC 61800-7 CIA402 Drive Profile

Driver Specifications



Driver Product Name	AZD-KED	
Main Power Supply	Input Voltage	24 VDC ±5% 48 VDC ±5%
	Input Current*1	AZM14: 0.4 A, AZM15: 0.5 A, AZM24: 1.6 A, AZM26: 1.5 A AZM46: 1.5 A, AZM48: 2.1 A, AZM66: 3.3 A, AZM69: 3.1 A DGM60: 1.6 A, DGB85: 1.5 A, DGM85: 1.5 A DGM130: 3.3 A, DR28: 1.3 A, DRSM42: 1.5 A EH4: 1.6 A
Control Power Supply	Input Voltage	24 VDC ±5%*2
	Input Current	0.15 A (0.4 A)*3
Interface	Pulse Input	2 inputs, Photocoupler Maximum input pulse frequency Line Driver: 1 MHz (50% duty) Open Collector: 250 kHz (50% duty)
	Control Input	6 inputs, Photocoupler
	Pulse Output	2 outputs, Line driver
	Control Output	6 outputs, Photocoupler/Open collector
	Power Shut Down Signal Input	2 inputs, Photocoupler
	Power Shut Down Monitor Output	1 output, Photocoupler/Open collector
	Field Network	EtherCAT

*1 Varies according to the motor it is combined with.

*2 If an electromagnetic brake motor is used, value is 24 VDC ± 4% when the distance between the motor and driver is extended to 20 m using an Oriental Motor cable.

*3 The value inside the () represents the value for an electromagnetic brake motor. For the **AZM46** it is 0.23 A.

General Specifications

Degree of Protection	IP10
Operating Environment	Ambient Temperature: 0 to +50°C (non-freezing) Humidity: 85% or less (non-condensing) Altitude: Up to 1000 m above sea level Atmosphere: No corrosive gas or dust. The product should not be exposed directly to water, oil or other liquids.
Storage Conditions Shipping Conditions	Ambient Temperature: -25 to +70°C (non-freezing) Humidity: 85% or less (non-condensing) Altitude: Up to 3000 m above sea level Atmosphere: No corrosive gas or dust. The product should not be exposed directly to water, oil or other liquids.
Insulation Resistance	When a 500 VDC megger is applied to the following locations, resistance is 100 MΩ or higher. - Between the protective earth terminal and the main power supply terminal

Notes

- When measuring insulation resistance or testing dielectric strength, please disconnect the motor and driver.
- Also, do not perform these tests on the absolute sensor component of the motor.

Dimensions Unit: mm

Product Name	Mass [kg]
AZD-KED	0.18

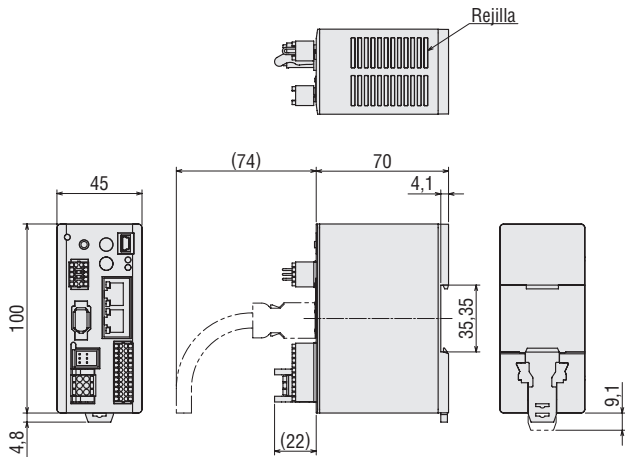

Included

Main Power Supply Connector (CN4)

Connector: DFMC1,5/3-ST-3,5-LR (Phoenix Contact)

Control Power Supply Connector (CN1)

Connector: DFMC0,5/5-ST-2,54 (Phoenix Contact)

I/O Signal Connector (CN7)

Connector: DFMC0,5/12-ST-2,54 (Phoenix Contact)

EtherCAT® is registered trademark and patented technology, licensed by Beckhoff Automation GmbH, Germany.

Orientalmotor

These products are manufactured at plants certified with the international standards **ISO 9001** (for quality assurance) and **ISO 14001** for systems of environmental management).

Specifications are subject to change without notice. This catalogue was published in January 2024.

ORIENTAL MOTOR (EUROPA) GmbH

European Headquarters

Schießstraße 44
40549 Düsseldorf, Germany
Tel: 0211 5206700 Fax: 0211 52067099

Spanish Office

C/Caléndula 93 - Ed. E - Miniparc III
28109 El Soto de La Moraleja,
Alcobendas (Madrid), Spain
Tel: +34 918 266 565

ORIENTAL MOTOR (UK) LTD.

UK Headquarters

Unit 5, Faraday Office Park,
Rankine Road, Basingstoke,
Hampshire RG24 8AH, U.K.
Tel: +44 1256 347090 Fax: +44 1256 347099

ORIENTAL MOTOR SWITZERLAND AG

Switzerland Headquarters

Badenerstrasse 13
5200 Brugg AG, Switzerland
Tel: +41 56 560 50 45 Fax: +41 56 560 50 47

ORIENTAL MOTOR ITALIA s.r.l.

Italy Headquarters

Via XXV Aprile 5
20016 Pero (MI), Italy
Tel: +39 2 93906346 Fax: +39 2 93906348

ORIENTAL MOTOR (FRANCE) SARL

France Headquarters

56, Rue des Hautes Pâtures
92000 Nanterre, France
Tel: +33 1 47 86 97 50 Fax: +33 1 47 82 45 16

Customer Service Center

(Support in German & English)

00800 22 55 66 22*

Mon - Thu: 08:00 - 16:30 CET

Friday: 08:00 - 15:00 CET

*Free Call Europe

info@orientalmotor.de

WWW.ORIENTALMOTOR.EU

EN | DE | UK | IT | FR | ES